

Type OS/80X, OS/84X and OS/88X Slam-Shut Controller

SUMMARY

Introduction	1
Characteristics.....	1
Labelling	2
Dimensions and Weight.....	2
Installation	3
Startup	3
Periodical Checks.....	3
SEP Statement	3
ATEX Requirements	3
Maintenance.....	4
Troubleshooting.....	5
Parts Lists.....	6
Schematic Assemblies.....	7

INTRODUCTION

Scope of Manual

This manual provides installation, startup, maintenance, troubleshooting, and spare parts for the slam-shut controller series OS/80X.

Product Description

Designed for pressure regulators and slam-shut valves control, the following types are available:

- **OS/80X**
Diaphragm actuator for minimum and/or maximum pressure.
Version: BP, BPA-D, MPA-D and APA-D.
- **OS/84X - OS/88X**
Piston actuator for minimum and/or maximum pressure.
- **OS/80X-PN**
Diaphragm actuator for minimum and/or maximum pressure, controlled by PRX-PN series pilots.
- **OS/84X-PN**
Piston actuator for minimum and/or maximum pressure, controlled by PRX-PN series pilots.



Figure 1. Type OS/80X-BP

Reinforced version available to be used with BM6X Series slam-shut valves, and on BM5 DN 150 slam shut valve (e.g. OS/80X-BP-R).

The full range of OS/80X slam-shut controllers can be installed in the following equipments:

BFL Series - Cronos Series - BM5 Series - BM6X Series

This product has been designed to be used with fuel gases of 1st and 2nd family according to EN 437, and with other non aggressive and non fuel gases. For any other gases, other than natural gas, please contact your local sales agent.

CHARACTERISTICS

Table 1. Technical Features

MODEL	SERVOMOTOR BODY RESISTANCE (bar)	OVERPRESSURE SET RANGE Wdo (bar)		UNDERPRESSURE SET RANGE Wdu (bar)		BODY MATERIAL
		MIN.	MAX.	MIN.	MAX.	
OS/80X-BP	5	0.03	2	0.01	0.60	Aluminium
OS/80X-BPA-D	20					
OS/80X-MPA-D	100	0.50	5	0.25	4	Steel
OS/80X-APA-D		2	10	0.30	7	
OS/84X		5	41	4	16	Brass
OS/88X		18	80	8	70	
OS/80X-PN		0.5	40	0.5	40	Steel
OS/84X-PN		30	80	30	80	Brass

1/4-inch NPT female threaded connections.

OS/80X Series

LABELLING

		APPARECCHIO TIPO / DEVICE TYPE	
MATICOLA		Note 1	
SERIAL Nr.		DN1	
ANNO		DN2	
YEAR	Note 2	Wa	Note 4 bar
NORME ARMONIZ.	EN	Wao	Note 5 bar
HARMONIZED STD.		Wau	Note 5 bar
CLASSE DI PERDITA			
LEAKAGE CLASS			
CLASSE FUNZIONALE			
FUNCTIONAL CLASS			
FLUIDO GRUPPO	1	pmax	bar
FLUID GROUP		pao	bar
TS	Note 3 °C	PS body	bar
		PS covers	- bar
		PT=	1.5 x PS bar

Figure 2. Label for OS/80X Series

Note 1: See “Characteristics”

Note 2: Year of Manufacture

Note 3: Class 1: -10° to 60°C

Class 2: -20° to 60°C

Note 4: Specific set-point according to order

Note 5: See “Characteristics”

DIMENSIONS AND WEIGHT

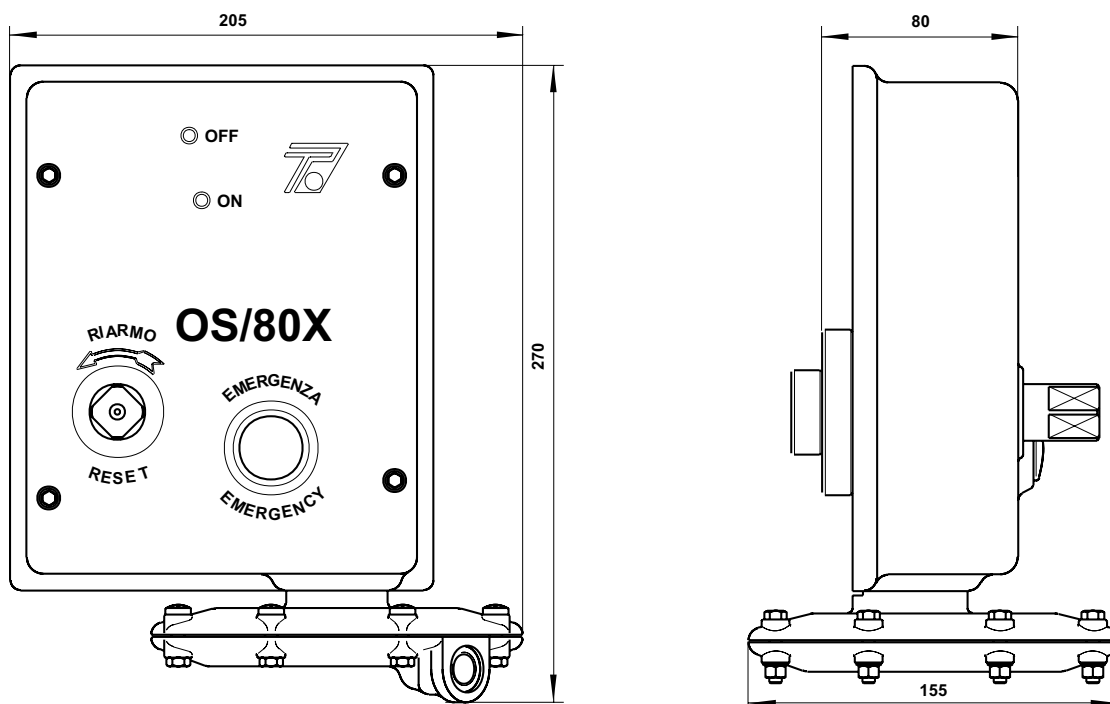

OS/08X SERIES FULL RANGE WEIGHT: UP TO 7.5 kg

Figure 3. OS/80X Series Dimensions (mm)

INSTALLATION

- Install the actuator in a covered area and protect it against weather agents.
- Check that data on the plate are compatible with actual working conditions.
- Make sure actuator is installed upright, i.e. screw (key 49) on top.



CAUTION

Mounting in any other way will jeopardize actuator's performance.

- Carry out the connection of gas outlet (A). It must be derived from the pressure control piping, in a straight tract, possibly far away from restrictions, curves or derivations, in order to avoid turbulence that can alter the trip pressure setpoints.

STARTUP

- Using lever, activate slam-shut by turning reset pin (key 6) in the direction shown by the arrow.
- Wait until the pressure being controlled stabilizes and then slowly release lever.
- Now repeat this procedure, make sure that levers keep actuator properly set and that lever (key 33) is in horizontal position.

PERIODICAL CHECKS

It is recommended that actuator be efficiency checked periodically.

Cut-off Test

- Cutoff the circuit by means of inlet and outlet valves and disconnect the pressure control pipe (A). The Actuator should cutoff at minimum pressure (only if so set).
- Through the pressure control connection, use a small pump or other appropriate means, to raise the pressure to normal operating level. Reset actuator after cutoff in step a.
- Simulate pressure increase until maximum pressure cutoff value is reached.
- Connect the pressure control actuator (A) and set the circuit back to operating conditions by following the instructions described in the Startup section.

Valve-seal Check

- Slowly close the valve located downstream.
- Press the "EMERGENCY" button. This will cause the immediate closing of slam-shut device.
- Loosen a connector in the downstream line of the slam-shut device or of the regulator. Check the connector with soap and water, making sure there are no leaks; make any necessary repairs otherwise.

SEP STATEMENT

Emerson Process declares this product conforms to Pressure Equipment Directive (PED) 97/23/EC.

Article 3 section 3 and was designed and manufactured in accordance with sound engineering practice (SEP).

Per Article 3 section 3, this "SEP" product must not bear the CE marking.

ATEX REQUIREMENTS



WARNING

If the provisions of EN 12186 & EN 12279, national regulations, if any, and specific manufacturer recommendations are not put into practice before installation and if purge by inert gas is not carried out before equipment's start-up and shut-down operations, a potential external and internal explosive atmosphere can be present in equipment & gas pressure regulating/ measuring stations/installations.

If a presence of foreign material in the pipelines is foreseen and purge by inert gas is not carried out, the following procedure is recommended to avoid any possible external ignition source inside the equipment due to mechanical generated sparks:

- drainage to safe area via drain lines of foreign materials, if any, by inflow of fuel gas with low velocity in the pipe-work (5m/sec)

In any case,

- provisions of Directive 1999/92/EC and 89/655/EC shall be enforced by gas pressure regulating/measuring station/installation's end user
- with a view to preventing and providing protection against explosions, technical and/or organizational measures appropriate to the nature of the operation shall be taken (e.g.: filling/exhausting of fuel gas of internal volume of the isolated part/entire installation with vent lines to safe area - 7.5.2 of EN 12186 & 7.4 of EN 12279; monitoring of settings with further exhaust of fuel gas to safe area; connection of isolated part/entire installation to downstream pipeline; ...)
- provision in 9.3 of EN 12186 & 12279 shall be enforced by pressure regulating/measuring station/installation's end user
- external tightness test shall be carried out after each reassembly at installation site using testing pressure in accordance with national rules
- periodical check/maintenance for surveillance shall be carried out complying with national regulations, if any, and specific manufacturer recommendations.

OS/80X Series

MAINTENANCE

Routine actuator maintenance entails simply periodic checking of the diaphragm on the Type OS/80X (the piston lip seal on the Type OS/84X) and the movement of the levers, i.e. they should move freely with a minimum of friction. If necessary, lubricate pins with "Molykote 55 M".



WARNING

For a successful job it is indispensable to use qualified personnel, possibly calling on our Technical Support Representatives. Before starting maintenance, disconnect impulse connection (A) to make sure there is no gas under pressure in the pilot. When maintenance operations are finished check the tightness with suds.

Replacing Diaphragm (OS/80X Series only)

- Remove screws (key 27) and cover (key 61).
- Replace diaphragm (key 62).
- To remount diaphragm, coat it with grease, set it in place around the edge of cover (key 61) and evenly tighten screws (key 27) to ensure proper sealing.

Replacing O-ring (Type OS/84X and OS/88X only)

- Remove plug (key 61) and extract piston (key 68) from body (key 60).
- Replace O-ring (key 67) and lip seal (key 66).
- Reassemble by reversing the above procedures.

General Maintenance

- Remove screws (key 40) and casing (key 47).
- Remove dowels (key 12) and bushing (key 13).
- Slide off pin (key 6), lever assembly (key 17 and 2), balls (key 10) and shim ring (key 15). Wash parts, replace any if worn.
- Remove nuts (key 18), levers (key 20 and 36) and springs (key 37 and 21).
- Remove nut (key 30), screw (key 29) and lever (key 33).
- Remove minimum register screw (key 49), maximum register ring (key 50) and springs (key 53 and 54).
- Remove cover (key 61) on OS/80X Series, or body (key 60) on Types OS/84X and OS/88X, and proceed as directed in replacing diaphragm/O-ring section.
- Remove nut (key 70) and locknut (key 69), then slide off stem assembly (key 57).
- Loosen dowel (key 3), unscrew ring (key 9), remove ball holder (key 5) and check seals (key 4 and 8) for wear.
- Clean all parts with petrol, replace any if worn.

Reassembly

Reassemble all parts by reversing the steps in the general maintenance section. As you proceed, make sure all parts move freely without friction. If necessary, lubricate them with Molykote 55 M. Make sure to:

- Narrow the gap between nuts (key 30 and 18) so that levers (key 33, 36, and 20) have minimum play yet move freely without friction.
- Before mounting minimum spring (key 54), register position of lever (key 33) by means of nut (key 70), locking it into place with locknut (key 69).

Note

The lever (key 33) is in proper position when it is exactly horizontal and in the center of the groove of lever (key 36).

- Now remount lever assembly (key 17 and 2), balls (key 10), keeping them in their seat with grease, and stem (key 6), which is to be turned so the balls enter their seats. The stem and lever assembly should now be tightly fitted together.
- Remount bushing (key 13), make sure that the dowels are firmly set in the grooves of the stem (key 6).
- Repeatedly check if pilot resets properly and, lastly, remount minimum spring (key 54).
- Always check pilot setting.

Minimum and Maximum Setting

- Make sure that the lever (key 33) is in horizontal position when pilot is reset. If necessary, use nut and locknut (key 69 and 70) to adjust (see step b, Reassembly section).
- Use ring nut (key 50) to completely load maximum pressure spring (key 53). Loosen screw (key 49) to completely relieve minimum pressure spring (key 54).
- Disconnect pressure control pipe (A).
- Through the pressure control connection, use a small pump or other appropriate means to raise the pressure to normal operating level.
- Reset pilot and reduce the pressure until it reaches minimum cutoff level.
- Use register (key 49) to load spring (key 54) slowly until pilot is triggered.
- Repeat procedures (d) and (e) above, making any necessary adjustment in the setting.
- Bring pressure back to normal values.
- Reset pilot and raise the pressure until it reaches maximum cutoff level.

- k. Using ring nut (key 50), slowly unload spring (key 53) until cut-off point is reached.
- l. Repeat procedures (h) and (i) above, making any adjustment necessary in the setting.

Note

Whenever minimum or maximum pressure setting is not required, omit corresponding steps.

TROUBLESHOOTING

Table 2. Troubleshooting for OS/80X Series Actuator

SYMPTOMS	CAUSE	ACTIONS
Actuator does not remain set	The actuator impulse intake (A) is not connected properly	Check connections (A)
	Downstream pressure coincides with the maximum or minimum slam-shut settings	Check slam-shut settings
	Diaphragm (62) is damaged (Lip seal (66) on types OS/84X, OS/88X)	To be replaced

OS/80X Series

PARTS LISTS

Type OS/80X Series Slam-Shut Controller (See Figure 4)

Item	Description	Item	Description
1	Plate	39	Locking pin
2	Releasing bushing	40	Screw
3	Screw	41	Indicator pin
4*	Gasket	42	On-Off indicator
5	Balls holder	43	Button
6	Stem	44*	O-ring
7	Roller	45	Spring
8*	O-ring	46	Gasket
9	Reloading nut	47	Casing
10	Ball - Roller	48	Screw
11	Roller	49	Minimum pressure adjusting screw
12	Screw	50	Maximum pressure adjusting nut
13	Reloading bushing	51	Pipe assembly
14*	O-ring	52	Washer
15	Ring	53	Spring
17	Reloading lever unit	54	Spring
18	Self-locking nut	55	Lower spring holder unit
19	Washer	56	Elastic ring
20	Return lever	57	Stem unit
21	Spring	58	Spring
22	Fulcrum	59	Plate holding stem unit
24	Label	60	Top cover
26	Nut	61	Lower cover
27	Screw	62*	Diaphragm
28	Reloading pin	63	Screw
29	Screw	64	Block
30	Self-locking nut	65*	O-ring
31	Washer	66*	Lip seal
32	Plate fulcrum	67*	O-ring
33	Lever	68	Piston
34	Screw	69	Nut
35	Cone	70	Locknut
36	Releasing lever	71	Microswitch
37	Spring	73*	Gasket (only for BP, BPA-D, MPA-D)
38	Plug	74	Filter

Rubber parts marked with (*) are supplied in the "spare parts kit", recommended as stock.

To order the kit it is necessary to communicate to us the type of the slam-shut controller and its serial number.

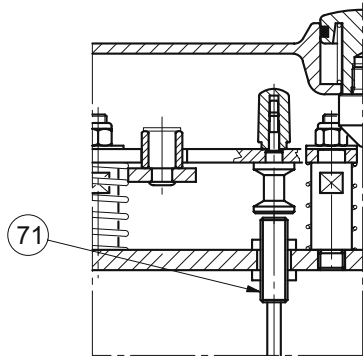

DETAIL OF TYPE OS/80X WITH MICROSWITCH

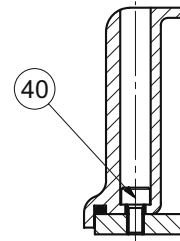

SECTION D-D

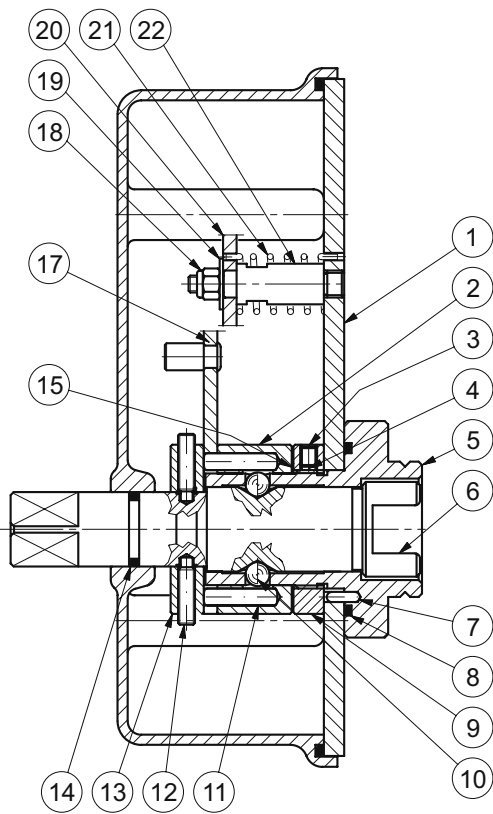

SECTION C-C

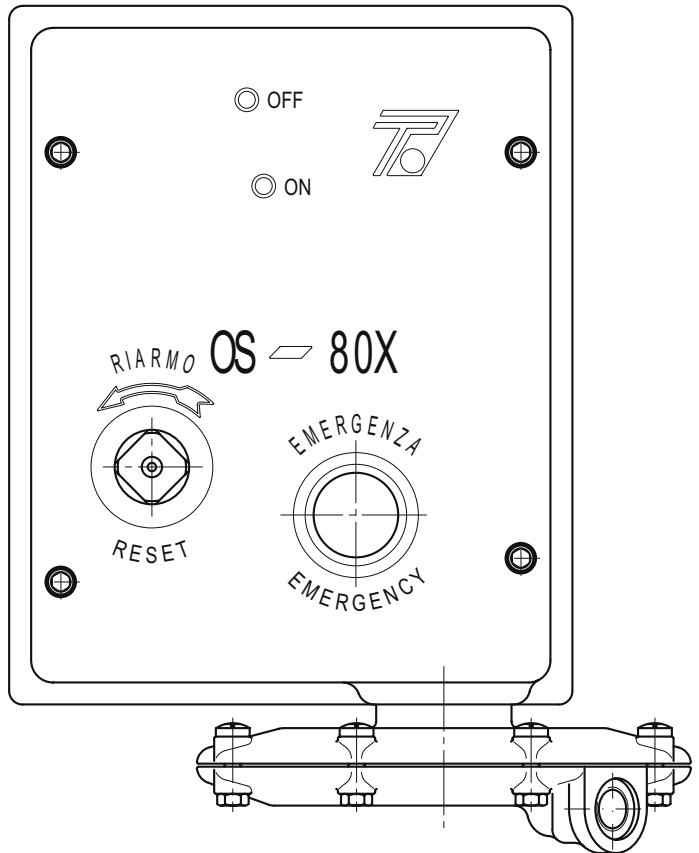

LM/1389

Figure 4. OS/80X Series Slam-Shut Controller Detailed Assembly (Standard Version)

OS/80X Series

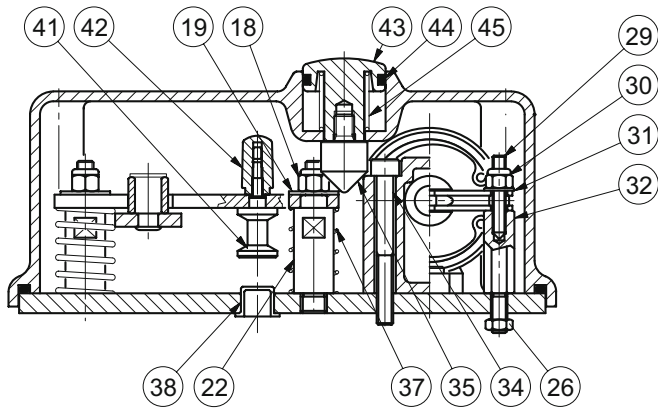

SECTION A-A

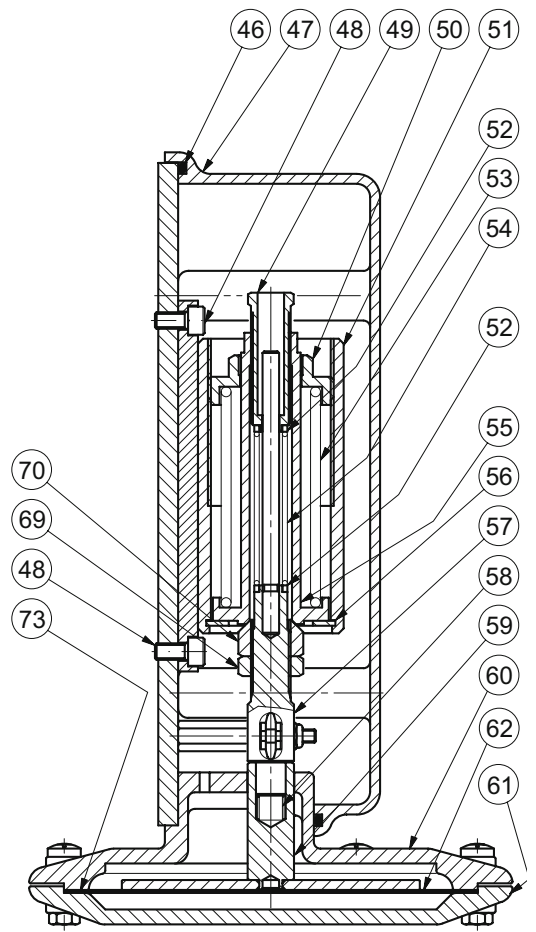
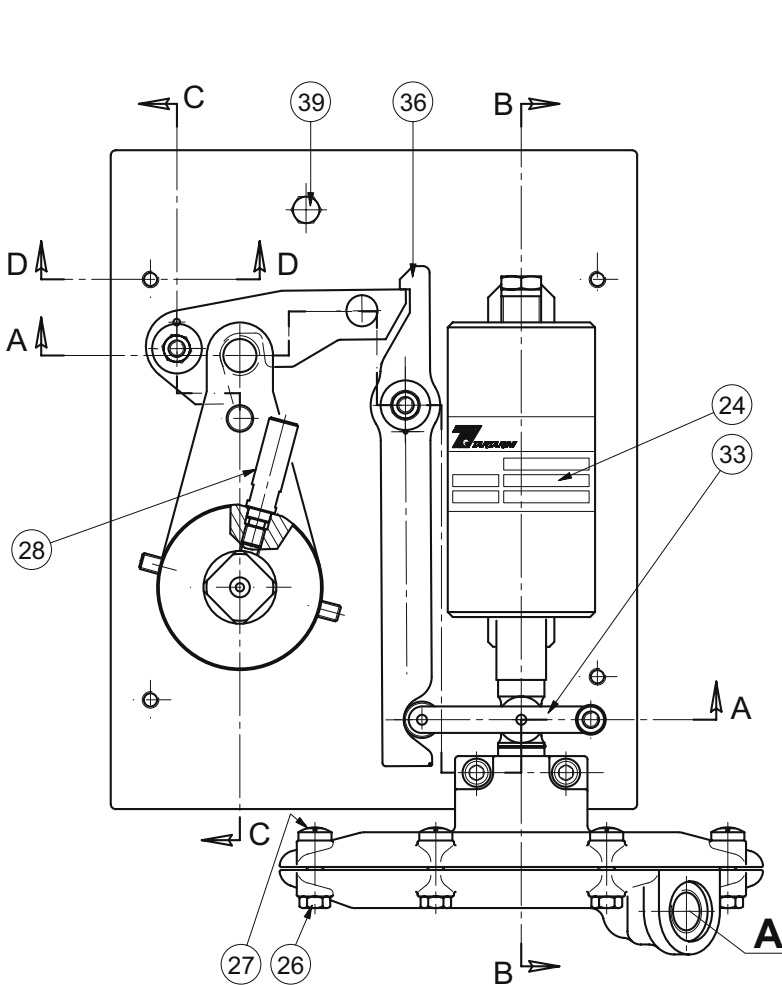

SECTION B-B

LM/1389

Figure 4. OS/80X Series Slam-Shut Controller Detailed Assembly (Standard Version) (continued)

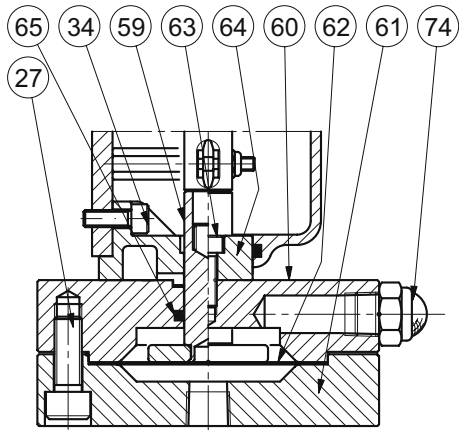

TYPE OS/80X-APA-D DETAIL

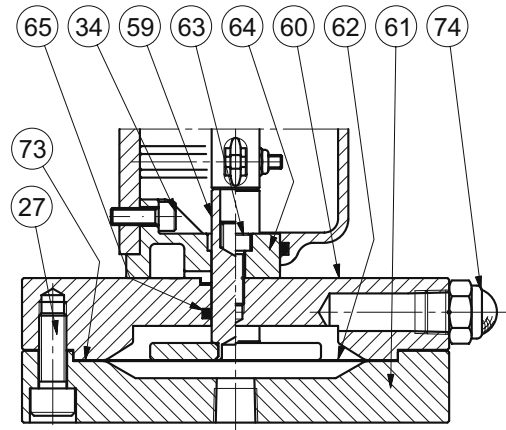

TYPE OS/80X-MPA-D DETAIL

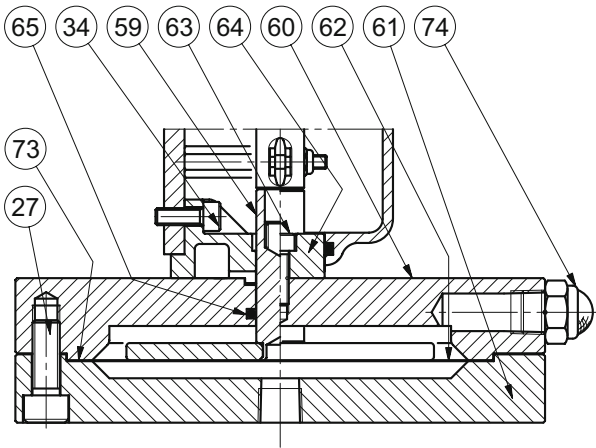

TYPE OS/80X-BPA-D DETAIL

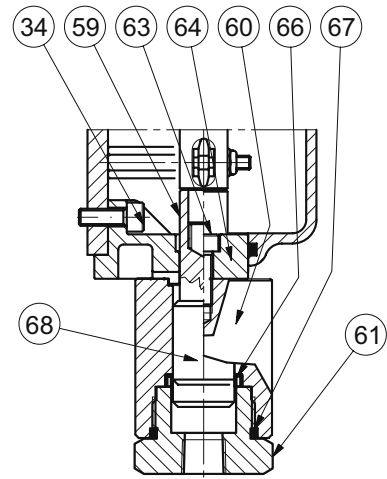

TYPE OS/84X DETAIL

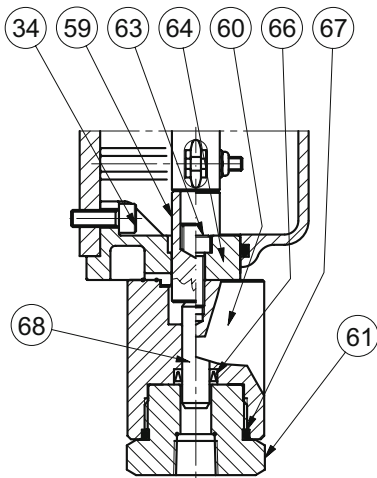

TYPE OS/88X DETAIL

LM/1389

Figure 4. OS/80X Series Slam-Shut Controller Detailed Assembly (Standard Version) (continued)

OS/80X Series

Industrial Regulators

Emerson Process Management Regulator Technologies, Inc.

USA - Headquarters
McKinney, Texas 75070, USA
Tel: +1 800 558 5853
Outside U.S. +1 972 548 3574

Asia-Pacific
Shanghai 201206, China
Tel: +86 21 2892 9000

Europe
Bologna 40013, Italy
Tel: +39 051 419 0611

Middle East and Africa
Dubai, United Arab Emirates
Tel: +971 4811 8100

Natural Gas Technologies

Emerson Process Management Regulator Technologies, Inc.

USA - Headquarters
McKinney, Texas 75070, USA
Tel: +1 800 558 5853
Outside U.S. +1 972 548 3574

Asia-Pacific
Singapore 128461, Singapore
Tel: +65 6777 8337

Europe
O.M.T. Tartarini s.r.l. Via P. Fabbri 1,
I-40013 Castel Maggiore (Bologna), Italy
Tel: +39 051 419 0611
Francel SAS, 3 ave Victor Hugo,
CS 80125 - Chartres 28008, France
Tel: +33 2 37 33 47 00

Middle East and Africa
Dubai, United Arab Emirates
Tel: +971 4811 8100

TESCOM

Emerson Process Management Tescom Corporation

USA - Headquarters
Elk River, Minnesota 55330-2445, USA
Tels: +1 763 241 3238
+1 800 447 1250

Asia-Pacific
Shanghai 201206, China
Tel: +86 21 2892 9499

Europe
Selmsdorf 23923, Germany
Tel: +49 38823 31 287

For further information visit www.emersonprocess.com/regulators

The Emerson logo is a trademark and service mark of Emerson Electric Co. All other marks are the property of their prospective owners. Tartarini is a mark of O.M.T. Officina Meccanica Tartarini s.r.l., a business of Emerson Process Management.

The contents of this publication are presented for informational purposes only, and while every effort has been made to ensure their accuracy, they are not to be construed as warranties or guarantees, express or implied, regarding the products or services described herein or their use or applicability. We reserve the right to modify or improve the designs or specifications of such products at any time without notice.

Emerson Process Management Regulator Technologies, Inc., does not assume responsibility for the selection, use or maintenance of any product. Responsibility for proper selection, use and maintenance of any Emerson Process Management Regulator Technologies, Inc., product remains solely with the purchaser.

O.M.T. Officina Meccanica Tartarini S.R.L., R.E.A 184221 BO Cod. Fisc. 00623720372 Part. IVA 00519501209 N° IVA CEE IT 00519501209,
Cap. Soc. 1.548 000 Euro i.v. R.I. 00623720372 - M BO 020330

Francel SAS, SIRET 552 068 637 00057 APE 2651B, N° TVA : FR84552068637, RCS Chartres B 552 068 637, SAS capital 534 400 Euro