

# Fisher™ D3 Control Valve with Gen 2 easy-Drive™ Electric Actuator

## Contents

Introduction .....	1
Scope of Manual .....	1
Description .....	3
Specifications .....	3
Educational Services .....	3
Installation .....	3
Special Instructions for “Safe Use” and Installations in Hazardous Locations .....	4
Startup Overview .....	5
Default Input Signals .....	10
Configuration .....	10
Input Configuration .....	10
Changing the Inputs from Default Settings ..	10
Modbus Setup .....	10
Connecting using the Fisher easy-Drive configuration software .....	11
Initial Setup .....	11
Calibration Instructions .....	12
Licensing .....	15
Startup .....	17
Troubleshooting .....	18
Setting the Valve Flow Adjuster .....	19
Maintenance .....	20
Valve Plug and Seat Ring Maintenance .....	22
Packing Maintenance .....	24
Parts Ordering .....	26

Figure 1. Fisher D3 Control Valve with Gen 2 easy-Drive Electric Actuator



Parts Kits .....	26
Parts List .....	26
Appendix A - Modbus .....	29
Appendix B - Certificate of Conformance .....	34

## Introduction

### Scope of Manual

This instruction manual provides installation, maintenance, and parts information for the Fisher D3 control valve with Gen 2 easy-Drive electric actuator. For Gen 1 electric actuators, use Fisher D3 with easy-Drive Instruction Manual, ([D103460X012](#)). If the actuator has a RPU-100 installed refer to easy-Drive RPU-100 Instruction Manual, ([D104551X012](#)).



Do not install, operate, or maintain a D3 valve with Gen 2 easy-Drive electric actuator without being fully trained and qualified in valve, actuator, and accessory installation, operation, and maintenance. To avoid personal injury or property damage, it is important to carefully read, understand, and follow all the contents of this manual, including all safety cautions and warnings. If you have any questions about these instructions, contact your [Emerson sales office](#) before proceeding.

Table 1. Specifications

**Valve Body Sizes, End Connection Styles, and Port Diameters<sup>(1)</sup>**

VALVE SIZE, NPS	PORT DIAMETER, (INCHES)	THREADED	RAISED FACE (RF) FLANGED
		CL900	CL600
1	0.375, 0.75, 1	X	X
2	0.375, 0.75, 1	X	X

X = Available construction.

**Maximum Inlet Pressures and Temperatures<sup>(1)</sup>**

VALVE BODY SIZE	MAXIMUM INLET PRESSURE	TEMPERATURE RANGE
	bar (psig)	°C (°F)
NPS 1 NPT CL900	155 (2250)	-46 to 93 (-50 to 200)
	150 (2185)	93 to 149 (200 to 300)
NPS 2 NPT CL900	155 (2250)	-46 to 93 (-50 to 200)
	150 (2185)	93 to 149 (200 to 300)
NPS 1 RF CL600	103 (1500)	-46 to 93 (-50 to 200)
	100 (1455)	93 to 149 (200 to 300)
NPS 2 RF CL600	103 (1500)	-46 to 93 (-50 to 200)
	100 (1455)	93 to 149 (200 to 300)

**Maximum Shutoff Pressure Drops<sup>(1)</sup>**

Port Size, mm (inch)	MAXIMUM ΔP BAR (PSI) PER PORT SIZE		
	9.5 (0.375)	19.1 (0.75)	25.4 (1.00)
Flow Up	155 (2250)	105 (1518)	75 (1089)
Flow Down	155 (2250)	155 (2250)	130 (1889)

**Shutoff Classification per ANSI/FCI 70-2 and IEC 60534-4**

Class IV

**Flow Characteristic / Valve Plug Style**

Equal percentage / Micro-Form Valve Plug

**Maximum Travel**

15 mm (0.6 inch)

**Material Temperature Capabilities<sup>(1)</sup>**

Valve Body Assembly:

Standard Bonnet O-Ring: -40 to 135°C (-40 to 275°F)

Electric Actuator Assembly: -20 to 70°C

(-4 to 158°F), < 90% non-condensing humidity

**Flow Direction**

Flow up (standard), Flow down (optional)

**Available Actuator Configurations**

On/off (snap acting)

Positioning (flow or pressure control)

**Power Requirements**

11 - 30 VDC, minimum 4 amp power supply required (fuse to 5 amps)

**Maximum Current Draw**

4 amps

**Idle Current Draw**

15 mA at 24 VDC, 25 mA at 12 VDC

**Conduit Connections**

Two 3/4 NPT connections

**Stroke Length**

FloPro controlled between 10 mm (0.4 inch) and 15 mm (0.6 inch)

**Nominal Stroke Speed<sup>(2)</sup>**

3.9 mm/s (0.15 inch/s) at 24 VDC

2.2 mm/s (0.09 inch/s) at 12 VDC

**Hazardous Area Approvals**

CSA (C/US): Explosion-Proof Class I, Division 1, Groups C and D, T6, Ex db IIA T6, Class I, Zone 1, AEx db IIA T6

ATEX Flameproof - Gas:

⊕ II 2 G, Ex db IIA T6 Gb

IECEx Flameproof - Gas: Ex db IIA T6 Gb

**Enclosure Rating**

Type 4X and IP66

**Duty Cycle**

50% maximum

**Enclosure Material**

Cast aluminum alloy with powder coat paint

**Approximate Weight:**

18 - 27 kg (39 - 60 lbs), depending upon construction

1. The pressure or temperature limits in the referenced tables and any applicable ASME code limitations should not be exceeded.  
2. 10% variation can be expected, based on temperature and pressure of application.

## Description

The Fisher D3 with easy-Drive electric actuator technology (figure 1) is a globe valve with electric actuator specifically designed for upstream, low power applications. The easy-Drive operates with 12 or 24 VDC in either on/off or Positioning configurations.

The on/off configuration has 2 different states; opened or closed, which are ideal for dump or snap acting applications. The Positioning configuration extends the functionality to intermediate positions for flow and pressure control applications.

## Specifications

Table 1 lists specifications for the D3 control valve. Some of the specifications for a given control valve as it originally comes from the factory are stamped on a nameplate located on the lower actuator housing.

## Educational Services

For information on available courses for the Fisher D3 control valve with Gen 2 easy-Drive electric actuator, as well as a variety of other products, contact:

Emerson Automation Solutions  
Educational Services - Registration  
Phone: 1-641-754-3771 or 1-800-338-8158  
E-mail: [education@emerson.com](mailto:education@emerson.com)  
[emerson.com/fishervalvetraining](http://emerson.com/fishervalvetraining)

## Installation

### **⚠ WARNING**

Always wear protective gloves, clothing, and eyewear when performing any installation operations to avoid personal injury.

To avoid personal injury or property damage caused by bursting of pressure-retaining parts or by uncontrolled process fluid, be certain the service conditions do not exceed the limits shown on the valve nameplate and in table 1. Use pressure-relieving devices required by government or accepted industry codes and good engineering practices.

Check with your process or safety engineer for any additional measures that must be taken to protect against process media.

If installing into an existing application, also refer to the WARNING at the beginning of the Maintenance section in this instruction manual.

### **⚠ WARNING**

For explosion-proof applications, ensure the actuator cover is properly bolted before applying power to the actuator. Personal injury or property damage may result from fire or explosion if power is applied to the actuator with the cover removed in a hazardous area.

For explosion-proof applications, install rigid metal conduit and a conduit seal no more than 457 mm (18 inches) from the actuator. Personal injury or property damage may result from explosion if the seal is not installed.

Select wiring and/or cable glands that are rated for the environment of use (such as hazardous area, ingress protection, and temperature). Failure to use properly rated wiring and/or cable glands can result in personal injury or property damage from fire or explosion.

**Wiring connections must be in accordance with local, regional, and national codes for any given hazardous area approval. Failure to follow the local, regional, and national codes could result in personal injury or property damage from fire or explosion.**

---

## CAUTION

**When ordered, the valve configuration and construction materials were selected to meet particular pressure, temperature, pressure drop, and controlled fluid conditions. Responsibility for the safety of process media and compatibility of valve materials with process media rests solely with the purchaser and end-user. Since some body/trim material combinations are limited in their pressure drop and temperature ranges, do not apply any other conditions to the valve without first contacting your Emerson Automation Solutions sales office.**

**To avoid product damage, inspect the valve before installation for any damage or any foreign material that may have collected in the valve body. Also remove any pipe scale, welding slag, or other foreign material from the pipeline.**

---

1. Before installing the control valve assembly, inspect it for any damage and for any foreign material that may have collected in the valve body.
2. Clean out all pipelines to remove scale, welding slag, and other foreign materials.
3. The control valve assembly may be installed in any orientation, but normally the actuator is vertical above the valve. Install the valve so the flow direction arrow on the side of the valve indicates the direction of the process flow.
4. Install the valve following local and national piping codes when they apply to the application. For screwed connections, treat the external pipe threads with a good grade pipe compound. For flanged connections, use suitable gaskets between valve and pipeline flanges.
5. If continuous operation is required during inspection or maintenance, install a three-valve bypass around the control valve assembly.

## Special Instructions for “Safe Use” and Installations in Hazardous Locations

### ATEX/IECEX

#### WARNING

**To avoid static discharge from the enclosure, do not rub or clean the enclosure with solvents. To do so could result in an explosion. Clean with a mild detergent and water only.**

**The enclosure is non-conducting and may generate an ignition-capable level of electrostatic charges under certain extreme conditions. The user should ensure that the equipment is not installed in a location where it may be subjected to external conditions (such as high-pressure steam) which might cause a build-up of electrostatic charges on non-conducting surfaces. Additionally, cleaning of the equipment shall only be done with a damp cloth.**

**To avoid damage to the enclosure, when screws are fully tightened into blind holes in enclosure walls, with no washer fitted, at least one full thread shall remain free at the base of the hole.**

---

# Startup Overview

Figure 2. Flowchart

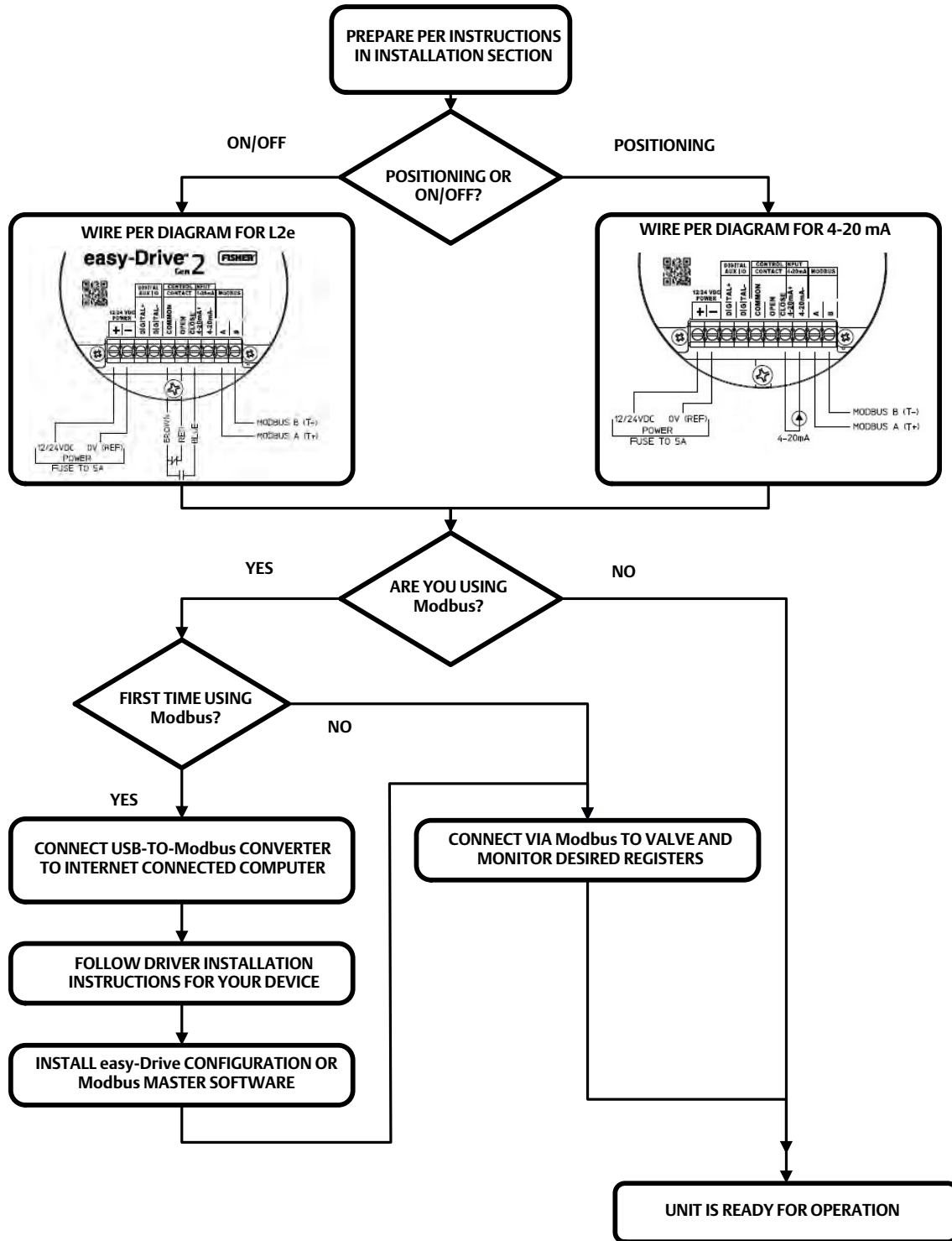
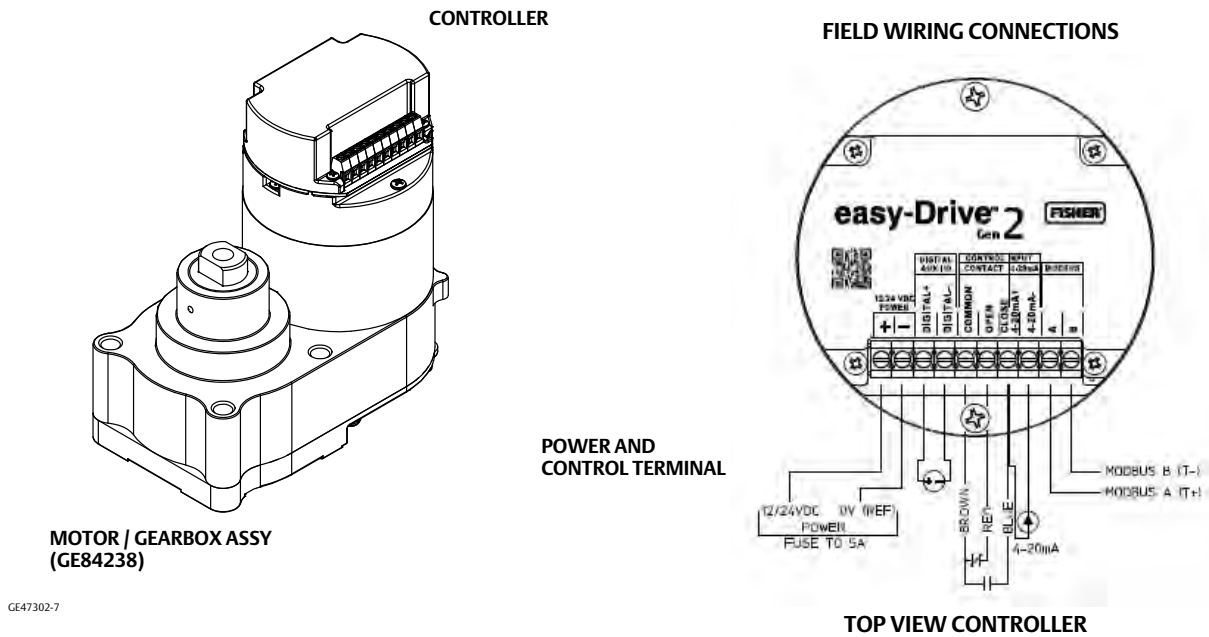

Figure 3. Fisher D3 Valve with Gen 2 easy-Drive Actuator Wiring Diagram



## Power Requirements

Ensure a stable DC power source is available, maintaining less than 5% ripple and sufficiently surge protected for the application. A 4 amp (minimum) power supply is required.

## Wiring Instructions

1. Observe local wiring requirements for hazardous location usage.
2. Conduit seals within 450 mm (18 inches) of the enclosure port are required for explosion-proof installation.
3. 18 AWG (0.52 mm<sup>2</sup>) to 12 AWG (3.31 mm<sup>2</sup>) wire size required.
4. Fuse system to 5A.
5. Connect enclosure and analog signal shields.
6. Ensure power is turned off before connecting the wires.

## Power

1. Connect 12 or 24 VDC reference to: –
2. Connect 12 or 24 VDC positive to: +
3. Be sure to tighten terminals sufficiently to ensure solid mechanical connection.

Figure 4. Wiring - Analog Input

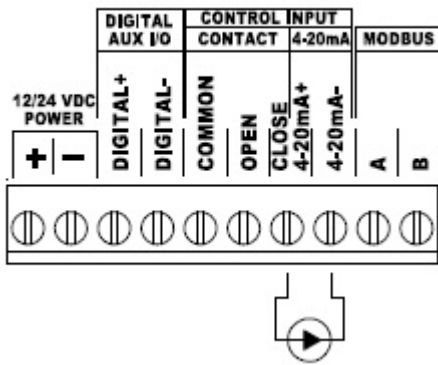

Figure 5. Wiring - L2e

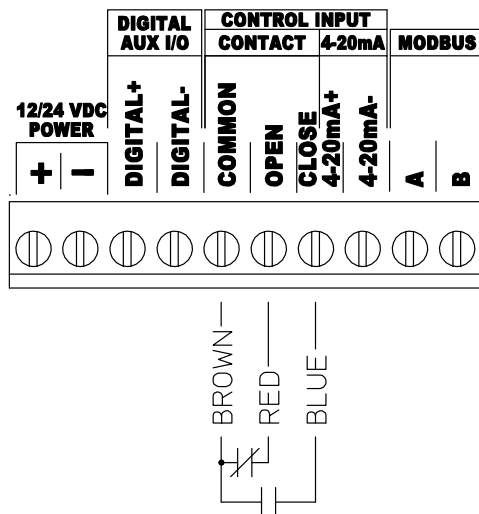

Figure 6. Wiring - Single Dry Contact

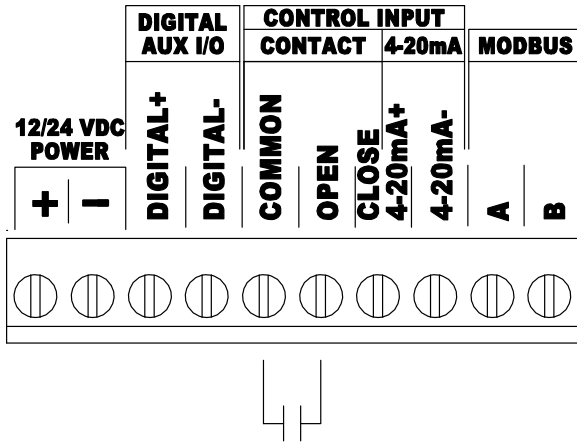

Figure 7. Wiring - Modbus Input

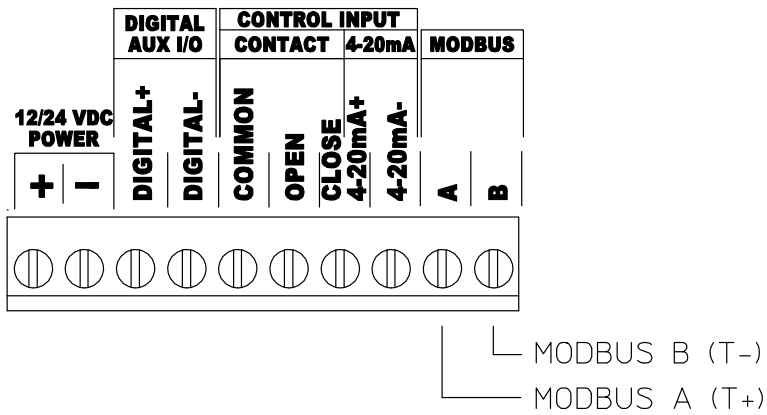



Figure 8. Wiring - Auxiliary Digital I/O set to input (40080=0)

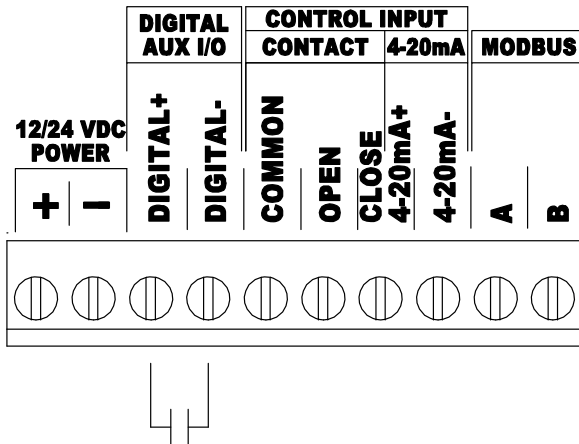
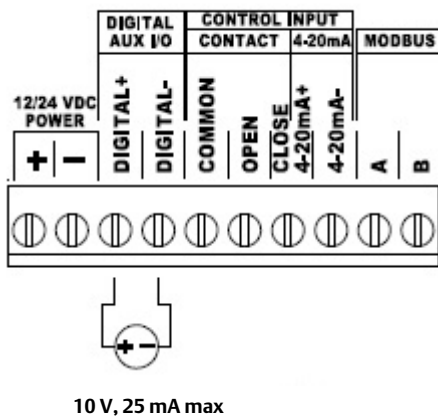

Figure 9. Wiring - Auxiliary Digital I/O set to output (40080=1)



## Default Input Signals

The D3 with easy-Drive comes from the factory calibrated and ready for use with the following default input signals shown in table 2.

Table 2. D3 easy-Drive Default Input Signals

CONFIGURATION	ON/OFF	POSITIONING
Input Signal	L2e (dual dry contact)	4-20 mA

If the input signal of the application matches table 2, proceed to the Wiring Instructions section. If the input signal of the application does not match table 2, proceed to the Configuration section.

## Configuration

### Input Configuration

There are two functional configurations available for the easy-Drive electric actuator: On/Off and Positioning. It is possible to change an actuator from On/Off to Positioning after it has been delivered from the factory using a positioning license key. See licensing section.

All available input signals are shown in table 3.

Table 3. All Available Input Signals

CONFIGURATION	ON/OFF			POSITIONING	
Control Source	Modbus	Local		Modbus	Local
Input Signal	Modbus	L2e Dual Dry Contact (default)	Single Dry Contact	Modbus	4-20 mA (default)

If you are using the default inputs signals, and the valve has not been disassembled or adjusted in any way, there is no need to recalibrate the assembly. You can proceed directly to Startup (page 17).

### Changing the Inputs from Default Settings

All configuration within the valve is done by setting values in Modbus registers. This can be done using any Modbus master (flow computer, PLC, PC). Configuration software, providing a visual interface to the registers, is available through your [Emerson sales office](#).

## Modbus setup

Use of a serial or USB to RS-485 device is required to connect to the actuator. Refer to manufacturer's requirements for installation. The D3 with easy-Drive electric actuator Modbus factory defaults are Address 1, 9600 baud, even parity, 1 stop bit, MSB.

When a connection has been achieved, the actuator may be configured to accept the input signal over the Modbus link (ignoring the physical inputs) and the Modbus settings may be changed to accommodate the network to which it is attached. Other changes to functionality are possible, such as:

- Low level cutoff: 40054 (default is 5%)
- Position upon loss of signal: 40053 (default is 0%)

See Appendix A for a full map of Modbus registers and their functions.

Figure 10. Fisher easy-Drive Configuration Software

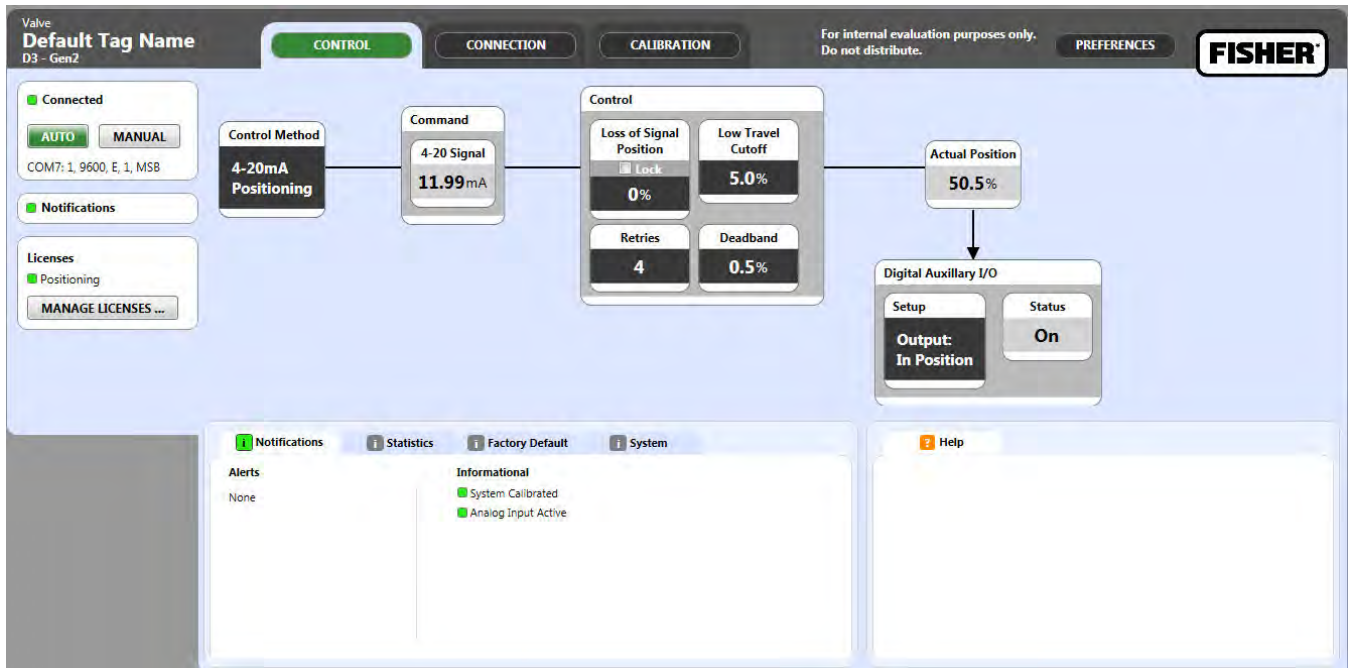

## Connecting using the Fisher easy-Drive configuration software

The Fisher easy-Drive configuration software allows configuration and diagnosing of the Fisher easy-Drive electric actuator with a graphical interface. Connect a PC to the actuator using a USB or serial device to Modbus RTU converter using the wiring instructions above. The USB or serial device will be visible in the drop menu under Serial Port Settings. Baud rate and parity should be set to the Modbus settings of the actuator. Default actuator settings are address 1, 9600 baud, even parity, 1 stop bit, MSB. Press the AUTO button in the upper left corner to connect to the valve.

Use the Fisher easy-Drive configuration software (figure 10) to make the desired changes, or register values may be changed to allow different functionality.

### Note

If an actuator is on/off, a Modbus command of 0-499 in register 40001 will cause the valve to close fully, while a value of 500-1000 will cause the valve to open fully. The command register has one implied decimal point.

## Initial Setup

The control method selection determines what control signal to which the valve will respond. Only the control signal selected will result in movement of the valve; all others will be ignored. The control methods available are dependent upon the licensing tier purchased with the valve. The functions for each tier are shown below.

- On/Off Tier

- Dual Contact On/Off
- Single Contact On/Off
- Modbus On/Off
- Positioning Tier - License required (see Licensing section)
  - Dual Contact On/Off
  - Single Contact On/Off
  - Modbus On/Off
  - Modbus Positioning
  - 4-20mA Positioning
  - 4-20mA Level

When using the easy-Drive Configuration Tool, clicking on the “Control Method” box will create a drop menu as shown. Select the desired control source; the selection will turn yellow. A box with Pending Changes will appear showing all changers. Press “APPLY” and the valve will immediately respond to that signal only.

Figure 11.

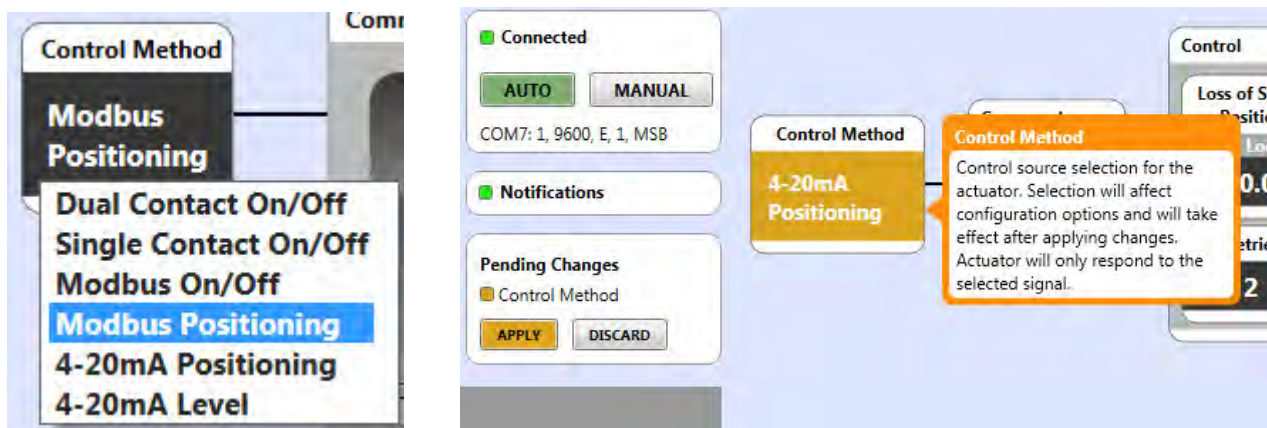

## Calibration Instructions

### **⚠ WARNING**

To avoid personal injury or property damage, be aware that the valve will open fully and then close fully during the calibration cycle.

If an easy-Drive valve has been shipped from the Fisher factory, it is not necessary to perform a span calibration. If, however, the valve has a new controller board or maintenance has been performed on the valve, such as trim replacement, it will be necessary to perform a span calibration. A span calibration is accomplished by the following method:

1. Ensure the process and valve are in a safe state – the valve may move during this operation
2. Press the CALIBRATE SPAN button to initiate the span calibration. The software will show a progress bar during the calibration and display Valve Span Calibrated when complete.

### Analog Input Calibration

For valves using 4-20 mA as a control source, several options are available to customize control of the actuator. Use a 4-20 mA signal generator to provide the desired signal. It is possible to calibrate the 4-20 mA signal in reverse acting or split-ranging with the method below with at least 4 mA of signal difference between the close and open values. The example shows a valve being changed from normal to reverse acting during the calibration process.

1. With the Control Method set to 4-20mA Positioning or 4-20mA Level, enter the Calibration screen and the 4-20mA Signal Calibration window will be visible.
2. Click the CALIBRATE CLOSE & OPEN VALUES button. A separate window will open to guide through the process.
3. Set the 4-20 mA signal to the desired value for when the valve is to be closed.
4. Enter this value into the Calibrated mA Signal text box and press Next

Figure 12.

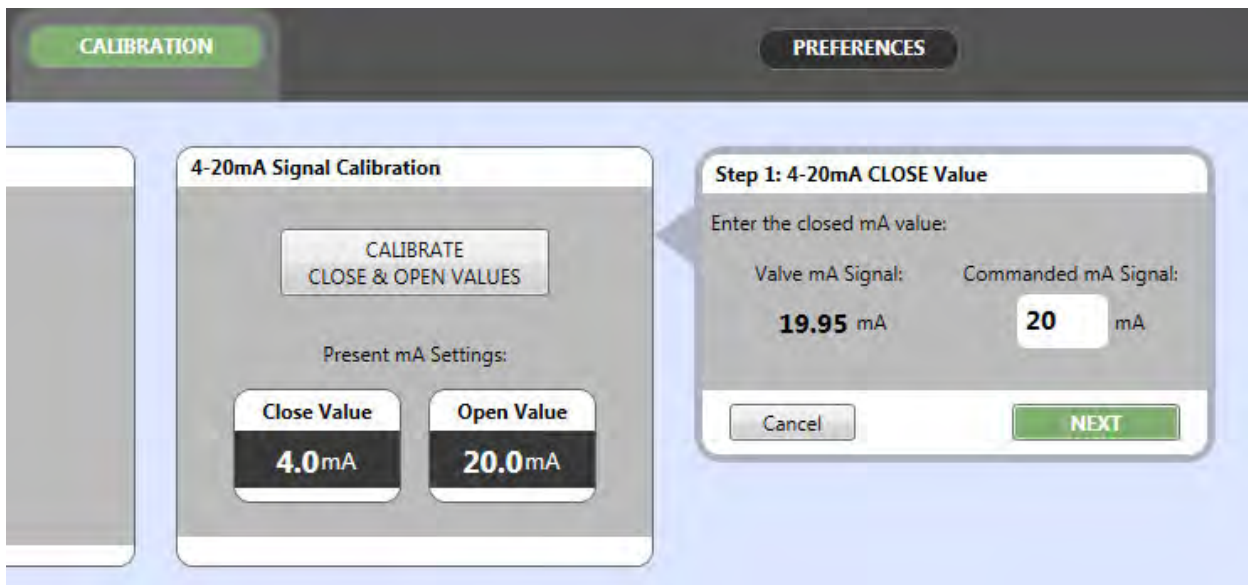

5. Set the 4-20 mA signal to the desired value for when the valve is to be open.
6. Enter this value into the Calibrated mA Signal text box and press Next

Figure 13.

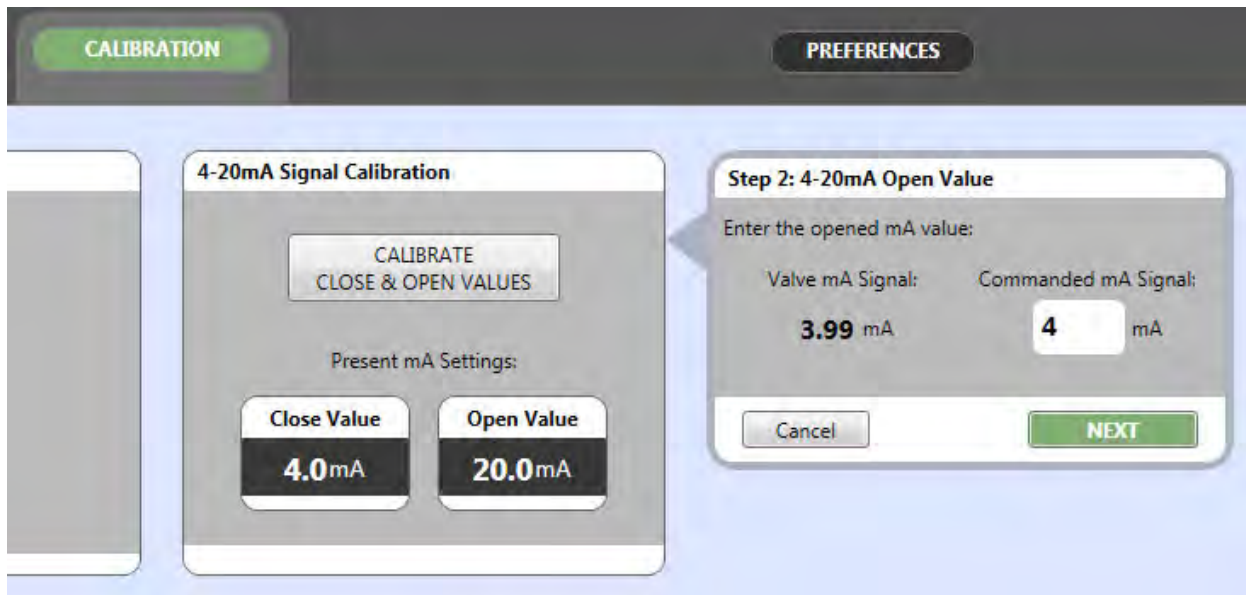

7. If the Close and Open values are as expected, press Confirm to accept these values. If not, press Cancel to restart the process.

**Note**

Note 1: The value of the 4-20 mA signal must have at least 4 mA difference between the close and open signals. A differential less than that amount will cause the actuator to reject the calibration and use the previous values.

Note 2: Should the entered values vary more than 10% from the expected 4-20 mA values; the actuator will accept the calibration and a Notification displaying “Questionable Analog Calibration” will result.

Figure 14.

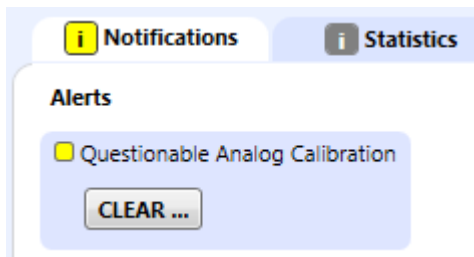

**Calibration with the use of Modbus**

1. After the unit has been properly wired and fused per instructions in the Wiring section of this instruction manual, turn power to the unit on.
2. Calibrate using Modbus:
  - a. Send position command of 0% to actuator to prevent unexpected motion. Valve will move to commanded position following the calibration procedure.

- b. Send a value of 1 to register 40043. Valve plug will move to fully open position and then to fully closed. The valve plug will then return to the commanded position.

If a Modbus connection is not available, and recalibration is desired, use the appropriate calibration method as determined by the control method of your valve.

### Calibration without the use of Modbus

1. Turn power to the actuator off.
2. Wait for 10 seconds to ensure all circuits have discharged.
3. Return power to the actuator and use the appropriate calibration method for your control signal. Calibration sequence must be done within 15 seconds of power being switched on.
4. For positioning operation using 4-20 mA:
  - a. Apply a 4 mA signal between pins 4-20 mA - and 4-20 mA +. If Span is currently uncalibrated, valve plug will not move at this time.
  - b. Apply a 20 mA signal between pins 4-20 mA - and 4-20 mA +. If Span is currently uncalibrated, valve plug will not move at this time.
  - c. Apply a 4 mA signal between pins 4-20 mA - and 4-20 mA +; valve plug will move to the upper stop, immediately followed by moving to the lower, closed position.
  - d. If calibration of the analog input is desired to improve positional accuracy, an optional operation is listed on page 13 titled Analog Input Calibration.
5. For On/Off operation using dual-input dry contact:
  - a. Close the contact to create a short between pins COMMON and CLOSE. If Span is currently uncalibrated, valve plug will not move at this time.
  - b. Close the contact to create a short between pins COMMON and OPEN. If Span is currently uncalibrated, valve plug will not move at this time.
  - c. Close the contact to create a short between pins COMMON and CLOSE; valve plug will move to the upper, open position and then to the lower, closed position.
6. For On/Off operation using single dry contact:
  - a. Open the contact to create an open circuit between pins COMMON and OPEN. If Span is currently uncalibrated, valve plug will not move at this time.
  - b. Close the contact to create a short between pins COMMON and OPEN. If Span is currently uncalibrated, valve plug will not move at this time.
  - c. Open the contact to create an open circuit between pins COMMON and OPEN; valve plug will move to the upper, open position and then to the lower, closed position.
7. The unit is now calibrated.

### Licensing

The Gen 2 easy-Drive actuator has two differing modes of operation: On/Off and Positioning. The On/Off mode is intended for snap-acting applications where the valve is either fully open or fully closed. In this mode, the valve plug cannot remain at any intermediate position; it will move to a fully closed or fully open position only. For applications that require the actuator to control over the full range of motion, it is necessary to have a Positioning license installed. A positioning license will allow access to 4-20mA positioning, 4-20mA level control and Modbus positioning.

Positioning licenses can be purchased with the actuator and installed at the factory or can be installed at a later date by use of a license key on a USB license dongle. Installation of the license can be completed using the configuration software.

1. Insert the USB license dongle into the computer connected to the Gen 2 easy-Drive actuator.

Figure 15.



2. Click the button labelled MANAGE LICENSES on the left side of the configuration software screen.

Figure 16.

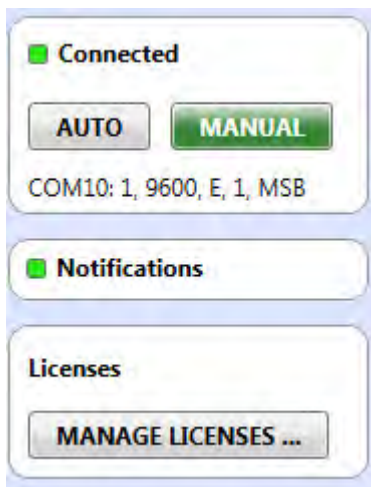

3. The license control screen will open, showing all licenses installed on the USB and the actuator.

Figure 17.

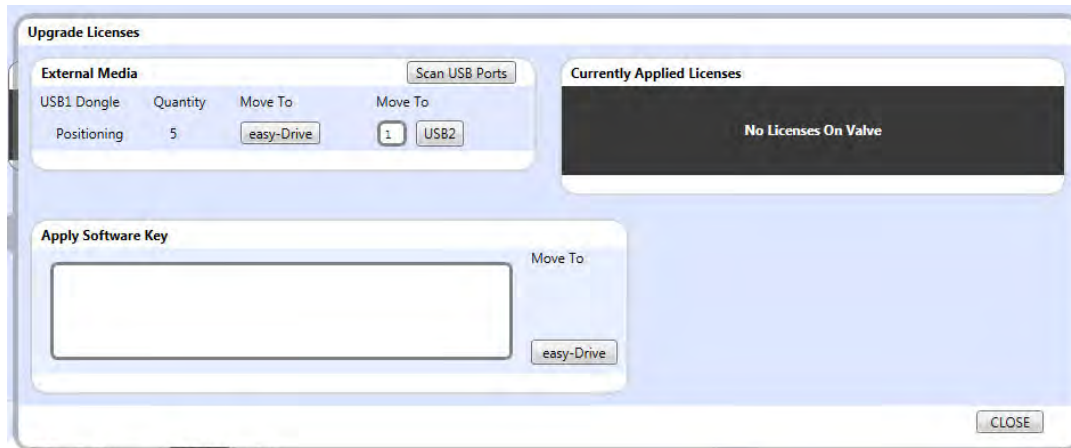



- After verifying the presence of the desired license on the USB license dongle, click the button labelled ‘easy-Drive’ under Move To, and the license will be transferred to the valve as shown below

Figure 18.

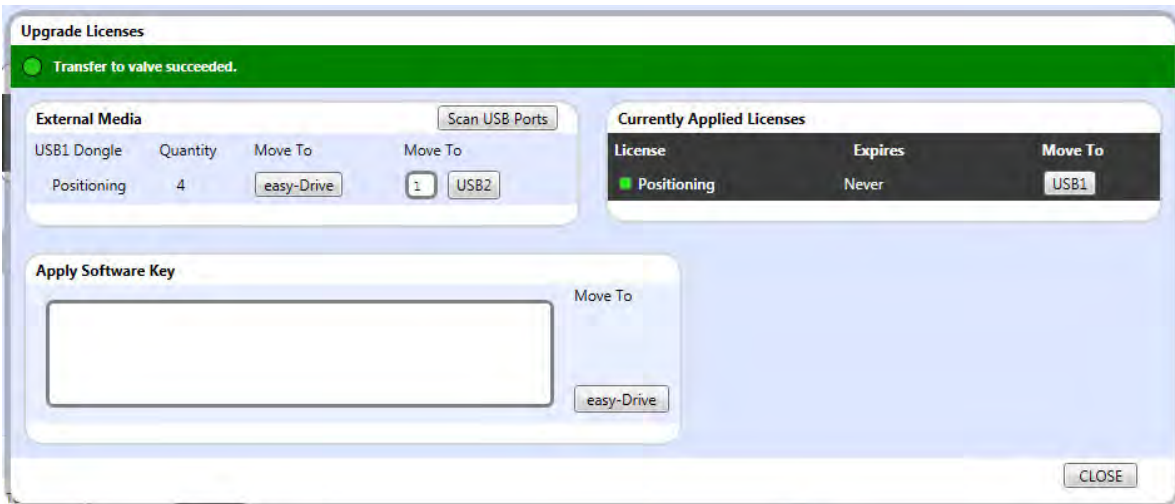

- It is also possible to transfer licenses from one USB license dongle to another. Place two dongles into the computer with the configuration software. Type in the number of licenses to move and click USB 2 to move the licenses.

## Start Up

### **⚠ WARNING**

To avoid personal injury or property damage, be aware that the valve will move and respond to an input signal during start up.

- Before turning on power to the unit, be sure that a closed signal is being commanded to the unit.
  - Dry-Contact: contact is open.
  - L2e (Dual Dry Contact): Contact closed across pins COMMON and CLOSE.
  - Analog Input: signal = 4 mA.
  - Modbus: position demand = 0.
- Turn on power to the unit.
- Apply a change in position demand to ensure unit responds properly.
  - Dry-Contact:
    - Closed contact between pins COMMON and OPEN will open the valve.
    - Dual contact / L2e only: Closed contact between pins COMMON and OPEN will open the valve. Closed contact between pins COMMON and CLOSE will close the valve.
  - Analog Input: valve will respond to proportional demand.

- Modbus: valve will respond to positional demand in register 40001. 0 = fully closed and 1000 = fully open.
4. If the valve does not respond as expected, proceed to Troubleshooting guide on page 18.
  5. Check conduit ports.
    - Conduit seal must be in place within 450 mm (18 inches) of the enclosure.
    - Unused conduit ports must be sealed with an explosion-proof port plug.
  6. Replace the cover and tighten all 8 bolts to 20 N•m (15 ft•lbs).

## Troubleshooting

1. Unit does not move.
  - a. Verify that 12VDC to 24VDC is present on the power terminals as shown on the cover. Green heartbeat LED will pulse near Modbus terminals when power is present.
  - b. Verify that all wires are firmly attached on both ends.
  - c. Verify that wires are connected to the correct terminals - see Wiring in the manual.
  - d. Verify mode of operation (on/off or positioning) matches control signal.
  - e. Verify mode of control (local or Modbus) matches control signal.
2. Unit does not respond to 4-20 mA signal
  - a. Verify that 12VDC to 24VDC is present on the power terminals as shown on the cover.
  - b. Verify that the 4-20 mA signal is wired correctly and that the terminals are firmly on the wires.
  - c. Verify mode of operation matches control signal (local control: 40067=0, positioning: 40065=1).
  - d. Check the value of the analog input in register 40026 to determine if it is 0 or greater.
    - i. If register 40026 shows 0, the 4-20 mA may be wired backwards. Swap wire and attempt again.
3. Diagnostics show a Motor Stall - Travel Deviation Fault.
  - a. The easy-Drive electric actuator is designed to operate in a manner consistent with a pneumatic actuator. This means that if the valve plug can not move to its commanded position, the actuator will stop, without damage, and issue a Motor Stall - Travel Deviation Fault warning. When the command signal changes outside of the deadband (Modbus register 40036), it will attempt to move again. Recalibrate the actuator span per instructions in the Startup section of this manual.
4. Position on D3 is not accurate (proportional positioning units only).
  - a. If the position of a D3 is too high (i.e. 50% is much higher than 50% on the bonnet), check the valve type. If valve type is D4, change to D3, cycle power, and recalibrate.
  - b. If the local analog input is being used (4-20 mA or 1-5 V), the analog inputs of the actuator may be calibrated to match the input signal.
    - i. Command 0% (4 mA or 1 V).

- ii. Using a Modbus link, send a 1 to register 40004 or use the Fisher easy-Drive configuration software by clicking the button “Analog Cal at 0%”.
- iii. Command 100% (20 mA or 5 V).
- iv. Using a Modbus link, send a 1 to register 40005 or use the Fisher easy-Drive configuration software by clicking the button “Analog Cal at 100%”.

Figure 19. Adjusts to Vary Flow Capacity (Shown with Valve Plug in Seated Position)

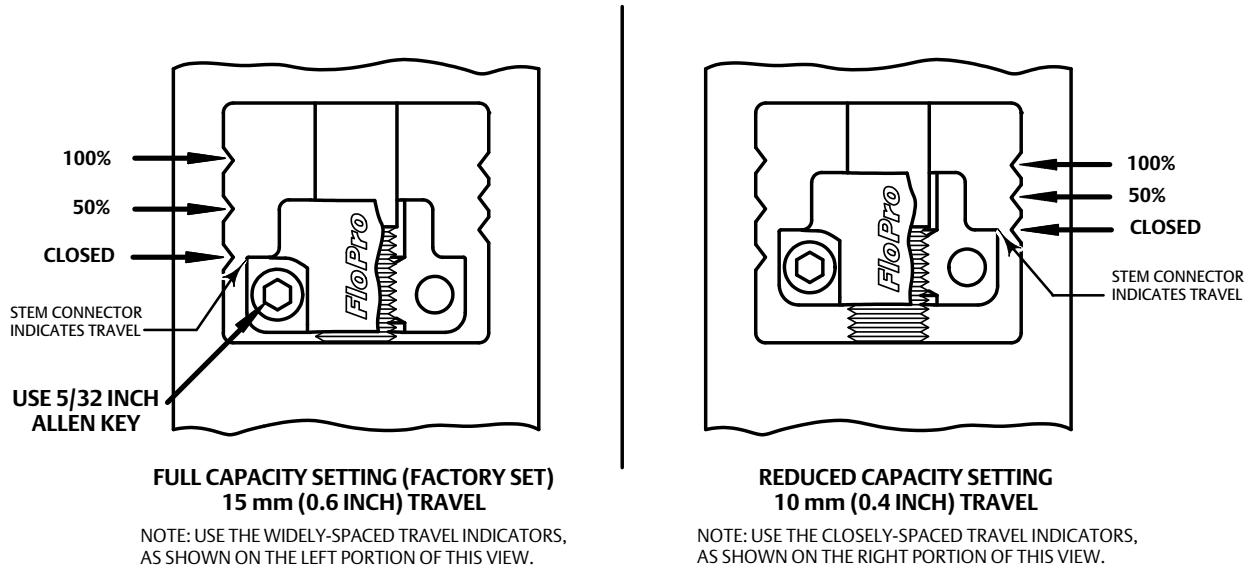

## Setting the Valve Flow Adjuster

The flow setting may only be adjusted if the 0.375 and 0.75 inch port sizes are installed and only when using the on/off version.

When shipped from the factory, the actuator has the flow adjuster set at the maximum flow rate position for the given port size.

1. Ensure the valve plug is in the seated position.
2. To change the valve flow rate, loosen the flow adjuster socket head cap screws (key 15) with a 5/32 inch Allen key, and reposition the flow adjuster halves (key 13 and 14) to the desired flow rate position. See figure 19 for flow rate settings.
3. Retighten the socket head screws (key 15) to 3 N•m (26 lbf•in).
4. Follow instructions for recalibration on page 10.

## Maintenance

Refer to figure 22.

Valve parts are subject to normal wear and must be inspected and replaced as necessary. The frequency of inspection and maintenance depends on the severity of the service conditions.

### **⚠ WARNING**

Avoid personal injury from sudden release of process pressure or bursting of parts. Before performing any maintenance operations:

- Do not remove the actuator from the valve while the valve is still pressurized.
- Always wear protective gloves, clothing, and eyewear when performing any maintenance operations to avoid personal injury.
- Disconnect any operating lines providing electric power, or a control signal to the actuator. Be sure the actuator cannot suddenly open or close the valve.
- Use bypass valves or completely shut off the process to isolate the valve from process pressure. Relieve process pressure on both sides of the valve. Drain the process media from both sides of the valve.
- Use lock-out procedures to be sure that the above measures stay in effect while you work on the equipment.
- The valve packing box may contain process fluids that are pressurized, *even when the valve has been removed from the pipeline*. Process fluids may spray out under pressure when removing the packing hardware or packing rings.
- Check with your process or safety engineer for any additional measures that must be taken to protect against process media.

### **⚠ WARNING**

For explosion-proof applications, ensure the actuator cover is properly bolted before applying power to the actuator. Personal injury or property damage may result from fire or explosion if power is applied to the actuator with the cover removed in a hazardous area.

Do not remove the actuator cover for 10 minutes after power is disconnected if the UPS option is installed.

For explosion-proof applications, install rigid metal conduit and a conduit seal no more than 457 mm (18 inches) from the transducer. Personal injury or property damage may result from explosion if the seal is not installed.

Select wiring and/or cable glands that are rated for the environment of use (such as hazardous area, ingress protection, and temperature). Failure to use properly rated wiring and/or cable glands can result in personal injury or property damage from fire or explosion.

Wiring connections must be in accordance with local, regional, and national codes for any given hazardous area approval. Failure to follow the local, regional, and national codes could result in personal injury or property damage from fire or explosion.

Figure 20. Packing and Belleville Spring Stacking Order

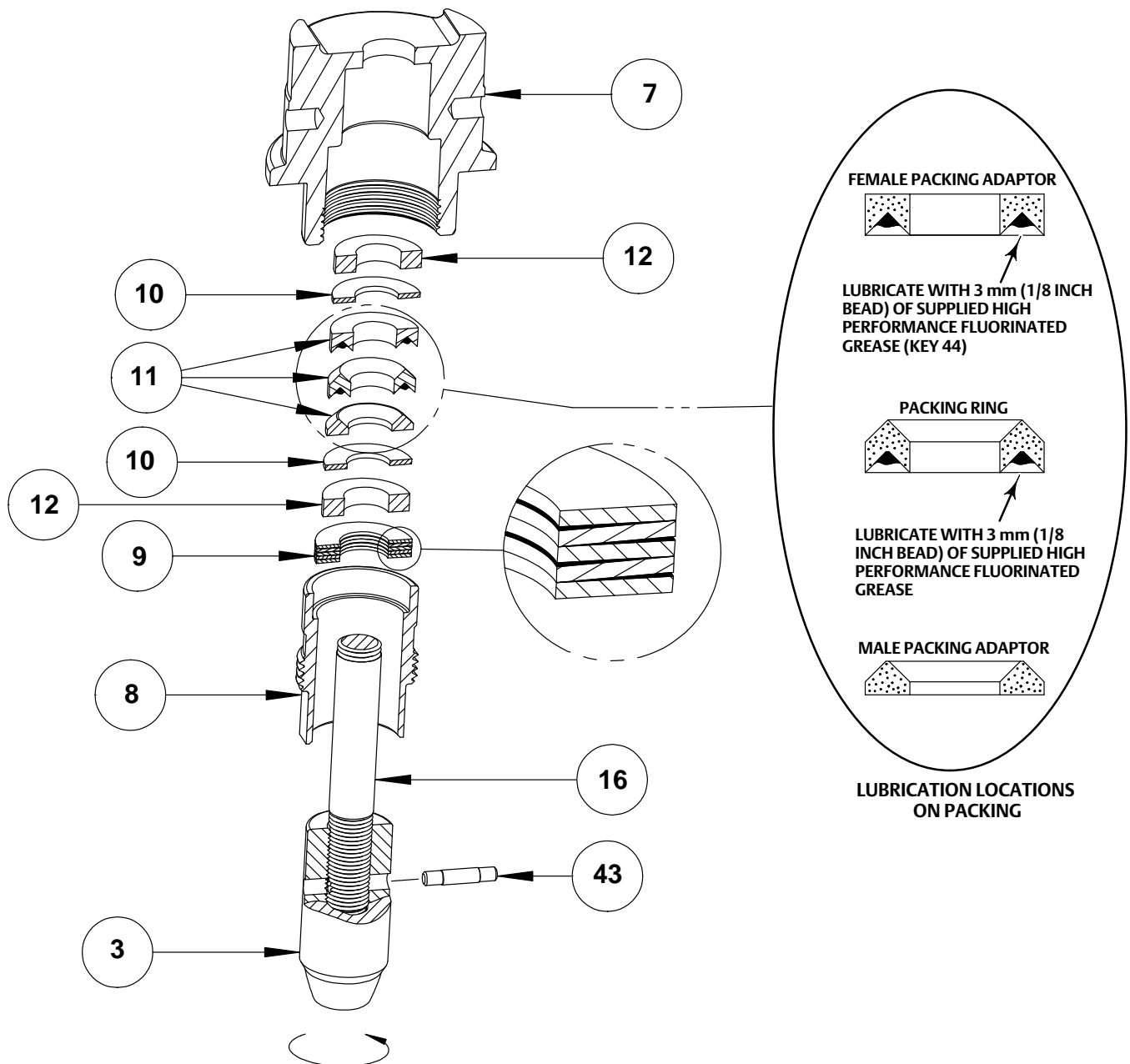
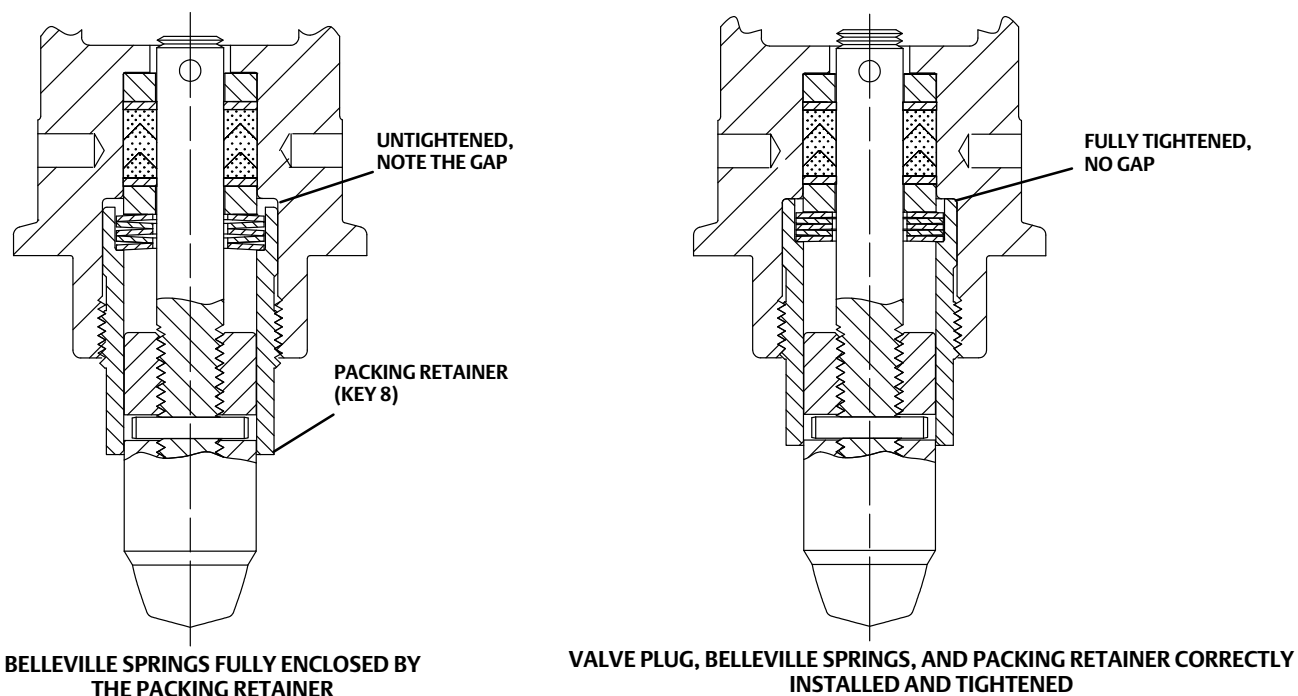

Figure 21. Packing and Belleville Spring Stacking Order



## Valve Plug and Seat Ring Maintenance

### Trim Disassembly

Key numbers are referenced in figures 20, 22, and 23.

1. Isolate the control valve from the line pressure, release pressure from both sides of the valve body (key 1), and drain the process media from both sides of the valve.

### CAUTION

The following steps are intended to prevent damage to the valve plug (key 3) and seat ring (key 2) during the removal of the bonnet and actuator.

#### For ON/OFF Actuators

2. Command the valve open.
3. Place an open end wrench or a similar obstruction about 6 mm (1/4 inch) thick under the FloPro.
4. Command the valve closed.

#### For Positioning Actuators

5. Command the valve to anywhere between 10% and 20% travel.
6. Isolate power and signal.

7. Break the bonnet nut (key 5) loose with a hammer. Continue turning the bonnet nut by using a hammer or a large adjustable wrench, tightened around one ear of the bonnet nut. If the bonnet (key 7) is stuck in the valve, continue to unscrew the bonnet nut. The bonnet nut will contact the spring pins (or pipe plugs) (key 6, figure 22) and jack the bonnet out of the valve. Carefully lift the actuator assembly from the valve body.

### **⚠ WARNING**

**The spring pins/pipe plugs (key 6) must always be in place during valve operation. They provide a safeguard against injury when the unit is being disassembled.**

8. Completely remove the packing retainer (key 8) using a 1-1/8 inch wrench.
9. Remove the valve plug by driving out the pin (key 43) and unscrewing the valve plug from the stem. Do not remove the Belleville springs (key 9) from the stem, in order to retain the Belleville stacking orientation as shown in figure 20.
10. Use a 1-3/16 inch socket wrench to loosen and remove the seat ring (key 2).

### **CAUTION**

**Inspect the seat ring and valve body interior for wear, erosion, or damage in the following steps.**

11. Inspect the seat ring for wear or damage. If the seating surface has been damaged, discard the seat ring.
12. Visually inspect the valve body interior below the seat ring for erosion or damage. Replace the valve body if necessary.

### **⚠ WARNING**

**Be careful to avoid damaging the seating surface on the valve plug or seat ring as damage in these areas will allow excessive leakage at shutoff. Avoid damaging the highly polished valve stem surface. A damaged valve stem could cut the packing and allow process fluid to leak to the atmosphere.**

**Cover the opening in the valve body to prevent foreign material from getting into the valve body cavity.**

## Trim Assembly

1. Ensure the threads of the valve stem (key 16) and valve plug (key 3) are clean and free of debris.
2. Make sure the Belleville springs (key 9) are properly installed on the valve stem, as shown in figure 21.
3. Install the valve plug on the stem and insert a new pin (key 43).
4. Lubricate the threads of the packing retainer with anti-seize and install into the bonnet using a 1-1/8 inch wrench. Make sure the Belleville springs (key 9) are completely enclosed by the packing retainer as shown in figure 21.
5. Torque the packing retainer to 81 N•m (60 lbf•ft). The packing retainer has been installed correctly when a metal-to-metal contact has been made between the packing retainer end and the bonnet (key 7). The packing retainer threads should be completely enclosed by the bonnet (see figure 21).
6. Thoroughly clean the seat ring (key 2) threads and the mating threads in the valve body (key 1).
7. Apply anti-seize lubricant to the threads of the seat ring and its mating threads in the valve body.
8. Screw the seat ring into the valve body. Use a 1-3/16 inch socket wrench to tighten the seat ring to 170 N•m (125 lbf•ft). Remove all excess lubricant after tightening.
9. Lubricate the bonnet O-ring (key 4) with lithium grease and install on the bonnet.

10. Apply anti-seize lubricant to the threads on the valve body and bonnet nut (key 5) and the contact surfaces of the bonnet and bonnet nut flange. Install the bonnet and actuator assembly onto the valve body. Tighten the bonnet nut until the nut stops turning. A few hammer blows will be required to ensure that the assembly is tight.

## Packing Maintenance

### **⚠ WARNING**

**Observe the warning at the start of the Maintenance section.**

Key numbers are referenced in figure 20.

The valve stem packing can only be serviced by removing the bonnet from the valve body.

### Packing Disassembly

1. Disassemble the valve per steps 1 - 9 in the Trim Disassembly section of the Valve Plug and Seat Ring Maintenance section of this manual.
2. Remove the five Belleville springs (key 9), lower packing spacer (key 12), packing set (key 11), and two anti-extrusion washers (key 10) from the bonnet (key 7) using a formed wire hook.
3. Clean and inspect the packing box wall to ensure that the packing surfaces are not damaged. If the surface condition is damaged and cannot be improved by light sanding, replace the bonnet.
4. Inspect the valve stem (key 16) and valve plug (key 3) for scratches or wear and replace if necessary.

### Packing Assembly

The following steps define the proper procedure for installing the packing in a D3 valve. Improper packing assembly can lead to poor valve performance. The proper packing arrangement is shown in figures 20 and 21.

1. Ensure the upper packing spacer (key 12) is installed.
2. Use the lower packing spacer (key 12) and a tube to push the upper anti-extrusion washer (key 10) into place. Using the lower packing spacer in this manner will ensure the upper anti-extrusion washer is fully seated and flat when installed in the packing bore.
3. Remove the lower packing spacer from the packing bore.

### **CAUTION**

**All D3 packing kits include a single use packet of high performance fluorinated grease. This is the only acceptable D3 packing lubricant.**

#### Note

In the following procedure, carefully install each packing ring individually over the valve stem and push completely into the packing box with a non-marring tube. A 12-inch length of 1/2 inch PVC pipe works well for this. It is recommended that the lubricated packing rings be installed individually rather than pushed in as a set.

4. Apply a 3 mm (1/8 inch) bead of the supplied high performance fluorinated grease (key 44) around the groove of the female packing adaptor as shown in figure 20 and install over the valve stem (key 16).
5. Apply a 3 mm (1/8 inch) bead of the supplied high performance fluorinated grease (key 44) around the groove of the packing ring as shown in figure 20 and install over the valve stem.



6. Install the male packing adaptor, lower anti-extrusion washer (key 10), and lower packing spacer over the valve stem as shown in figure 20.
7. Firmly press all packing parts into the packing bore with a tube.
8. Install the five Belleville springs (key 9) over the valve stem as shown in figure 20.
9. Install the valve plug (key 3) on the stem and insert a new groove pin (key 43).
10. Lubricate the threads of the packing retainer with anti-seize and install into the bonnet using a 1-1/8 inch wrench. Make sure the Belleville springs are completely enclosed by the packing retainer as shown in figure 21.
11. Torque the packing retainer to 68 N•m (50 lbf•ft). The packing retainer has been installed correctly when a metal-to-metal contact has been made between the packing retainer end and the bonnet (key 7). The packing retainer threads should be completely enclosed by the bonnet.
12. Apply anti-seize lubricant to the threads on the valve body and bonnet nut (key 5) and the contact surfaces of the bonnet and bonnet nut flange. Install the bonnet and actuator assembly onto the valve body. Tighten the bonnet nut until the nut stops turning. A few hammer blows will be required to ensure that the assembly is tight.

## Stem Replacement

### CAUTION

**If the valve stem is replaced, the packing will also need to be replaced, since the threads on the valve stem may damage the packing when the valve stem is removed.**

1. Follow the Trim Disassembly procedures, steps 1-8 on page 22 of this manual.
2. Ensure power and signal have been isolated from the actuator. Open the explosion-proof enclosure (keys 60 and 61), using a 13 mm wrench.
3. Remove the FloPro (keys 13, 14, and 15), using a 5/32 inch hex head wrench.
4. Remove the stem nut (key 27), using an 11/16 inch wrench, noting the position of the FloPro relative to the bonnet markings.
5. Use a rubber mallet to gently drive the stem downward through the bottom of the actuator housing and remove the stem.
6. Ensure the packing has been removed, using procedures in the Packing Disassembly on page 24 of this manual.
7. Replace the stem by gently pushing the stem up through the actuator.
8. Replace the packing and plug, using the procedures in the Packing Assembly on page 24 of this manual.
9. Install the FloPro at the same position it was removed from in step 4. Tighten the hex socket head cap screws to 3 N•m (26 lbf•in).
10. Tighten the stem nut (key 27) to 39 N•m (29 lbf•ft) using an 11/16 inch wrench. Be sure the FloPro is not allowed to rotate when tightening the stem nut.
11. Apply anti-seize lubricant to the threads on the valve body and bonnet nut (key 5) and the contact surfaces of the bonnet and bonnet nut flange. Install the bonnet and actuator assembly onto the valve body. Tighten the bonnet nut until the nut stops turning. A few hammer blows will be required to ensure that the assembly is tight.

## Parts Ordering

Each D3 control valve is assigned a serial number, which can be found on the nameplate. Refer to the number when contacting your [Emerson sales office](#) for assistance or when ordering replacement parts.

### **⚠ WARNING**

**Use only genuine Fisher replacement parts. Components that are not supplied by Emerson should not, under any circumstances, be used in any Fisher valve, because they may void your warranty, might adversely affect the performance of the valve, and could cause personal injury and property damage.**

## Parts Kits

Trim Kits	Port Diameter (inches)	0.375	0.75	1
	Standard trim kit (Contains keys 2, 3, 4, and 43)		RD3STD0012	RD3STD0022
Carbide trim kit (Contains keys 2, 3, 4, and 43)		RD3CARB042	RD3CARB052	RD3CARB062

Packing Kit (Contains keys 4, 10, 11, 43, and 44)	RD3PACK012
Valve Stem (Key 16)	GE48049X012
Board Replacement Kit (On/Off is default)	GE83055X012
Board Replacement Kit + Positioning License Dongle	GE83126X012
Motor/Gearbox Assembly	GE84237X012
Motor/Gearbox/Board Assembly (On/Off is default)	GE84238X012
Motor/Gearbox/Board Assembly + Positioning License Dongle	GE89047X012
Replacement Kit - Belleville Springs	GE78843X012
Positioning License Dongle (1 License)	GE83574X012
Positioning License Dongle (5 License)	GE83574X022

## Parts List

### Note

Recommended spare parts are included in the Parts Kits shown at the top of this page. Contact your Emerson sales office for Part Ordering information.

Key	Description
-----	-------------

1	Valve Body
2*	Seat Ring
3*	Valve Plug
4*	Bonnet O-ring
5	Bonnet Nut
6	Spring Pin (or alternate pipe plug) (2 req'd)
7	Bonnet
8	Packing Retainer
9	Belleville Springs (5 req'd)
10*	Anti-Extrusion Washer (2 req'd)
11*	Packing Set

Key	Description
-----	-------------

12	Packing Spacer
13	FloPro Half
14	FloPro Half
15	Hex Socket Head Cap Screw (2 req'd)
16*	Stem
18*	O-ring
20	Locknut
25*	Stem O-ring
27	Stem Nut
34	Valve Nameplate
41	Drive Screw (2 req'd)
43*	Groove Pin
44*	High Performance Fluorinated Grease Packing Lubricant
58	Enclosure O-ring
59	Motor/gearbox/controller assembly
60	Upper Enclosure
61	Lower Enclosure
62	Motor Cap Screws (4 req'd)
63	Motor Cap Screw Washers (4 req'd)
64	Enclosure Cap Screws (8 req'd)
65	Enclosure Cap Screw Retaining Washers (8 req'd)
66	Ground Screw
68	Certification Nameplate
69	easy-Drive Label

Figure 22. D3 Valve Assembly

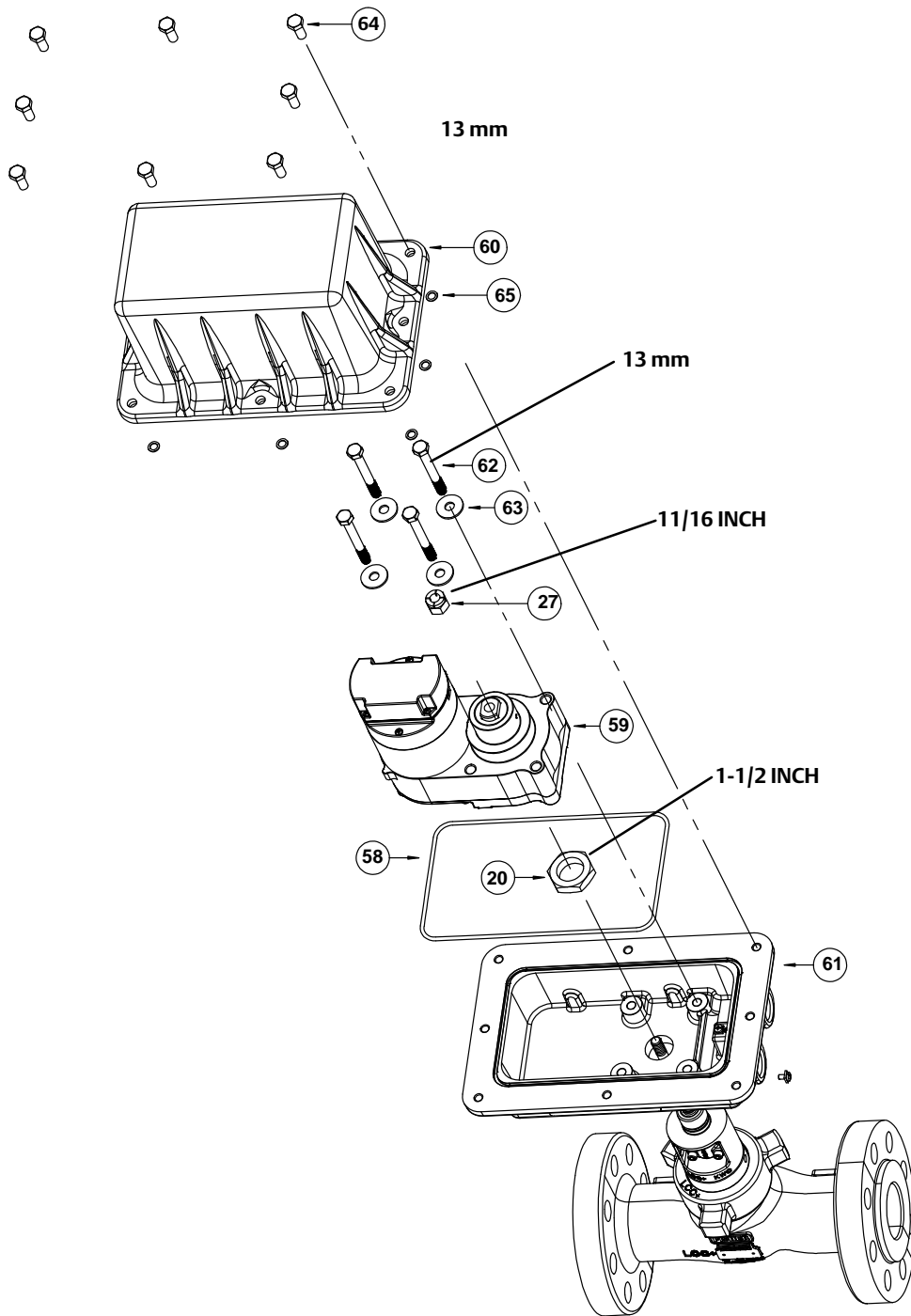
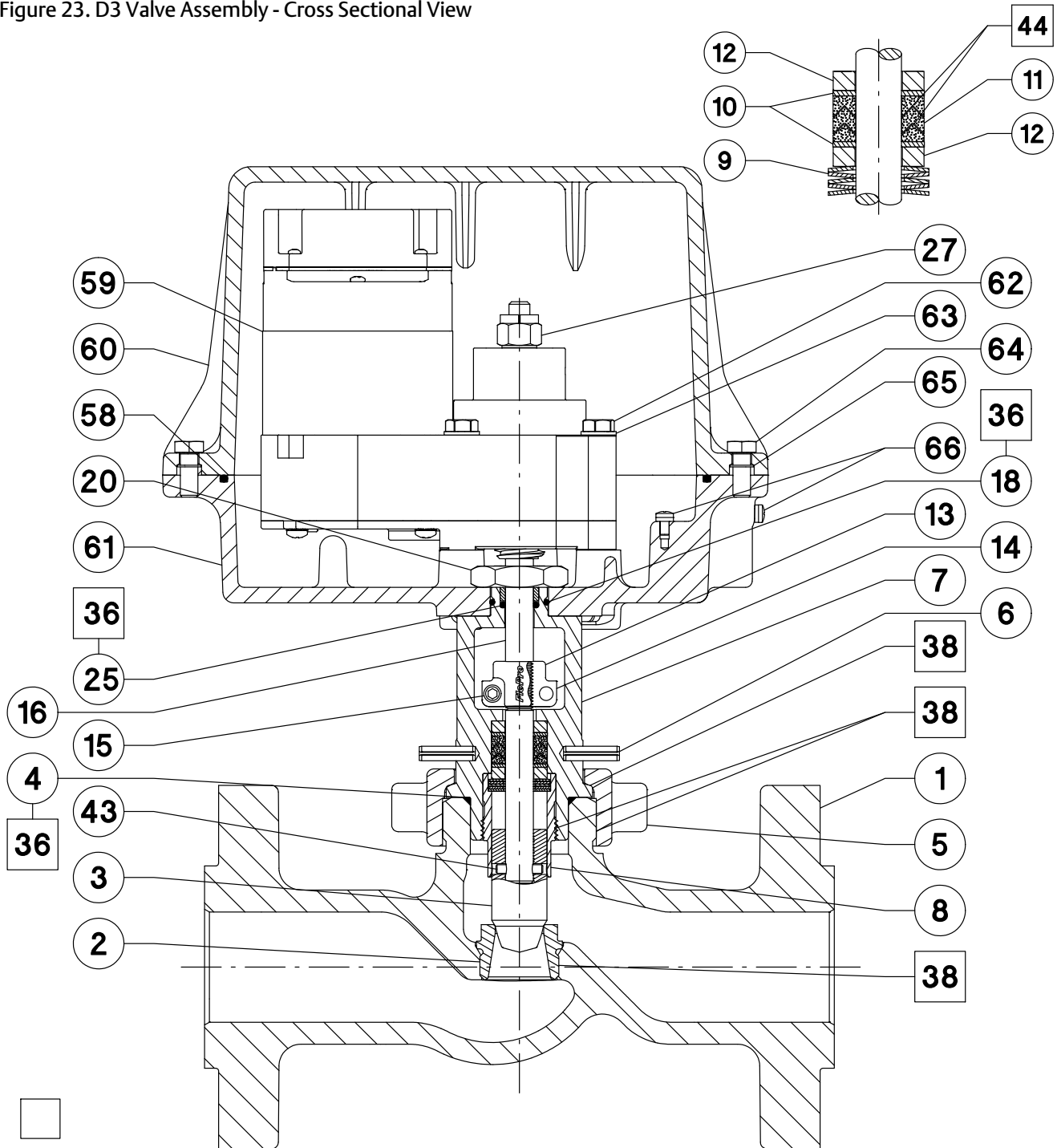

Figure 23. D3 Valve Assembly - Cross Sectional View



# Appendix A - Modbus

## A.1 Register Summary

Table 4. Gen 2 easy-Drive Actuator Modbus Map

Type <sup>(1)</sup>	Name	MB Register	Default	R/W	Values	Notes
uint16	Modbus position command (100=10.0%)	40001	0	R/W	0-1000	Modbus command value with one implied decimal place (1000=100.0%). R/W at all times but only used in Modbus control mode. In on/off mode 0-499 will result in a move to 0% and 500-1000 will result in a move to 100%.
uint16	Digital output	40002	0	R/W	0,1	0=no voltage supplied to terminals, 1=voltage supplied to terminals (Only used when output setup is set for Remote controlled)
uint16	Reset error codes	40003	0	R/W	0,1	Value of 1 will clear faults. Will automatically set back to 0.
uint16	RESERVED	40004				
uint16	RESERVED	40005				
uint16	RESERVED	40006				
uint16	RESERVED	40007				
uint16	RESERVED	40008				
uint16	RESERVED	40009				
uint16	Actual position (100=10.0%)	40010	0	R	0-1000	Present position of the actuator relative to span with 1 implied decimal place (1000=100.0%). Valid for all control modes.
uint16	Commanded position (100=10.0%)	40011	0	R	0-1000	Present position command of the actuator relative to span (1000=100.0%). Valid for all control modes.
uint16	Diagnostic Flags	40012	0	R	0-65535	Bit flags - see chart
uint16	Digital status	40013	0	R	0 - 1	0=no connection between terminals, 1=connection between terminals (Status of digital input or output)
uint32	Total Running Time (min)	40014, 40015	0	R	4294967296	Total number of minutes the actuator has been powered on since time has been reset
uint32	Total Open Time (min)	40016, 40017	0	R	4294967296	Total number of minutes the actuator has been at 100% of travel since time has been reset
uint32	Total Closed Time (min)	40018, 40019	0	R	4294967296	Total number of minutes the actuator has been at 0% of travel since time has been reset
uint32	Number of Closed (Cycle count)	40020, 40021	0	R	4294967296	Total number of close cycles the actuator has performed since reset. One open/close cycle counts as 1.
uint32	Number of Power Cycles	40022, 40023	0	R	4294967296	Total number of times the actuator has been powered on.
uint32	Number of Movements	40024, 40025	0	R	4294967296	Total number of movements the actuator has performed. Move must be at least 5% of rated travel for cycle to increment.
uint16	Analog input control value	40026	0	R	0-2400	Value of the analog signal in mA with 2 implied decimals. In analog control mode, this is the command value and is subject to the analog settings in registers 40046 to 40059. Always active but a slower refresh rate when unit is not in analog control mode.
uint16	Incoming voltage	40027	0	R	0-350	Diagnostic register - value of incoming voltage with 1 implied decimal.
uint16	Latch Open State	40028	0	R	0 - 1	Normally open latch state

-Continued-

Table 4. Gen 2 easy-Drive Actuator Modbus Map (cont.)

Type	Name	MB Register	Default	R/W	Values	Notes
uint16	Latch Close State	40029	0	R	0 - 1	Normally closed latch state
uint16	RESERVED	40030				
uint16	RESERVED	40031				
uint16	RESERVED	40032				
uint16	RESERVED	40033				
uint16	RESERVED	40034				
uint16	RESERVED	40035				
uint16	RESERVED	40036				
uint16	RESERVED	40037				
uint16	RESERVED	40038				
uint16	RESERVED	40039				
uint16	Test Register - 16 bit	40040	45964	R	45964	Fixed register to test correct reading of 16 bit registers - Hex=B38C, Binary=1011001110001100
uint32	Test Register - 32 bit	40041, 40042	3,012,341,331	R	3,012,341,331	Fixed register to test correct reading of 32 bit registers - Hex=B38C AE53, Binary=1011001110001100 1010111001010011
uint16	Span calibration	40043	0	R/W	0,1	Value of 1 will initiate span calibration. Will automatically set back to 0.
uint16	RESERVED	40044				
uint16	RESERVED	40045				
uint16	RESERVED	40046				
uint16	RESERVED	40047				
uint16	RESERVED	40048				
uint16	RESERVED	40049				
uint16	Loss of signal position (100=10.0%)	40050	0	R/W	0-1001	Position to which valve plug will be driven upon loss of signal. Loss of signal is based upon the active control mode. 0-1000=0-100.0% with 1 implied decimal point. In on/off mode 0-499 will result in movement to 0% while 500-1000 will result in movement to 100%. A value of 1001 in any control mode is the setting for "lock-in-last".
uint16	Modbus timeout (s)	40051	60	R/W	0-65535	Time without a valid Modbus message is seen (to any address) before "loss of signal" motion is engaged when in Modbus control mode. Only active in Modbus control mode. 0=disabled
uint16	Dual contact timeout (s)	40052	60	R/W	0-3600	Time without a digital signal being low (contact made) from either digital input as viewed by voltage level on the digital input terminals. If neither contact has been made (pulled input low) within the timeout period, the valve plug will be moved to the loss-of-signal position. Only active in the local, on-off, dual contact mode. 0=disabled.

-Continued-

Table 4. Gen 2 easy-Drive Actuator Modbus Map (cont.)

Type	Name	MB Register	Default	R/W	Values	Notes
uint16	Deadband (10=1.0%)	40053	5	R/W	0-250	Minimum percentage signal change to elicit a movement response based upon end position of last movement. For example, if the previous command resulted in the actuator moving to 31.2% of travel and deadband is set to 100 (10.0%), setpoint must command valve to 21.2% or 41.2% before valve will move to new position. Default is set set to minimize signal dithering.
uint16	Low travel cutoff position (100=10.0%)	40054	50	R/W	0-999	Analog input command, in percent with one implied decimal (50=5.0%), below this value will result in the valve plug moving to the closed position. Active in both local and Modbus control modes.
uint16	Analog on/off close position (100=10.0%)	40055	400	R/W	0-999	When the valve is in 4-20 mA on/off mode, this value is the point at which the valve will close. It must be set to a smaller value than the analog on/off open position. Percentage position value with one implied decimal (400=40.0%).
uint16	Analog on/off open position (100=10.0%)	40056	500	R/W	1-1000	When the valve is in 4-20 mA on/off mode, this value is the point at which the valve will open. It must be set to a larger value than the analog on/off close position. Percentage position value with one implied decimal (500=50.0%).
uint16	Analog Close Value	40057	40	R	31 - 220	The analog value, in mA with one implied decimal (40=4.0 mA), that defines the closed position
uint16	Analog Open Value	40058	200	R	31 - 220	The analog value, in mA with one implied decimal (200=20.0 mA), that defines the open position
uint16	Number of retries	40059	2	R/W	0-4	When the valve plug encounters an obstruction, how many attempts will it make to move past that point, assuming no change in the command signal within the deadband range.
uint16	RESERVED	40060				
uint16	RESERVED	40061				
uint16	RESERVED	40062				
uint16	RESERVED	40063				
uint16	RESERVED	40064				
uint16	RESERVED	40065				
uint16	RESERVED	40066				
uint16	Control Source	40067	0	R/W	0-5	0=Dual Contact On/Off 1=Single Contact On/Off, 2=Modbus On/Off, 3=Modbus Positioning, 4=4-20 Positioning, 5=4-20 Level
uint16	Valve Type	40068	1	R/W	1-10	1=D3, 2=D4
uint16	RESERVED	40069				
uint16	RESERVED	40070				
uint16	RESERVED	40071				
uint16	RESERVED	40072				
uint16	RESERVED	40073				
uint16	Modbus address	40074	1	R/W	1-247	Slave Address of the actuator
uint16	Baud Rate	40075	5	R/W	4,5,6,7	4=4800 baud, 5=9600 baud (default), 6=19200 baud, 7=38400 baud
uint16	Parity	40076	0	R/W	0,1,2	0=Even, 1=Odd, 2=None
uint16	Modbus stop bits	40077	1	R/W	0,1,2	1 stop bit is the standard with even and odd parity while 2 stop bits is the standard for none.
uint16	MSB/LSB	40078	0	R/W	0,1	0=MSB (Big Endian), 1=LSB (Little Endian)

-Continued-

Table 4. Gen 2 easy-Drive Actuator Modbus Map (cont.)

Type	Name	MB Register	Default	R/W	Values	Notes
uint16	RESERVED	40079				
uint16	Digital I/O selection	40080	1	R/W	0,1	0=9 V sinking digital input, 1=25 mA at 10 V digital output
uint16	Digital I/O output setup	40081	0	R/W	0,1,2,3	Valid only when Digital I/O selection is set to Output (1) - 0=In position, 1=Fully closed, 2=Fully open, 3 = Remote controlled (driven by Digital Output register)
uint16	Digital I/O input setup	40082	0	R/W	0,1	Valid only when Digital I/O selection is set to Input (0) - 0=Reference only (status appears in 40013 and does nothing else), 1=Override (status appears in 40013 and valve plug is moved to safe position noted in register 40050)
uint16	RESERVED	40083				
uint16	RESERVED	40084				
uint16	RESERVED	40085				
uint16	RESERVED	40086				
uint16	RESERVED	40087				
uint16	RESERVED	40088				
uint16	RESERVED	40089				
uint16	RESERVED	40090				
uint16	RESERVED	40091				
uint16	RESERVED	40092				
uint16	RESERVED	40093				
uint32	Device Tag	40094-40113	"easyDrive2"	R/W	0 - 255 per character	Device Tag (20 character UTF8 string)
uint32	Valve serial number	40114, 40115	0	R/W*	0-4,294,967,296	Valve assembly serial number assigned at Fisher assembly plant
uint32	Motor serial number	40116, 40117	0	R/W*	0-4,294,967,296	Motor/gearbox serial number
uint32	Motor revision	40118, 40119	0	R/W*	0-4,294,967,296	Motor/gearbox revision
uint32	PCB serial number	40120, 40121	0	R/W*	0-4,294,967,296	PCB serial number
uint16	PCB revision	40122, 40123	0	R/W*	0-4,294,967,296	PCB revision
uint16	Flash Firmware major revision	40124	0	R	0-65535	From flash firmware when compiled
uint16	Flash Firmware minor revision	40125	0	R	0-65535	From flash firmware when compiled
uint16	Flash Firmware mod revision	40126	0	R	0-65535	From flash firmware when compiled
uint16	Flash Firmware build revision	40127	0	R	0-65535	From flash firmware when compiled
uint16	Boot Firmware major revision	40128	0	R	0-65535	From boot firmware when compiled
uint16	Boot Firmware minor revision	40129	0	R	0-65535	From boot firmware when compiled
uint16	Boot Firmware mod revision	40130	0	R	0-65535	From boot firmware when compiled
uint16	Boot Firmware build revision	40131	0	R	0-65535	From boot firmware when compiled
uint32	PCB test date	40132, 40133	0	R/W*	0-4,294,967,296	Seconds since January 1, 2000, Board Supplier Functional Test Date
uint32	Motor test date	40134, 40135	0	R/W*	0-4,294,967,296	Seconds since January 1, 2000, Motor Supplier Test Date
uint32	System completion date	40136, 40137	0	R/W*	0-4,294,967,296	Seconds since January 1, 2000, Final Assembly Test Date

1. uint is defined as unsigned integer  
 uint16 – unsigned 16 bit variable, can take value 0-65535.  
 uint32 – unsigned 32 bit variable, can take value 0-4294967295.  
 (Reserved) – registers used for development use only.



† - 32bit register contains data that spans two registers – reads and write of data needs to be performed within the same Modbus command function to ensure coherency of data.



Table 5. Diagnostic Fault Flags

Hex Value	Bit Mask	Description	Value	Bit	Definition
0x8000	1000 0000 0000 0000	Fault in N.V. Memory – system has restored default settings	32768	15	A memory fault has occurred and the actuator has been restored to factory defaults. Contact your <a href="#">Emerson sales office</a> .
0x8000	1000 0000 0000 0000	Fault in N.V. Memory – system has restored default settings	32768	15	A memory fault has occurred and the actuator has been restored to factory defaults. Contact your Emerson sales office.
0x4000	0100 0000 0000 0000	Motor Assembly Stall - Travel Deviation	16384	14	The actuator is unable to move to the commanded position and has stopped. Follow troubleshooting guide in Help section to remedy.
0x2000	0010 0000 0000 0000	Discrete Input override mode active	8192	13	The digital input has detected a closed contact and the actuator has moved to its safe position. Check switch input device status.
0x1000	0001 0000 0000 0000	System or Watchdog fault	4096	12	The actuator has experienced a fatal error and shut down. Contact your Emerson sales office.
0x0800	0000 1000 0000 0000	Analog Input calibration value not in expected range	2048	11	The analog values entered do not match the analog signal level. Check analog signal value and value entered.
0x0400	0000 0100 0000 0000	Valve travel distance calibration not in legal range	1024	10	The valve travel distance is outside the acceptable range. Confirm valve type and that no obstructions are present.
0x0200	0000 0010 0000 0000	Analog Input span calibration not in legal range	512	9	The analog values for open and close are less than 4 mA and previous values have been maintained. Calibrate analog input with differential >4 mA.
0x0100	0000 0001 0000 0000		256	8	
0x0080	0000 0000 1000 0000	Valve was shutdown while moving	128	7	Actuator was powered down during a move and actual position may vary from commanded. Recalibrate the valve span.
0x0040	0000 0000 0100 0000	Valve span calibrated (informational)	64	6	Span has been calibrated and actuator is ready.
0x0020	0000 0000 0010 0000	Valve position controller active (informational)	32	5	Actuator is active and ready.
0x0010	0000 0000 0001 0000	Loss of signal active	16	4	Control signal not present. Signal is <3 mA, timeout period exceeded (40051 or 40052).
0x0008	0000 0000 0000 1000		8	3	
0x0004	0000 0000 0000 0100	Modbus command has been sent (starts a calibrated system)	4	2	The actuator is successfully moving the valve.
0x0002	0000 0000 0000 0010	Analog input initialized (system has seen input >3 mA/1 V)	2	1	4-20 mA analog input has a valid signal present
0x0001	0000 0000 0000 0001	Start delay active (within 15 second calibration window)	1	0	Span calibration using physical inputs allowed during startup

# Appendix B - Certificate of Conformance

	
<h2>EU Declaration of Conformity</h2>	
We, the manufacturer,	
<b>Emerson</b>	
<b>Fisher Controls International LLC</b>	
<b>205 South Center Street</b>	
<b>Marshalltown, Iowa 50158 USA</b>	
declare under our sole responsibility that the following product(s):	
<b>Electric Actuator</b>	
<b>easy-Drive</b>	
to which this declaration relates, is in conformity with the provisions of the following European Community Directives, including the latest amendments, as shown in the attached schedule.	
Assumption of conformity is based on the application of the harmonized standards and, when applicable or required, a European Community Notified Body certification, as shown in the attached schedule.	
	
<hr style="width: 80%; margin: auto;"/> Bob Stahlin Vice President-Sliding Stem Valve Business Unit Marshalltown, Iowa 50158	
<hr style="width: 80%; margin: auto;"/> 3-August-2020 Date	
<b>European Contact</b> Emerson   Group Services SAS   Rue Paul-Baudry   B.P. 10150   68701 Cernay Cedex France	
EDOCs ID: FCS_55	Page 1 of 2

**EMC Directive – 2014/30/EU**

Models: All  
EN 61326-1:2013

**RoHS Directive – 2011/65/EU**

Declaration of Exclusion

Models: All

The above equipment is excluded from the scope of this directive per Article 2, Paragraph 4, part C. Therefore the equipment cannot bear the CE mark related to RoHS compliance. However, the equipment may bear the CE mark to indicate compliance with other applicable EU directives.

**ATEX Directive – 2014/34/EU (Applicable only if this mark  appears on the product)**

Certificate – **SIRA12ATEX1168X – Group II Category 2 G – Flameproof**  
easy-Drive  
Ex db IIA T6(Ta ≤ 70°C) Gb  
Standards used: EN60079-0:2012/A11:2013, EN60079-1:2014

**ATEX Notified Body for EC-Type Examination Certificate(s)**

CSA Group Netherlands B.V. – Notified Body Number: 2813  
Utrechtseweg 310, Building B42  
6812AR Arnhem  
The Netherlands

**ATEX Notified Body for Quality Assurance**

SGS Fimko Oy – Notified Body Number: 0598  
P.O. Box 30 (Särkiniementie 3)  
Helsinki, 00211  
Finland

Neither Emerson, Emerson Automation Solutions, nor any of their affiliated entities assumes responsibility for the selection, use or maintenance of any product. Responsibility for proper selection, use, and maintenance of any product remains solely with the purchaser and end user.

Fisher and easy-Drive are marks owned by one of the companies in the Emerson Automation Solutions business unit of Emerson Electric Co. Emerson Automation Solutions, Emerson, and the Emerson logo are trademarks and service marks of Emerson Electric Co. All other marks are the property of their respective owners.

The contents of this publication are presented for informational purposes only, and while every effort has been made to ensure their accuracy, they are not to be construed as warranties or guarantees, express or implied, regarding the products or services described herein or their use or applicability. All sales are governed by our terms and conditions, which are available upon request. We reserve the right to modify or improve the designs or specifications of such products at any time without notice.

Emerson Automation Solutions  
Marshalltown, Iowa 50158 USA  
Sorocaba, 18087 Brazil  
Cernay, 68700 France  
Dubai, United Arab Emirates  
Singapore 128461 Singapore

[www.Fisher.com](http://www.Fisher.com)

---

