

September 2018

# V/31-2-AP-E Series Switch for Flow Partition System

## SUMMARY

Introduction.....	1
Characteristics.....	2
Labelling.....	2
Dimensions and Weight.....	2
Installation.....	2
Startup.....	5
SEP Statement.....	5
Field Inspection and Maintenance.....	5
Spare Parts.....	5
Troubleshooting.....	6
Parts List.....	6
Schematic Assemblies.....	7



Figure 1. Types V/31-2-AP-E and V/31-2-AP-EF Switch for Flow Partition System

### WARNING

Failure to follow these instructions or to properly install and maintain this equipment could result in an explosion and/or fire causing property damage and personal injury or death.

Tartarini™ device must be installed, operated and maintained in accordance with federal, state and local codes, rules and regulations and Emerson Process Management Regulator Technologies, Inc. instructions.

If the device vents gas or a leak develops in the system, service to the unit may be required. Failure to correct trouble could result in a hazardous condition.

Call a gas service person to service the unit. Only a qualified person must install or service the device.

## INTRODUCTION

### Scope of the Manual

This manual provides installation, startup, maintenance, troubleshooting, and spare parts for the switch for flow partition system V/31-2-AP-E Series.

### Product Description

In monitor-regulator systems the pneumatic switch Type V/31-2-AP-E is installed on the motorization pressure circuit, in order to obtain the capacity flow partition between the pressure reducing lines.

This product has been designed to be used with fuel gases of 1st and 2nd family according to EN 437, and with other non aggressive and non fuel gases. For any other gases, other than natural gas, please contact your local Sales Office.

For special applications Types V/31-2 -AP-EF, V/31-2-AP-EM and V/31-2-AP-EMF versions are available on request (see Table 1).

# V/31-2-AP-E Series

## CHARACTERISTICS

Table 1. Technical Features

TYPE	ALLOWABLE PRESSURE PS (bar)	SETPOINT TYPE	SET RANGE $W_d$ (bar)	BODY AND COVERS MATERIAL
V/31-2-AP-E	100	Adjustable	0.5 - 2	Steel
V/31-2-AP-EM				
V/31-2-AP-EF		Fixed	2	
V/31-2-AP-EMF				

1/4" NPT female threaded connections.

## LABELLING

Figure 2. Label for V/31-2-AP-E Series Pneumatic Switch

**Note 1:** See "Characteristics"

**Nota 2:** Year of Manufacture

**Nota 3:** Class 1: -10°/60°C  
Class 2: -20°/60°C

**Note 4:** See "Characteristics"

## DIMENSIONS AND WEIGHT

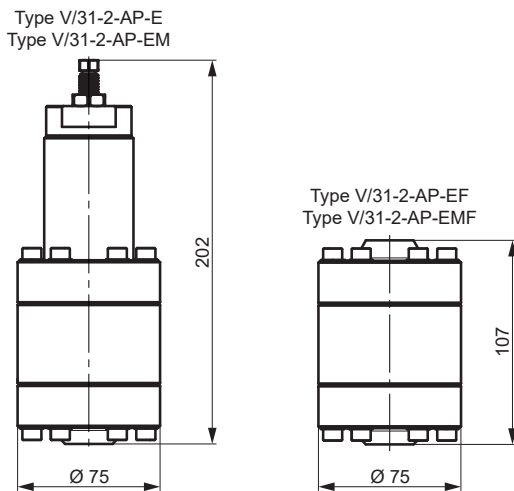

TYPES V/31-2-AP-E and V/31-2-AP-EM WEIGHT: 3.5 kg  
TYPES V/31-2-AP-EF and V/31-2-AP-EMF WEIGHT: 2.9 kg

Figure 3. Dimensions (mm) V/31-2-AP-E Series Pneumatic Switch

## CAUTION

All interventions on the equipment should only be performed by qualified and trained personnel.

For further information, please contact our local Sales Office or our Authorized Dealers.

## INSTALLATION

## WARNING

Personal injury or equipment damage, due to bursting of pressure-containing parts may result if this device is overpressured or is installed where service conditions could exceed the limits given in the Characteristics section and on the appropriate nameplate or where conditions exceed any rating of the adjacent piping or piping connections.

To avoid such injury or damage, provide pressure-relieving or pressure-limiting devices to prevent service conditions from exceeding those limits.

Also, be sure the installation is in compliance with all applicable codes and regulations.

Additionally, physical damage to the device can cause personal injury and property damage due to bursting of pressure-containing parts.

To avoid such injury and damage, install the device in a safe location.

## CAUTION

The device must be rated for the maximum allowable operating pressure of the flow partition system.

- Check that data on the pilot's plate are compatible with actual working conditions.
- Install in accordance with regulator instruction manual.

INSTALLATION (continued)

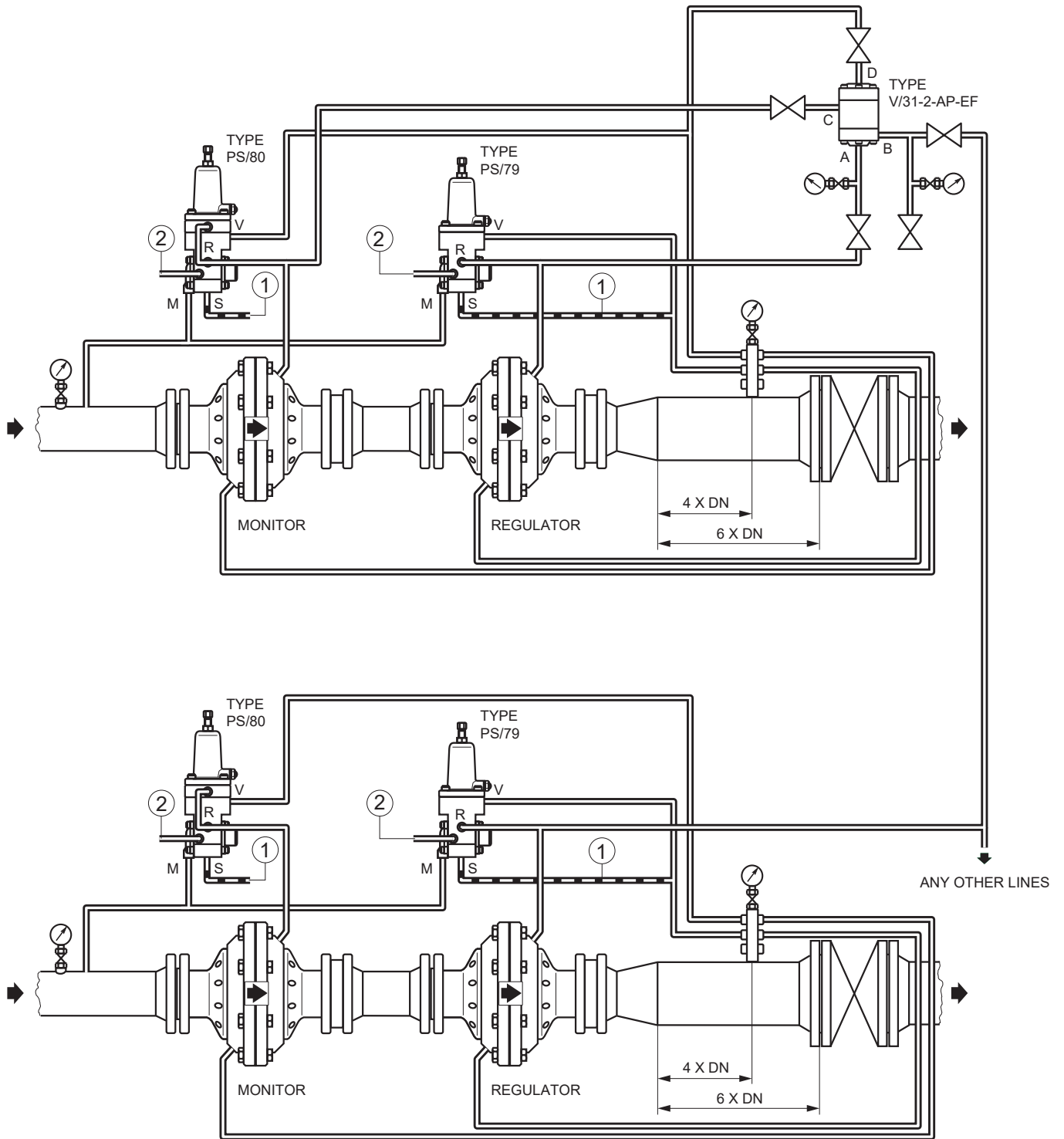

LEGEND:

- ① VENT DOWNSTREAM OR TO A SAFE AREA
- ② TO THE HEATING

NOTE: RECOMMENDED PIPING IS STAINLESS STEEL WITH 10 mm DIAMETER.

Figure 4. Type V/31-2-AP-EF Switch for Flow Partition System Connection/Installation Schematic

# V/31-2-AP-E Series

## INSTALLATION (continued)

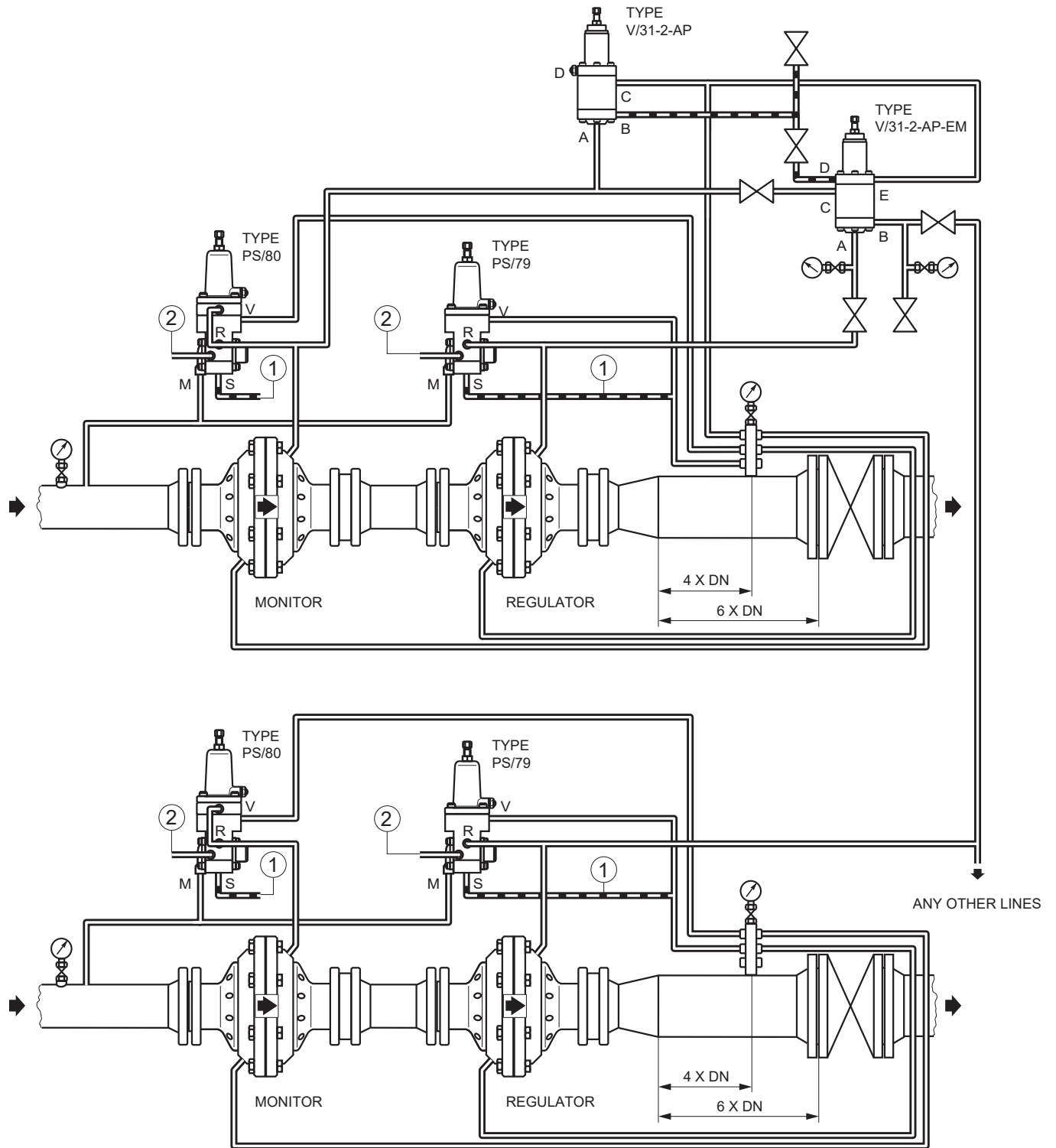

**LEGEND:**

- ① VENT DOWNSTREAM OR TO A SAFE AREA
- ② TO THE HEATING

NOTE: RECOMMENDED PIPING IS STAINLESS STEEL WITH 10 mm DIAMETER.

Figure 5. Type V/31-2-AP-EM Switch for Flow Partition System Connection/Installation Schematic

## STARTUP



**CAUTION**

**Be sure to slowly introduce pressure into the system to prevent downstream overpressure due to potential rapid pressure increase.**

**Pressure gauges should always be used to monitor downstream pressure during Startup.**

See the setup and pilot adjustment instructions applying to the equipment where the switch for flow partition system is fitted.

## SEP STATEMENT

Emerson declares this product conforms to Pressure Equipment Directive PED 2014/68/UE Article 4 section 3 and was designed and manufactured in accordance with sound engineering practice SEP.

Per Article 4 section 3, this “SEP” product must not bear the CE marking.

## FIELD INSPECTION AND MAINTENANCE

The pneumatic switch parts are subject to normal wear and must be inspected periodically and replaced if necessary.

The frequency of inspection/checks and replacement depends upon the severity of service conditions and according to applicable National or Industry codes, standards and regulations/recommendations.

In accordance with applicable National or Industry codes, standards and regulations/recommendations, all hazards covered by specific tests after final assembling before applying the CE marking, shall be covered also after every subsequent reassembly at installation site, in order to ensure that the equipment will be functional throughout its intended life.

Before proceeding with any maintenance work, shutoff the gas upstream and downstream from the regulator, also ensure that there is no gas pressure inside the body by loosening the upstream and downstream connections.

Upon completion, check for leaks using an appropriate leak detection solution.

### Replacing Seal Pad

- a. Disconnect all fittings, remove valve from the line and unscrew (key 4) in the lower part of the valve.  
Remove the lower cover (key 2) and replace pad (key 7).

## General Maintenance



**CAUTION**

**Always remove spring (key 24) tension before performing maintenance on this unit.**

- a. Disconnect all fittings, remove valve from the line, loosen nut (key 19) and unscrew completely adjusting screw (key 18) to remove spring tension.
- b. Unscrew cap (key 20), remove spring holder (key 23) and spring (key 24). Replace O-ring (keys 21 and 22).
- c. Unscrew screws (key 4) and remove the lower cover (key 2). Replace O-ring (keys 13 and 8).
- d. Hold stem (key 9) using a wrench and unscrew nuts (key 16).
- e. Disassemble parts and replace diaphragm (key 12), pad (key 7) and lip seals (key 10).
- f. Unscrew seat (key 5) and replace O-ring (key 6).

## Reassembly

Reassemble all parts by following in reverse order the assembly as described above (see General Maintenance section).

As parts are assembled, make sure they move freely causing no friction.

Make sure to:

- a. O-rings and diaphragms should be lubricated by applying a thin layer of grease Molykote 55 M or equivalent.  
Pay attention not to damage them during reassembly.  
All other pilot parts don't require lubrication.
- b. The cover clamping screws (key 4) should be tightened evenly to ensure proper tightness.
- c. Previously disassembled fittings must be connected. Check for leaks by using suds.

## SPARE PARTS

Spare parts storage shall be done by proper procedures according to national standard/rules to avoid over aging of rubber parts or any damage to critical part.

# V/31-2-AP-E Series

---

## TROUBLESHOOTING

*Table 2. Troubleshooting for V/31-2-AP-E Series Switch for Flow Partition System*

SYMPTOMS	CAUSE	ACTIONS
The booster valve does not work	Valve diaphragm is broken (key 12)	Replace diaphragm

## PARTS LIST

### V/31-2-AP-E Series Switch for Flow Partition System (See Figure 6)

Item	Description
1	Body
2	Lower cover
3	Washer
4	Screw
5	Seat
6*	O-ring
7*	Pad
8*	O-ring
9	Stem
10*	Lip seal
11	Lower plate
12*	Diaphragm
13*	O-ring
14	Upper plate
15	Washer
16	Nut
17	Spring holder
18	Adjusting screw
19	Nut
20	Cap
21*	O-ring
22*	O-ring
23	Spring holder
24	Spring
25	Upper cover
26	Restrictor
27	Label

Rubber parts marked with (\*) are supplied in the "spare parts kit", recommended as stock.

To order the kit it is necessary to communicate to us the pneumatic switch serial number.

**SCHEMATIC ASSEMBLIES**

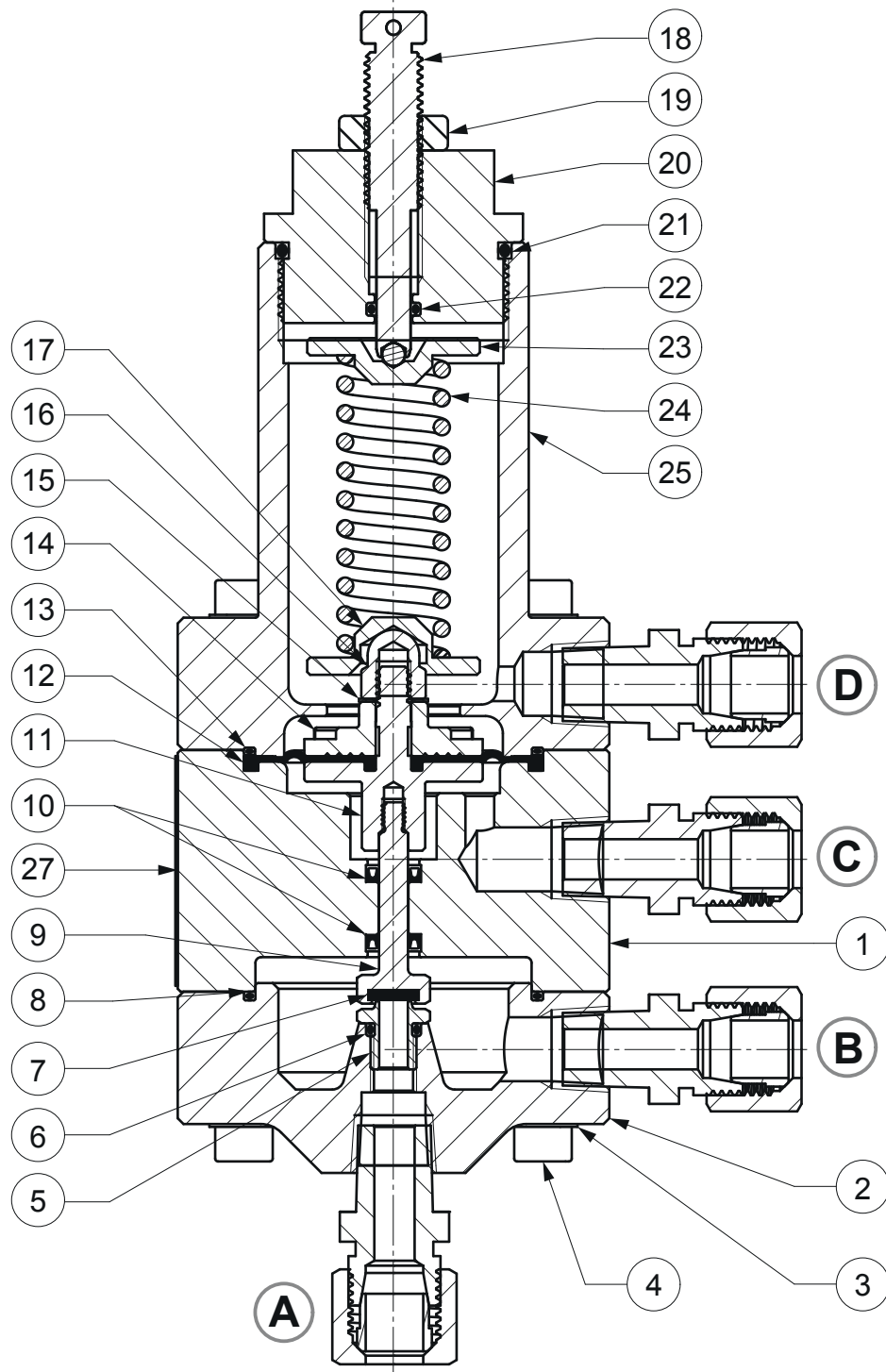

*Figure 6. V/31-2-AP-E Series Switch for Flow Partition System*

# V/31-2-AP-E Series

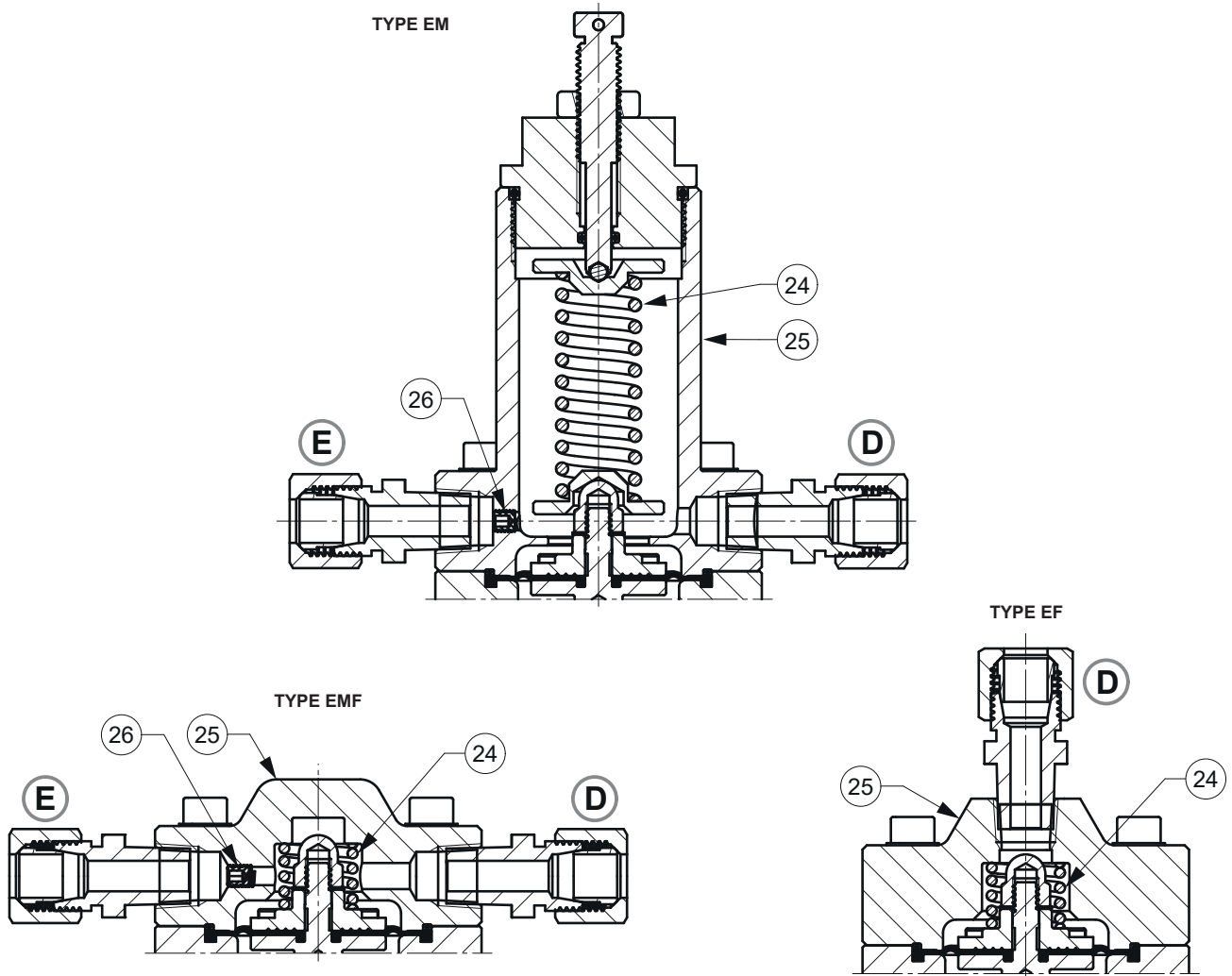

Figure 6. V/31-2-AP-E Series Switch for Flow Partition System (continued)

✉ Webadmin.Regulators@emerson.com

Facebook.com/EmersonAutomationSolutions

🔍 Tartarini-NaturalGas.com

LinkedIn.com/company/emerson-automation-solutions

Twitter.com/emr\_automation

## Emerson Automation Solutions

### Americas

McKinney, Texas 75070 USA  
T +1 800 558 5853  
+1 972 548 3574

### Asia Pacific

Singapore 128461, Singapore  
T +65 6770 8337

### Europe

Bologna 40013, Italy  
T +39 051 419 0611

### Middle East and Africa

Dubai, United Arab Emirates  
T +971 4 811 8100

O.M.T. Officina Meccanica Tartarini S.R.L., Via P. Fabbri 1, I-40013 Castel Maggiore (Bologna), Italy  
R.E.A 184221 BO Cod. Fisc. 00623720372 Part. IVA 00519501209 N° IVA CEE IT 00519501209,  
Cap. Soc. 1.548 000 Euro i.v. R.I. 00623720372 - M BO 020330

Francel SAS, 3 Avenue Victor Hugo, CS 80125, Chartres 28008, France  
SIRET 552 068 637 00057 APE 2651B, N° TVA : FR84552068637, RCS Chartres B 552 068 637,  
SAS capital 534 400 Euro

D104261X012 © 2018 Emerson Process Management Regulator Technologies, Inc. All rights reserved. 09/18.

The Emerson logo is a trademark and service mark of Emerson Electric Co. All other marks are the property of their prospective owners. Tartarini™ is a mark of O.M.T. Officina Meccanica Tartarini s.r.l., a business of Emerson Automation Solutions.

The contents of this publication are presented for information purposes only, and while effort has been made to ensure their accuracy, they are not to be construed as warranties or guarantees, express or implied, regarding the products or services described herein or their use or applicability. All sales are governed by our terms and conditions, which are available on request. We reserve the right to modify or improve the designs or specifications of our products at any time without notice.

Emerson Process Management Regulator Technologies, Inc does not assume responsibility for the selection, use or maintenance of any product. Responsibility for proper selection, use and maintenance of any Emerson Process Management Regulator Technologies, Inc. product remains solely with the purchaser.

