

Fisher™ easy-Drive™ 200L

Contents

Introduction	1
Scope of Manual	1
Description	1
Specifications	3
Educational Services	3
Installation	3
Special Instructions for “Safe Use” and Installations in Hazardous Locations	4
Actuator Mounting	4
Startup Overview	6
Configuration	11
Control Method Configuration	11
Modbus Setup	11
Connecting using the Fisher easy-Drive configuration software	12
Initial Setup	13
Calibration Instructions	13
Operational Verification	15
Troubleshooting	17
Maintenance	18
Disassembly	18
Parts Ordering	21
Parts Kits	21
Parts List	21
Appendix A - Modbus	23
Appendix B - Certificate of Conformance	29

Figure 1. Fisher easy-Drive 200L



Introduction

Scope of Manual

If the actuator has a RPU-100 installed refer to easy-Drive RPU-100 Instruction Manual ([D104551X012](#)).



This instruction manual provides installation, maintenance, and parts information for the easy-Drive 200L. Do not install, operate, or maintain an easy-Drive 200L without being fully trained and qualified in valve, actuator, and accessory installation, operation, and maintenance. To avoid personal injury or property damage, it is important to carefully read, understand, and follow all the contents of this manual, including all safety cautions and warnings. If you have any questions about these instructions, contact your [Emerson sales office](#) before proceeding.

Description

The easy-Drive 200L is a compact, rugged electric actuator designed primarily for high-pressure throttling applications. This actuator is ideal for use on pressure and flow control applications.

Table 1. Specifications

<p>Available Actuator Configurations</p> <p>Positioning</p> <p>Power Requirements</p> <p>11-30 VDC, minimum 4 amp power supply required (fuse to 5 amps)</p> <p>Material Temperature Capabilities</p> <p>Electric Actuator Assembly: -20°C (-4°F) to 70°C (158°F)</p> <p>Maximum Current Draw</p> <p>4 amps</p> <p>Idle Current Draw</p> <p>15 mA at 24 VDC, 25 mA at 12 VDC</p> <p>Conduit Connections</p> <p>Two 3/4 NPT connections</p> <p>Maximum Stroke Length</p> <p>19 mm (0.75 inch)</p> <p>Maximum Thrust</p> <p>3336 N (750 lbf)</p>	<p>Average Thrust</p> <p>2446 N (550 lbf)</p> <p>Nominal Stroke Speed⁽¹⁾</p> <p>3.9 mm/s (0.15 inch/s) at 24 VDC 2.2 mm/s (0.09 inch/s) at 12 VDC</p> <p>Hazardous Area Approvals</p> <p>CSA (C/US): Explosion-Proof Class I, Division 1, Groups C and D, T6, Ex db IIA T6, Class I, Zone 1, AEx db IIA T6 ATEX Flameproof - Gas: ⊕ II 2 G, Ex db IIA T6 Gb IECEx Flameproof - Gas: Ex db IIA T6 Gb</p> <p>Enclosure Rating</p> <p>Type 4X and IP66</p> <p>Duty Cycle</p> <p>50% maximum</p> <p>Enclosure Material</p> <p>Cast aluminum alloy with powder coat paint</p> <p>Approximate Weight</p> <p>9.5 kg (21 lbs)</p>
--	---

1. 10% variation can be expected, based on temperature and pressure of application.

Specifications

Table 1 lists specifications for the easy-Drive 200L. Some of the specifications for a given actuator as it originally comes from the factory are stamped on a nameplate located on the lower actuator enclosure.

Educational Services

Emerson Educational Services
Phone: +1-800-338-8158
E-mail: education@emerson.com
emerson.com/mytraining

Installation

⚠ WARNING

Always wear protective gloves, clothing, and eyewear when performing any installation operations to avoid personal injury.

To avoid personal injury or property damage caused by bursting of pressure-retaining parts or by uncontrolled process fluid, be certain the service conditions do not exceed the limits shown on the valve nameplate and in table 1. Use pressure-relieving devices required by government or accepted industry codes and good engineering practices.

Check with your process or safety engineer for any additional measures that must be taken to protect against process media.

If installing into an existing application, also refer to the **WARNING** at the beginning of the Maintenance section in this instruction manual.

⚠ WARNING

For explosion-proof applications, ensure the actuator cover is properly bolted before applying power to the actuator. Personal injury or property damage may result from fire or explosion if power is applied to the actuator with the cover removed in a hazardous area.

For explosion-proof applications, install rigid metal conduit and a conduit seal no more than 457 mm (18 in) from the actuator. Personal injury or property damage may result from explosion if the seal is not installed.

Select wiring and/or cable glands that are rated for the environment of use (such as hazardous area, ingress protection, and temperature). Failure to use properly rated wiring and/or cable glands can result in personal injury or property damage from fire or explosion.

Wiring connections must be in accordance with local, regional, and national codes for any given hazardous area approval. Failure to follow the local, regional, and national codes could result in personal injury or property damage from fire or explosion.

⚠ WARNING

Avoid personal injury or property damage caused by possible actuator failure. The use of a rigidly-mounted support on the actuator casing may cause additional stress on the actuator leading to premature wear and/or failure of the actuator components.

1. The easy-Drive 200L can be installed in any position, but normally the actuator is vertical above the valve. Install the valve per the manufacturer's guidelines and per any applicable local, regional, and national piping codes.
2. For explosion-proof applications, install rigid metal conduit and seal no more than 457 mm (18 in) from the actuator.
3. Unused conduit ports must be sealed with an explosion-proof port plug.

Note

Plastic conduit ports provided by factory are to be removed prior to operation and replaced with an explosion-proof port plug.

Special Instructions for “Safe Use” and Installations in Hazardous Locations

⚠ WARNING

To avoid static discharge from the enclosure, do not rub or clean the enclosure with solvents. To do so could result in an explosion. Clean with a mild detergent and water only.

The enclosure is non-conducting and may generate an ignition-capable level of electrostatic charges under certain extreme conditions. The user should ensure that the equipment is not installed in a location where it may be subjected to external conditions (such as high-pressure steam) which might cause a build-up of electrostatic charges on non-conducting surfaces. Additionally, cleaning of the equipment shall only be done with a damp cloth.

To avoid damage to the enclosure, when screws are fully tightened into blind holes in enclosure walls, with no washer fitted, at least one full thread shall remain free at the base of the hole.

Actuator Mounting

The following procedure describes how to mount an easy-Drive 200L actuator.

The actuator is shipped with the stem in the ideal coupling position; 6% off the lower actuator stop.

Note

Do not stroke the actuator prior to coupling the unit to the valve.

To reposition the actuator to the ideal coupling position calibrate the actuator as valve type “Stop-to-Stop”. Ensure the actuator is able to travel making contact with its internal stops. Once calibration is complete command the valve to 6% open.

User designed and manufactured Mounting Kit and Stem Coupler will be needed to complete this procedure.

⚠ WARNING

To avoid personal injury or property damage, keep hands and tools out of the actuator stem travel path when moving the actuator stem in the following steps.

1. Supply a method of supporting the weight of the valve and actuator during assembly.
 2. Push the valve stem down away from the actuator to the closed position for push down to close valves.
 3. Mount the easy-Drive 200L to the mounting kit designed and supplied by the user.
 - a. Utilizing the wrench flats on the actuator yoke tighten the actuator yoke locknut to 205 N•m (151lb•ft).
 4. Lift or hoist the actuator and mounting assembly onto the valve and mate the mounting kit securely to the valve following the valve manufacturer's guidelines.
-

Note

The valve stem must be fully in the down position.

5. Make the stem connection between the actuator and valve stems.
 - a. When installing the user-supplied stem connector the actuator stem's threads should engage the threads of the stem connector by a distance equal to or greater than the diameter of the actuator stem.

NOTICE

Incomplete engagement of the actuator stem in the stem connector can result in stripped threads or improper operation. Be sure that the length of each stem clamped in the stem connector is equal to or greater than one diameter of that stem. Damage to threads on either stem or in the stem connector can cause the parts to be replaced prematurely. Do not attempt to remove the stem connector when force is applied to the stem.

6. Configure the actuator to the appropriate mode using the easy-Drive configurator tool. See Valve Type Configuration section of this manual.
7. Calibrate the actuator. See Calibration Instructions section of this manual.

Startup Overview

Figure 2. Flowchart

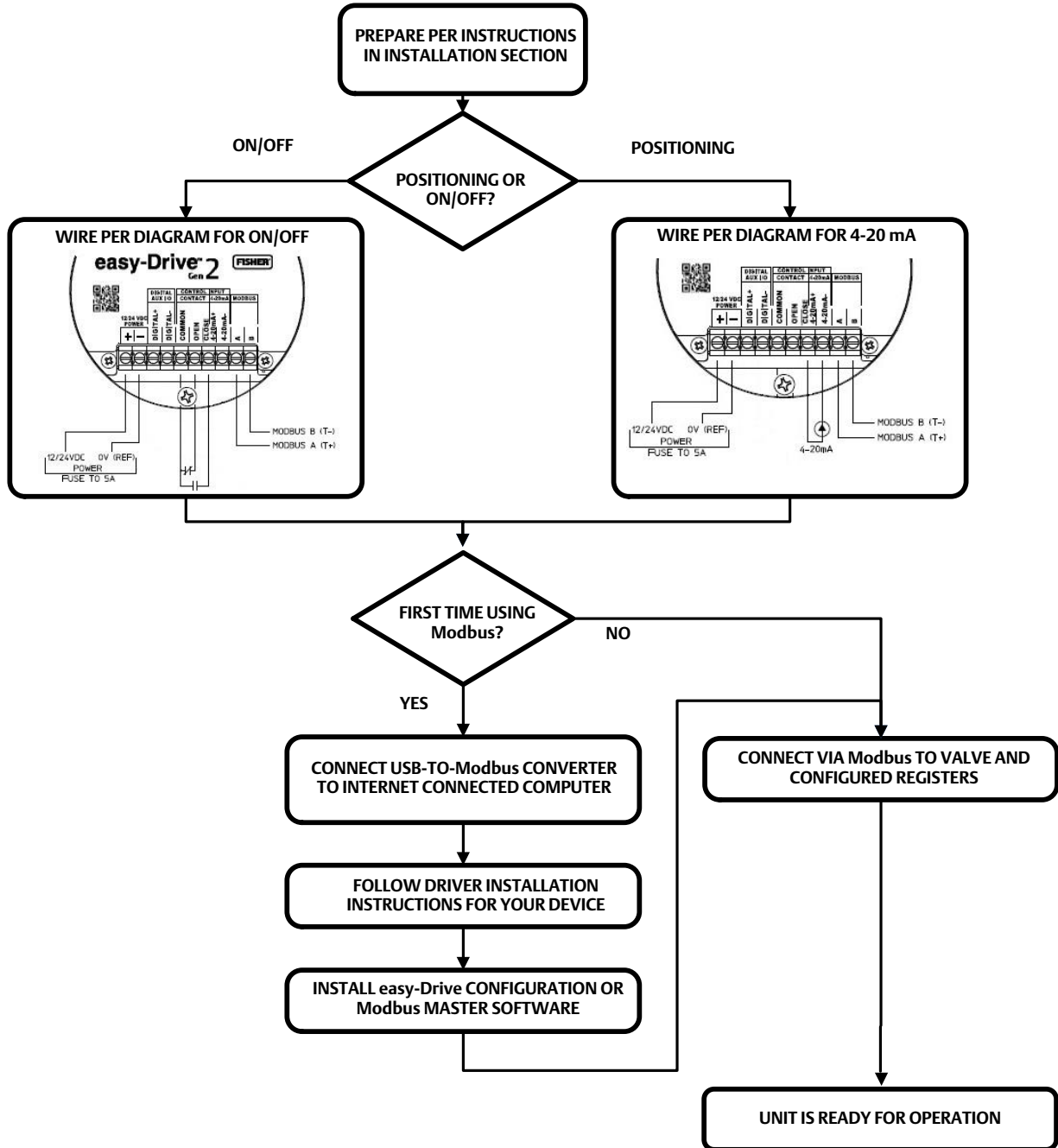
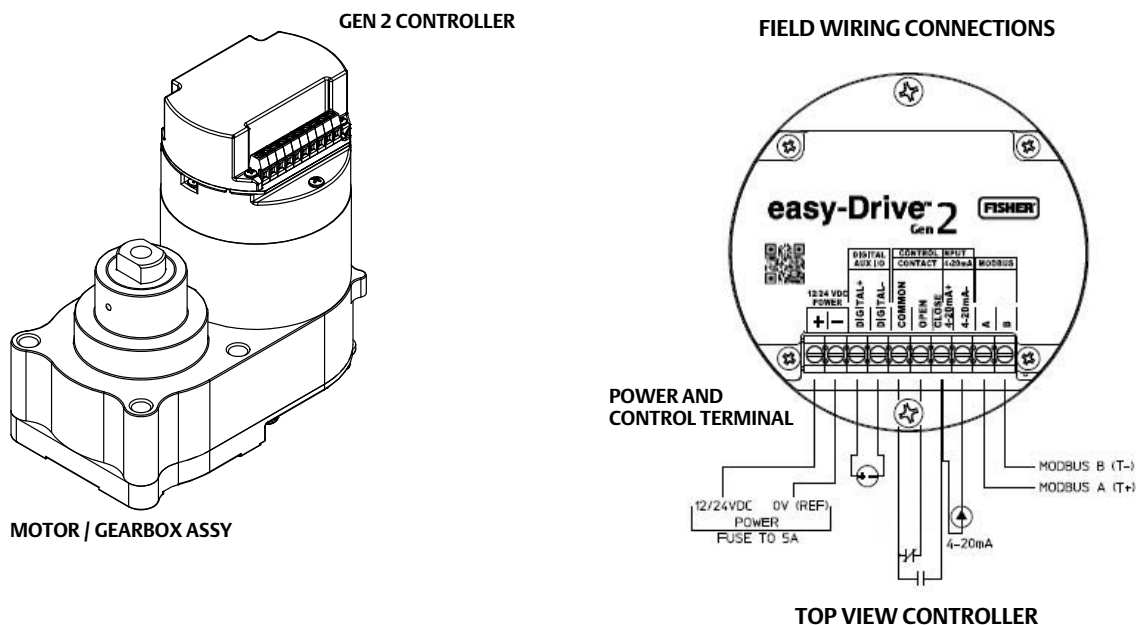

Figure 3. Fisher easy-Drive 200L Wiring Diagram



GE47302-7

Power Requirements

Ensure a stable DC power source is available, maintaining less than 5% ripple and sufficiently surge protected for the application. A 4 amp (minimum) power supply is required.

Wiring Instructions

1. Observe local wiring requirements for hazardous location usage.
2. Conduit seals within 450 mm (18 inches) of the enclosure port are required for explosion-proof installation.
3. 18 AWG (0.52 mm²) to 12 AWG (3.31 mm²) wire size required.
4. Fuse system to 5A.
5. Connect enclosure and analog signal shields.
6. Ensure power is turned off before connecting the wires.

Power

1. Connect 12 or 24 VDC reference to: -
2. Connect 12 or 24 VDC positive to: +
3. Be sure to tighten terminals sufficiently to ensure solid mechanical connection.

Figure 4. Wiring - Analog Input

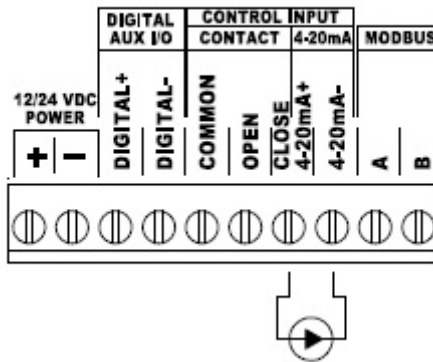

Figure 5. Wiring - Dual Dry Contact

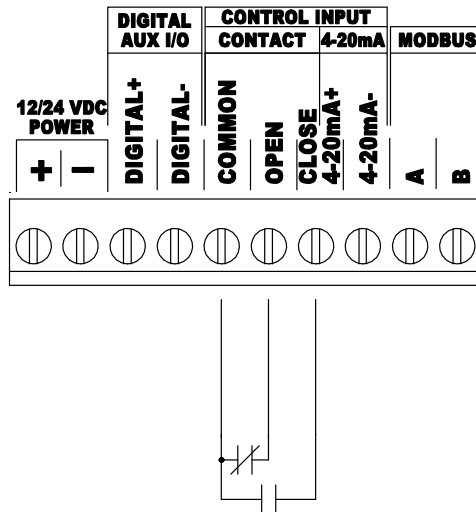

Figure 6. Wiring - Single Dry Contact

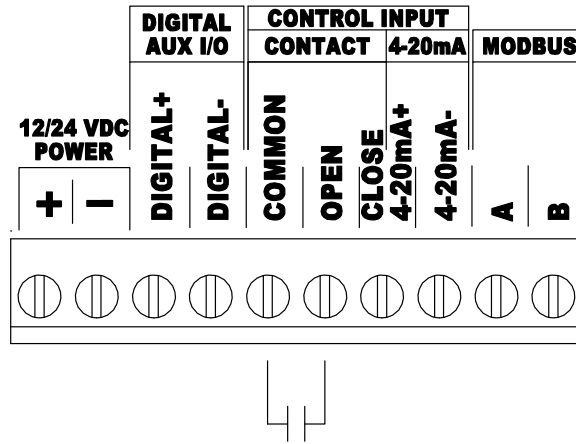

Figure 7. Wiring - Modbus Input

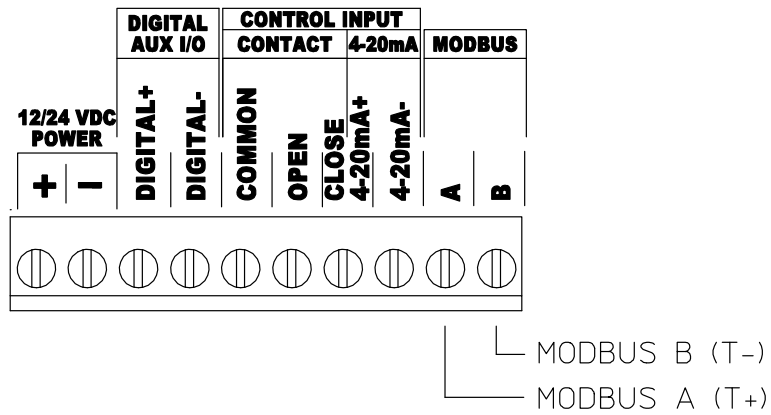

Figure 8. Wiring - Auxiliary Digital I/O set to input (40080=0)

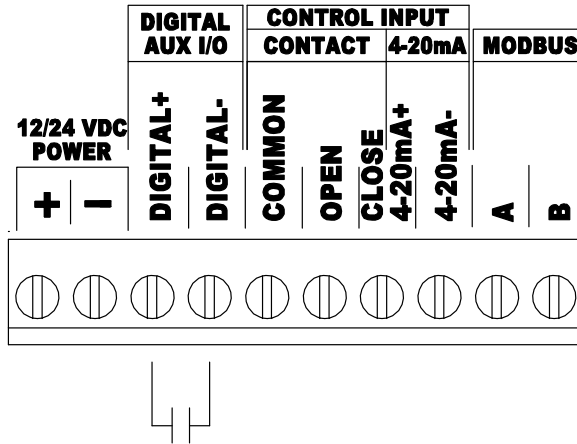
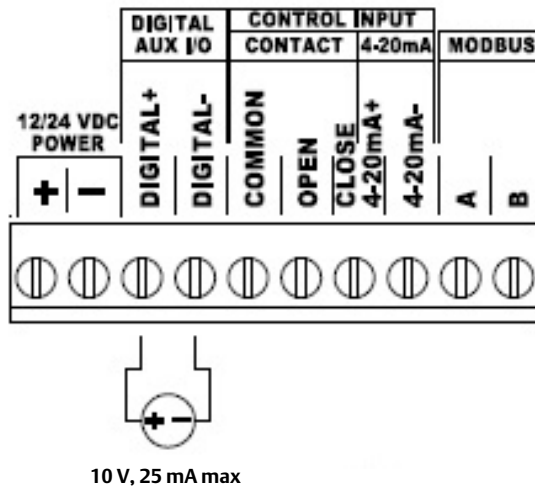

Figure 9. Wiring - Auxiliary Digital I/O set to output (40080=1)



Configuration

The easy-Drive 200L must be configured prior to operation.

All configuration within the actuator is done by setting values in Modbus registers. Configuration software, providing a visual interface to the registers, is available through your Emerson sales office or at www.fisher.com/easydrive. Control and monitoring can be done using any Modbus master (flow computer, PLC, PC).

See Appendix A for a full map of Modbus registers and their functions.

Control Method Configuration

There are two functional configurations available for the easy-Drive electric actuator: On/Off and Positioning.

All available input signals are shown in table 2.

Table 2. All Available Input Signals

CONFIGURATION	ON/OFF			POSITIONING	
Control Source	Modbus	Local		Modbus	Local
Input Signal	Modbus	Dual Dry Contact	Single Dry Contact	Modbus	4-20 mA (default)

Modbus setup

Use of a serial or USB to RS-485 device is required to connect to the actuator. Refer to manufacturer's requirements for installation. The easy-Drive 200L Modbus factory defaults are Address 1, 9600 baud, even parity, 1 stop bit, MSB.

When a connection has been achieved, the actuator may be configured as required for the application.

Figure 10. Fisher easy-Drive Configuration Software



Connecting using the Fisher easy-Drive configuration software

The Fisher easy-Drive configuration software allows configuration and diagnosing of the Fisher easy-Drive electric actuator with a graphical interface. Connect a PC to the actuator using a USB or serial device to RS-485 converter using the wiring instructions above. The USB or serial device will be visible in the drop menu under Serial Port Settings. Baud rate and parity should be set to the Modbus settings of the actuator. Default actuator settings are address 1, 9600 baud, even parity, 1 stop bit, MSB. Press the AUTO button in the upper left corner to connect to the valve.

Use the Fisher easy-Drive configuration software (figure 10) to make the desired changes, or register values may be changed to allow different functionality.

Valve Type Configuration

- Valve Type
 - 0.5" Fixed
 - 0.62" Fixed
 - 0.75" Fixed
 - Stop-to-Stop

Figure 11. Fisher easy-Drive Configuration Software

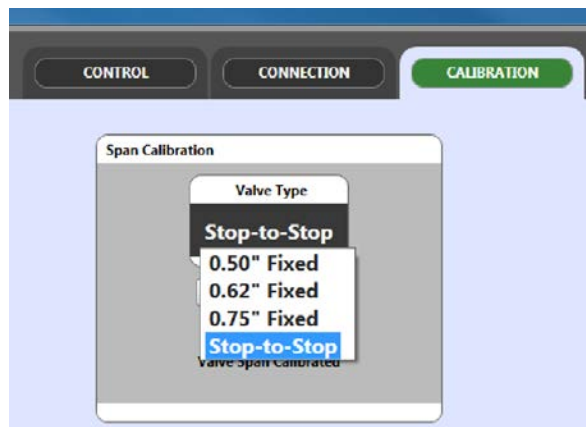

Fixed travel settings will set the fixed travel from the valve seat (push down to close) up, i.e., 0.50" Fixed, will set the full range of travel at 0.5 inches from the seat.

Stop-to-stop setting will set the travel using hard stops that define the full range (max 0.75 inches).

Initial Setup

The control method selection determines the control signal to which the valve will respond. Only the control signal selected will result in movement of the valve; all others will be ignored.

- Control Methods
 - Dual Contact On/Off
 - Single Contact On/Off
 - Modbus On/Off
 - Modbus Positioning
 - 4-20mA Positioning
 - 4-20mA Level

When using the easy-Drive Configuration Tool, clicking on the “Control Method” box will create a drop down menu as shown. Select the desired control source; the selection will turn yellow. A box with Pending Changes will appear showing all changes. Press “APPLY” to confirm the change(s).

Figure 12. Fisher easy-Drive Configuration Software



Calibration Instructions

⚠ WARNING

To avoid personal injury or property damage, be aware that the valve will move during the calibration cycle.

Span Calibration

It will be necessary to perform a span calibration. A span calibration is accomplished by the following method:

1. Ensure the process and valve are in a safe state – the valve may move during this operation.
2. Press the “CALIBRATE SPAN” button to initiate the span calibration. The software will show a progress bar during the calibration and display “Valve Span Calibrated” when complete.

Note

Should actual travel not equal the expected travel you will receive a span calibration failure alert. See figure 13. Ensure valve type is selected correctly. It may be necessary to re-couple the valve actuator assembly.

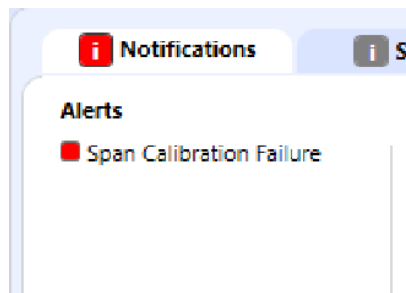
Figure 13. Fisher easy-Drive Configuration Software

Span Calibration without the use of Modbus

1. Turn power to the actuator off.
2. Wait for 10 seconds to ensure all circuits have discharged.
3. Return power to the actuator and use the appropriate calibration method for your control signal. Calibration sequence must be done within 15 seconds of power being switched on.
4. For positioning operation using 4-20 mA:
 - a. Apply a 4 mA signal between pins 4-20 mA - and 4-20 mA +. If Span is currently uncalibrated, valve plug will not move at this time.
 - b. Apply a 20 mA signal between pins 4-20 mA - and 4-20 mA +. If Span is currently uncalibrated, valve plug will not move at this time.
 - c. Apply a 4 mA signal between pins 4-20 mA - and 4-20 mA + – valve plug will move to the upper stop, immediately followed by moving to the lower, closed position.
 - d. If calibration of the analog input is desired to improve positional accuracy, an optional operation is listed in the next section titled Analog Input Calibration.
5. For On/Off operation using dual-input dry contact:
 - a. Close the contact to create a short between pins COMMON and CLOSE. If Span is currently uncalibrated, valve plug will not move at this time.
 - b. Close the contact to create a short between pins COMMON and OPEN. If Span is currently uncalibrated, valve plug will not move at this time.
 - c. Close the contact to create a short between pins COMMON and CLOSE – valve plug will move to the upper, open position and then to the lower, closed position.

6. For On/Off operation using single dry contact:
 - a. Open the contact to create an open circuit between pins COMMON and OPEN. If Span is currently uncalibrated, valve plug will not move at this time.
 - b. Close the contact to create a short between pins COMMON and OPEN. If Span is currently uncalibrated, valve plug will not move at this time.
 - c. Open the contact to create an open circuit between pins COMMON and OPEN – valve plug will move to the upper, open position and then to the lower, closed position.
7. The unit is now calibrated.

Analog Input Calibration

For valves using 4-20 mA as a control source, several options are available to customize control of the actuator. Use a 4-20 mA signal generator to provide the desired signal. It is possible to calibrate the 4-20 mA signal in reverse acting or split-ranging with the method below with at least 4 mA of signal difference between the close and open values. The example shows a valve being changed from normal to reverse acting during the calibration process.

1. With the Control Method set to 4-20 Positioning or 4-20 mA Level, enter the Calibration screen and the 4-20 mA Signal Calibration window will be visible.
2. Click the CALIBRATE CLOSE & OPEN VALUES button. A separate window will open to guide through the process.
3. Set the 4-20 mA signal to the desired value for when the valve is to be closed.
4. Enter this value into the Calibrated mA Signal text box and press Next.

Figure 14. Fisher easy-Drive Configuration Software

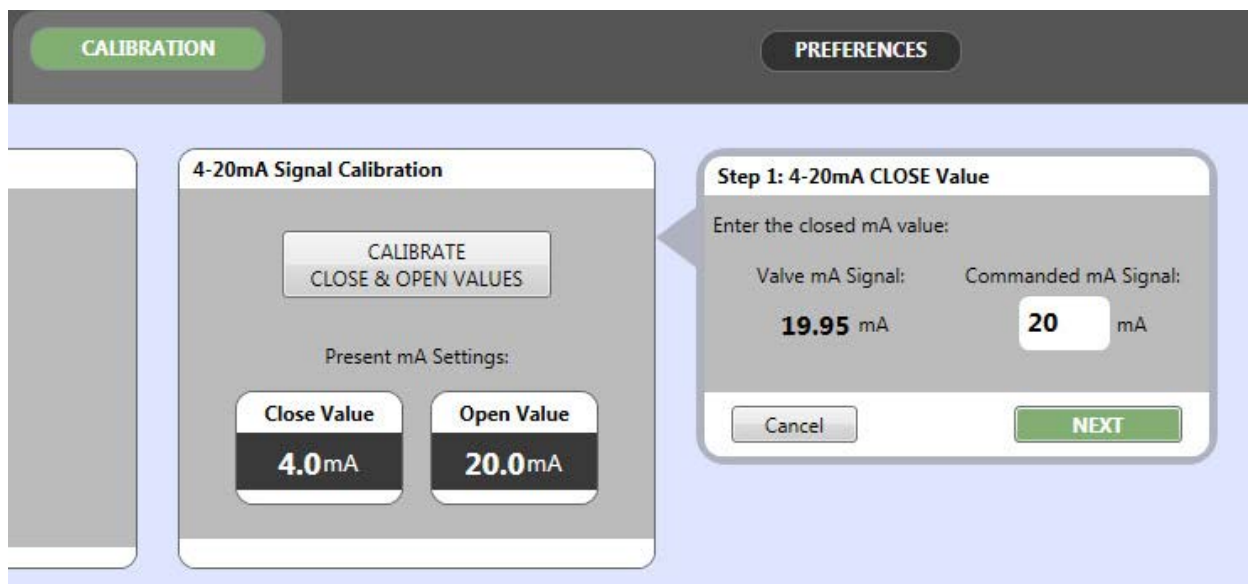

5. Set the 4-20 mA signal to the desired value for when the valve is to be open.
6. Enter this value into the Commanded mA Signal text box and press Next.

Figure 15. Fisher easy-Drive Configuration Software

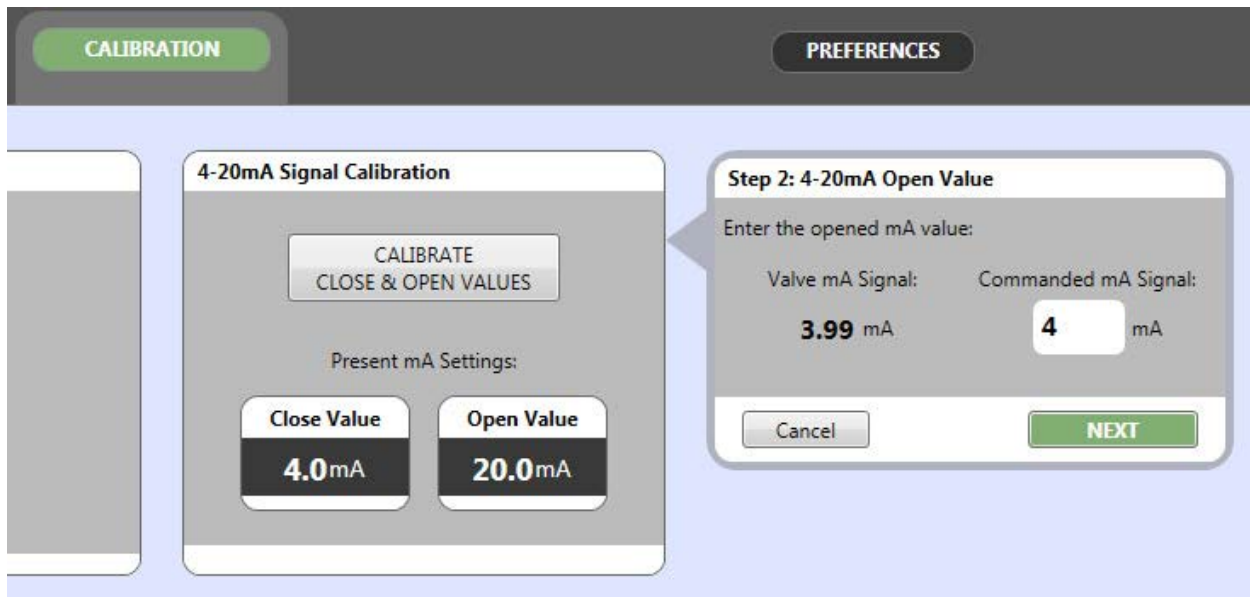

7. If the Close and Open values are as expected, press Confirm to accept these values. If not, press Cancel to restart the process.

Note

The value of the 4-20 mA signal must have at least 4 mA difference between the close and open signals. A differential less than that amount will cause the actuator to reject the calibration and use the previous values.

Should the entered values vary more than 10% from the expected 4-20 mA values; the actuator will accept the calibration and a Notification displaying “Questionable Analog Calibration” will result.

Figure 16. Fisher easy-Drive Configuration Software

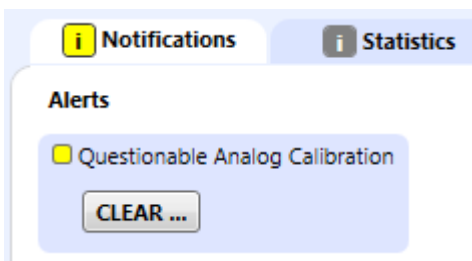

Operational Verification

⚠ WARNING

To avoid personal injury or property damage, be aware that the valve will move and respond to an input signal during start up.

1. Before turning on power to the unit, be sure that a closed signal is being commanded to the unit.
 - Single Dry-Contact: contact is open.
 - Dual Dry Contact: Contact closed across pins COMMON and CLOSE.
 - Analog Input: signal = 4 mA.
 - Modbus: position demand = 0.
2. Turn on power to the unit.
3. Apply a change in position demand to ensure unit responds properly.
 - Single Dry-Contact:
 - Closed contact between pins COMMON and OPEN will open the valve.
 - Dual dry contact: Closed contact between pins COMMON and OPEN will open the valve. Closed contact between pins COMMON and CLOSE will close the valve.
 - Analog Input: valve will respond to proportional demand.
 - Modbus: valve will respond to positional demand in register 40001. 0 = fully closed and 1000 = fully open.
4. If the valve does not respond as expected, proceed to Troubleshooting guide on page 17.
5. Check conduit ports
 - Conduit seal must be in place within 450 mm (18 in) of the enclosure.
 - Unused conduit ports must be sealed with an explosion-proof port plug.
6. Replace the cover and tighten all 8 bolts to 20 N•m (15 ft•lbs).

Troubleshooting

1. Unit does not move.
 - a. Green heartbeat LED will pulse near Modbus terminals when power is present. Verify the 12VDC to 24VDC is present on the power terminals as shown on the cover.
 - b. Verify all wires are firmly attached on both ends.
 - c. Verify the wires are connected to the correct terminals - see Wiring in the manual.
 - d. Verify the configured control method matches control signal.
2. Unit does not respond to 4-20 mA signal
 - a. Green heartbeat LED will pulse near Modbus terminals when power is present. Verify the 12VDC to 24VDC is present on the power terminals as shown on the cover.
 - b. Verify all wires are firmly attached on both ends.
 - c. Verify the wires are connected to the correct terminals - see Wiring in the manual.
 - d. Verify the configured control method matches control signal.

- e. Check the value of the analog input in register 40026. If this register shows 0, the 4-20 mA may be wired backwards. Swap wire and attempt again.
3. Diagnostics show a Motor Stall - Travel Deviation Fault.
 - a. If the actuator can not move to its commanded position, the actuator will stop, without damage, and issue a Motor Stall - Travel Deviation Fault warning. When the command signal changes outside of the deadband (Modbus register 40053), it will attempt to move again.

Maintenance

The frequency of inspection and maintenance depends on the severity of the service conditions.

⚠ WARNING

Avoid personal injury from sudden release of process pressure or bursting of parts. Before performing any maintenance operations:

- Do not remove the actuator from the valve while the valve is still pressurized.
- Always wear protective gloves, clothing, and eyewear when performing any maintenance operations to avoid personal injury.
- Disconnect any operating lines providing air pressure, electric power, or a control signal to the actuator. Be sure the actuator cannot suddenly open or close the valve.
- Use bypass valves or completely shut off the process to isolate the valve from process pressure. Relieve process pressure on both sides of the valve. Drain the process media from both sides of the valve.
- Back plug away from seat to relieve spring compression.
- Use lock-out procedures to be sure that the above measures stay in effect while you work on the equipment.
- Check with your process or safety engineer for any additional measures that must be taken to protect against process media.

⚠ WARNING

For explosion-proof applications, ensure the actuator cover is properly bolted before applying power to the actuator. Personal injury or property damage may result from fire or explosion if power is applied to the actuator with the cover removed in a hazardous area.

For explosion-proof applications, install rigid metal conduit and a conduit seal no more than 457 mm (18 in) from the actuator. Personal injury or property damage may result from explosion if the seal is not installed.

Select wiring and/or cable glands that are rated for the environment of use (such as hazardous area, ingress protection, and temperature). Failure to use properly rated wiring and/or cable glands can result in personal injury or property damage from fire or explosion.

Wiring connections must be in accordance with local, regional, and national codes for any given hazardous area approval. Failure to follow the local, regional, and national codes could result in personal injury or property damage from fire or explosion.

Disassembly

1. Follow valve manufacturer's warnings and instructions for isolating and releasing line pressure prior to disassembling the valve.

2. Move the actuator off the seat before disassembling the valve and actuator.

NOTICE

The following steps are intended to prevent damage to the valve during the removal of the yoke and actuator.

3. For Positioning Actuators

- Command the valve to anywhere between 10% and 20% travel.
- Disconnect power and signal.
- Proceed to step 4.

For On/Off Actuators

- Command the valve to open or close, and cut the power when the valve is at mid-stroke.
- Disconnect power and signal.
- Proceed to step 4.

4. Remove actuator and mounting kit from the valve body.

Assembly

1. Connect actuator and mounting kit to valve body.
2. Replace the top of the explosion proof enclosure (key 60) and tighten cap screws (key 64) to 20 N • m (15 lbf • ft).

Figure 17. Fisher easy-Drive 200L Actuator Exploded View

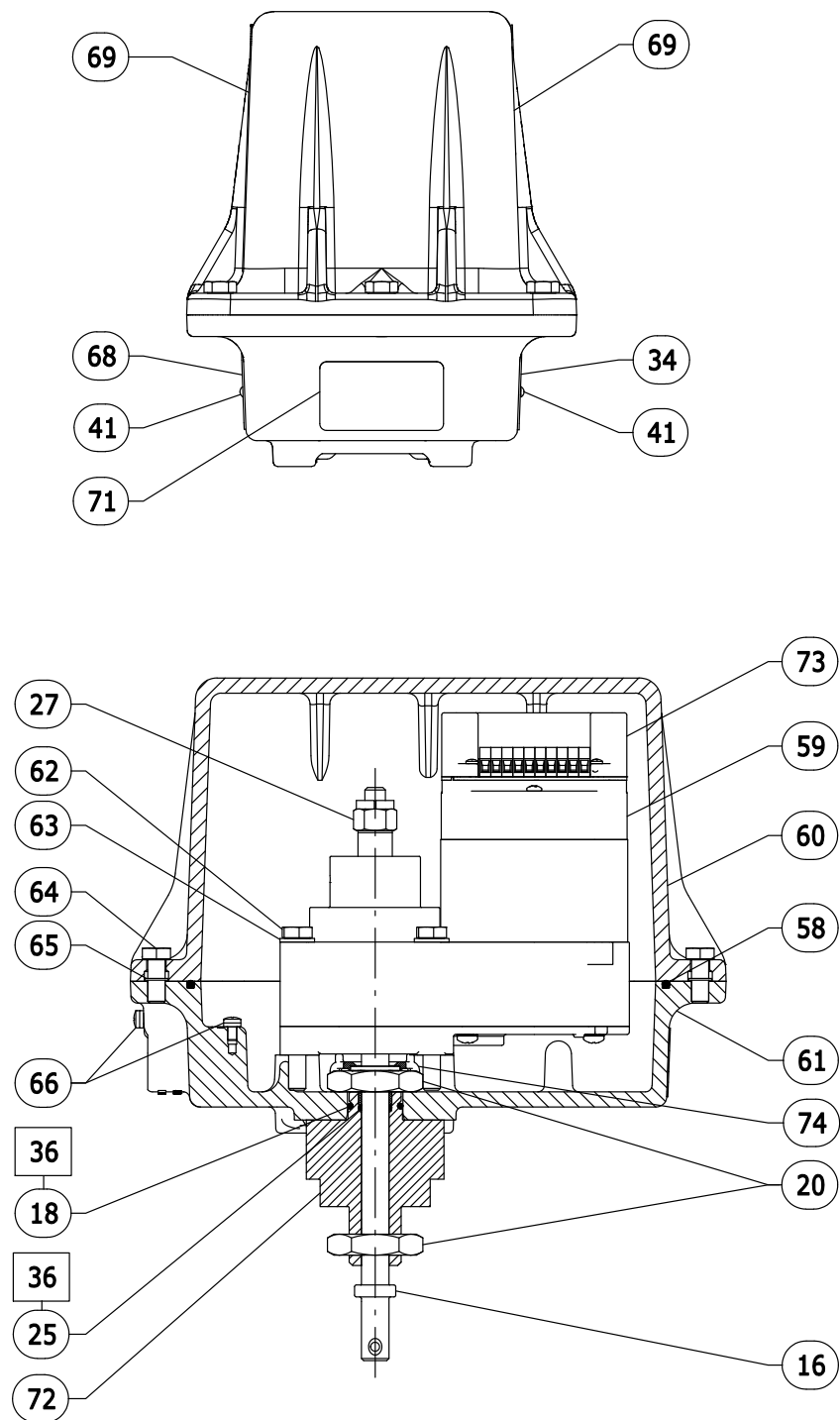

□ APPLY LUB

CE94736-A

Parts Ordering

Each easy-Drive 200L actuator is assigned a serial number, which can be found on the nameplate. Refer to the number when contacting your [Emerson sales office](#) for assistance or when ordering replacement parts.

⚠ WARNING

Use only genuine Fisher replacement parts. Components that are not supplied by Emerson should not, under any circumstances, be used in any Fisher actuator, because they may void your warranty, might adversely affect the performance of the actuator, and could cause personal injury and property damage.

Note

Previous generation gearboxes may not be compatible with the easy-Drive 200L. For additional information please consult your Emerson sales office.

Parts Kits

Board Replacement Kit (On/Off is default)	GE83055X012
Board Replacement Kit + Positioning License Dongle	GE83126X012
Motor/Gearbox Assembly	GE84237X012
Motor/Gearbox/Board Assembly (On/Off is default)	GE84238X012
Motor/Gearbox/Board Assembly + Positioning License Dongle	GE89047X012
Replacement Kit - Belleville Springs	GE78843X012
Positioning License Dongle (1 License)	GE83574X012
Positioning License Dongle (5 License)	GE83574X022

Parts List

Note

For part numbers not shown, contact your Emerson sales office.

Key	Description
-----	-------------

16	Stem
18	O-ring
20	Nut, Hex, Locking
25	O-ring
27	Nut, Hex Nylon Insert
34	Nameplate, easy-Drive 200L

Key	Description
36	Lubricant, Grease
41	Screw, Drive
58	O-ring
59	Motor/Gearbox
60	Upper Enclosure
61	Lower Enclosure
62	Screw Cap, Hex Hd
63	Washer, Plain
64	Screw Cap, Hex Hd
65	Retaining Washer
66	Retainer, Wire (Sem)
68	Certification Nameplate
69	Label, Cover
71	Label, HiPot
72	Yoke Assembly
73	Cover/Controller Board
74	Stop Assembly

Figure 18. Fisher easy-Drive 200L Actuator Assembly

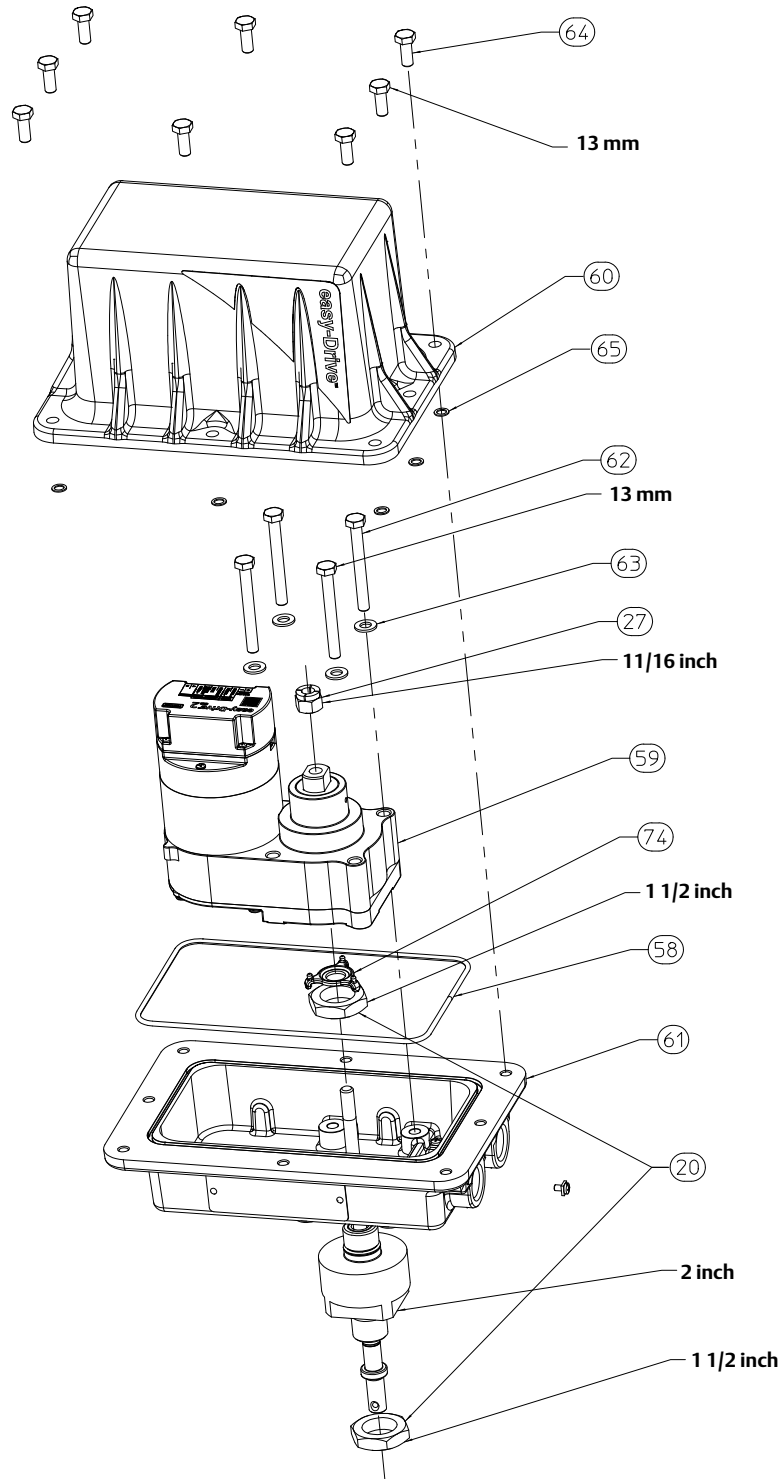

GE94736_ex

Appendix A - Modbus

A.1 Register Summary

Table 3. easy-Drive 200L Modbus Map

Type ⁽¹⁾	Name	MB Register	Default	R/W	Values	Notes
uint16	Modbus position command (100=10.0%)	40001	0	R/W	0-1000	Modbus command value with one implied decimal place (1000=100.0%). R/W at all times but only used in Modbus control mode. In on/off mode 0-499 will result in a move to 0% and 500-1000 will result in a move to 100%.
uint16	Digital output	40002	0	R/W	0,1	0=no voltage supplied to terminals, 1=voltage supplied to terminals (Only used when output setup is set for Remote controlled)
uint16	Reset error codes	40003	0	R/W	0,1	Value of 1 will clear faults. Will automatically set back to 0.
uint16	RESERVED	40004				
uint16	RESERVED	40005				
uint16	RESERVED	40006				
uint16	RESERVED	40007				
uint16	RESERVED	40008				
uint16	RESERVED	40009				
uint16	Actual position (100=10.0%)	40010	0	R	0-1000	Present position of the actuator relative to span with 1 implied decimal place (1000=100.0%). Valid for all control modes.
uint16	Commanded position (100=10.0%)	40011	0	R	0-1000	Present position command of the actuator relative to span (1000=100.0%). Valid for all control modes.
uint16	Diagnostic Flags	40012	0	R	0-65535	Bit flags - see chart
uint6	Digital status	40013	0	R	0 - 1	0=no connection between terminals, 1=connection between terminals (Status of digital input or output)
uint32	Total Running Time (min)	40014, 40015	0	R	4294967296	Total number of minutes the actuator has been powered on since time has been reset
uint32	Total Open Time (min)	40016, 40017	0	R	4294967296	Total number of minutes the actuator has been at 100% of travel since time has been reset
uint32	Total Closed Time (min)	40018, 40019	0	R	4294967296	Total number of minutes the actuator has been at 0% of travel since time has been reset
uint32	Number of Closed (cycle count)	40020, 40021	0	R	4294967296	Total number of close cycles the actuator has performed since reset. One open/close cycle counts as 1.
uint32	Number of Power Cycles	40022, 40023	0	R	4294967296	Total number of times the actuator has been powered on.
uint32	Number of Movements	40024, 40025	0	R	4294967296	Total number of movements the actuator has performed. Move must be at least 5% of rated travel for cycle to increment.
uint16	Analog input control value	40026	0	R	0-2400	Value of the analog signal in mA with 2 implied decimals. In analog control mode, this is the command value and is subject to the analog settings in registers 40046 to 40059. Always active but a slower refresh rate when unit is not in analog control mode.
uint16	Incoming voltage	40027	0	R	0-350	Diagnostic register - value of incoming voltage with 1 implied decimal.
uint16	Latch Open State	40028	0	R	0 - 1	Normally open latch state

-continued-

Table 3. easy-Drive 200L Modbus Map (cont.)

Type	Name	MB Register	Default	R/W	Values	Notes
uint16	Latch Close State	40029	0	R	0 - 1	Normally closed latch state
uint16	RESERVED	40030				
uint16	RESERVED	40031				
uint16	RESERVED	40032				
uint16	RESERVED	40033				
uint16	RESERVED	40034				
uint16	RESERVED	40035				
uint16	RESERVED	40036				
uint16	RESERVED	40037				
uint16	RESERVED	40038				
uint16	RESERVED	40039				
uint16	Test Register - 16 bit	40040	45964	R	45964	Fixed register to test correct reading of 16 bit registers - Hex=B38C, Binary=1011001110001100
uint32	Test Register - 32 bit	40041, 40042	3,012,341,331	R	3,012,341,331	Fixed register to test correct reading of 32 bit registers - Hex=B38C AE53, Binary=1011001110001100 1010111001010011
uint16	Span calibration	40043	0	R/W	0,1	Value of 1 will initiate span calibration. Will automatically set back to 0.
uint16	RESERVED	40044				
uint16	RESERVED	40045				
uint16	RESERVED	40046				
uint16	RESERVED	40047				
uint16	RESERVED	40048				
uint16	RESERVED	40049				
uint16	Loss of signal position (100=10.0%)	40050	0	R/W	0-1001	Position to which valve plug will be driven upon loss of signal. Loss of signal is based upon the active control mode. 0-1000=0-100.0% with 1 implied decimal point. In on/off mode 0-499 will result in movement to 0% while 500-1000 will result in movement to 100%. A value of 1001 in any control mode is the setting for "lock-in-last."
uint16	Modbus timeout(s)	40051	60	R/W	0-65535	Time without a valid Modbus message is seen (to any address) before "loss of signal" motion is engaged when in Modbus control mode. Only active in Modbus control mode. 0=disabled
uint16	Dual contact timeout(s)	40052	60	R/W	0-3600	Time without a digital signal being low (contact made) from either digital input as viewed by voltage level on the digital input terminals. If neither contact has been made (pulled input low) within the timeout period, the valve plug will be moved to the loss-of-signal position. Only active in the local, on-off, dual contact mode. 0=disabled.

-continued-

Table 3. easy-Drive 200L Modbus Map (cont.)

Type	Name	MB Register	Default	R/W	Values	Notes
uint16	Deadband (10=1.0%)	40053	5	R/W	0-250	Minimum percentage signal change to elicit a movement response based upon end position of last movement. For example, if the previous command resulted in the actuator moving to 31.2% of travel and deadband is set to 100 (10.0%), setpoint must command valve to 21.2% or 41.2% before valve will move to new position. Default is set set to minimize signal dithering.
uint16	Low travel cutoff position (100=10.0%)	40054	50	R/W	0-999	Analog input command, in percent with one implied decimal (50=5.0%), below this value will result in the valve plug moving to the closed position. Active in both local and Modbus control modes.
uint16	Analog on/off close position (100=10.0%)	40055	400	R/W	0-999	When the valve is in 4-20 mA on/off mode, this value is the point at which the valve will close. It must be set to a smaller value than the analog on/off open position. Percentage position value with one implied decimal (400=40.0%).
uint16	Analog on/off open position (100=10.0%)	40056	500	R/W	1-1000	When the valve is in 4-20 mA on/off mode, this value is the point at which the valve will open. It must be set to a larger value than the analog on/off close position. Percentage position value with one implied decimal (500=50.0%).
uint16	Analog Close Value	40057	40	R	31 - 220	The analog value, in mA with one implied decimal (40=4.0 mA), that defines the closed position
uint16	Analog Open Value	40058	200	R	31 - 220	The analog value, in mA with one implied decimal (200=20.0 mA), that defines the open position
uint16	Number of retries	40059	2	R/W	0-4	When the valve plug encounters an obstruction, how many attempts will it make to move past that point, assuming no change in the command signal within the deadband range
uint16	RESERVED	40060				
uint16	RESERVED	40061				
uint16	RESERVED	40062				
uint16	RESERVED	40063				
uint16	RESERVED	40064				
uint16	RESERVED	40065				
uint16	RESERVED	40066				
uint16	Control Source	40067	0	R/W	0-5	0=Dual Contact On/Off 1=Single Contact On/Off, 2=Modbus On/Off, 3=Modbus Positioning, 4=4-20 Positioning, 5=4-20 Level
uint16	Valve Type	40068	1	R/W	1-10	1=D3, 2=D4, 3=easy-Drive Actuator 0.62", 4=easy-Drive Actuator 0.75", 5 = easy-Drive Actuator Stop-to-Stop, 6 = easy-Drive Actuator 0.50"
uint16	RESERVED	40069				
uint16	RESERVED	40070				
uint16	RESERVED	40071				
uint16	RESERVED	40072				
uint16	RESERVED	40073				

-continued-

Table 3. easy-Drive 200L Modbus Map (cont.)

Type	Name	MB Register	Default	R/W	Values	Notes
uint16	Modbus address	40074	1	R/W	1-247	Slave Address of the actuator
uint16	Baud Rate	40075	5	R/W	4,5,6,7	4=4800 baud, 5=9600 baud (default), 6=19200 baud, 7=38400 baud
uint16	Parity	40076	0	R/W	0,1,2	0=Even, 1=Odd, 2=None
uint16	Modbus stop bits	40077	1	R/W	0,1,2	1 stop bit is the standard with even and odd parity while 2 stop bits is the standard for none.
uint16	MSB/LSB	40078	0	R/W	0,1	0=MSB (Big Endian), 1=LSB (Little Endian)
uint16	RESERVED	40079				
uint16	Digital I/O selection	40080	1	R/W	0,1	0=9 V sinking digital input, 1=25 mA at 10 V digital output
uint16	Digital I/O output setup	40081	0	R/W	0,1,2,3	Valid only when Digital I/O selection is set to Output (1) - 0=In position, 1=Fully closed, 2=Fully open, 3 = Remote controlled (driven by Digital Output register)
uint16	Digital I/O input setup	40082	0	R/W	0,1	Valid only when Digital I/O selection is set to Input (0) - 0=Reference only (status appears in 40013 and does nothing else), 1=Override (status appears in 40013 and valve plug is moved to safe position noted in register 40050)
uint16	RESERVED	40083				
uint16	RESERVED	40084				
uint16	RESERVED	40085				
uint16	RESERVED	40086				
uint16	RESERVED	40087				
uint16	RESERVED	40088				
uint16	RESERVED	40089				
uint16	RESERVED	40090				
uint16	RESERVED	40091				
uint16	RESERVED	40092				
uint16	RESERVED	40093				
uint32	Device Tag	40094-40113	Default tag name	R/W	0 - 255 per character	Device Tag (20 character UTF8 string)
uint32	Valve serial number	40114, 40115	0	R/W*	0-4,294,967, 296	Valve assembly serial number assigned at Fisher assembly plant
uint32	Motor serial number	40116, 40117	0	R/W*	0-4,294,967, 296	Motor/gearbox serial number
uint32	Motor revision	40118, 40119	0	R/W*	0-4,294,967, 296	Motor/gearbox revision
uint32	PCB serial number	40120, 40121	0	R/W*	0-4,294,967, 296	PCB serial number
uint16	PCB revision	40122, 40123	0	R/W*	0-4,294,967, 296	PCB revision
uint16	Flash Firmware major revision	40124	0	R	0-65535	From flash firmware when compiled
uint16	Flash Firmware minor revision	40125	0	R	0-65535	From flash firmware when compiled
uint16	Flash Firmware mod revision	40126	0	R	0-65535	From flash firmware when compiled
uint16	Flash Firmware build revision	40127	0	R	0-65535	From flash firmware when compiled
uint16	Boot Firmware major revision	40128	0	R	0-65535	From boot firmware when compiled
uint16	Boot Firmware minor revision	40129	0	R	0-65535	From boot firmware when compiled
uint16	Boot Firmware mod revision	40130	0	R	0-65535	From boot firmware when compiled
uint16	Boot Firmware build revision	40131	0	R	0-65535	From boot firmware when compiled

-continued-

Table 3. easy-Drive 200L Modbus Map (cont.)

Type	Name	MB Register	Default	R/W	Values	Notes
uint32	PCB test date	40132, 40133	0	R/W*	0-4,294,967, 296	Seconds since January 1, 2000, Board Supplier Functional Test Date
uint32	Motor test date	40134, 40135	0	R/W*	0-4,294,967, 296	Seconds since January 1, 2000, Motor Supplier Test Date
uint32	System completion date	40136, 40137	0	R/W*	0-4,294,967, 296	Seconds since January 1, 2000, Final Assembly Test Date

1. uint is defined as unsigned integer
 uint16 – unsigned 16 bit variable, can take value 0-65535.
 uint32 – unsigned 32 bit variable, can take value 0-4294967295.
 (Reserved) – registers used for development use only.

† - 32bit register contains data that spans two registers – reads and write of data needs to be performed within the same Modbus command function to ensure coherency of data.

Table 4. Diagnostic Fault Flags

Hex Value	Bit Mask	Description	Value	Bit	Definition
0x8000	1000 0000 0000 0000	Fault in N.V. Memory – system has restored default settings	32768	15	A memory fault has occurred and the actuator has been restored to factory defaults. Contact your Emerson sales office .
0x8000	1000 0000 0000 0000	Fault in N.V. Memory – system has restored default settings	32768	15	A memory fault has occurred and the actuator has been restored to factory defaults. Contact your Emerson sales office.
0x4000	0100 0000 0000 0000	Motor Assembly Stall - Travel Deviation	16384	14	The actuator is unable to move to the commanded position and has stopped. Follow troubleshooting guide in Help section to remedy.
0x2000	0010 0000 0000 0000	Discrete Input override mode active	8192	13	The digital input has detected a closed contact and the actuator has moved to its safe position. Check switch input device status.
0x1000	0001 0000 0000 0000	System or Watchdog fault	4096	12	The actuator has experienced a fatal error and shut down. Contact your Emerson sales office.
0x0800	0000 1000 0000 0000	Analog Input calibration value not in expected range	2048	11	The analog values entered do not match the analog signal level. Check analog signal value and value entered.
0x0400	0000 0100 0000 0000	Valve travel distance calibration not in legal range	1024	10	The valve travel distance is outside the acceptable range. Confirm valve type and that no obstructions are present.
0x0200	0000 0010 0000 0000	Analog Input span calibration not in legal range	512	9	The analog values for open and close are less than 4 mA and previous values have been maintained. Calibrate analog input with differential >4 mA.
0x0100	0000 0001 0000 0000		256	8	
0x0080	0000 0000 1000 0000	Valve was shutdown while moving	128	7	Actuator was powered down during a move and actual position may vary from commanded. Recalibrate the valve span.
0x0040	0000 0000 0100 0000	Valve span calibrated (informational)	64	6	Span has been calibrated and actuator is ready.
0x0020	0000 0000 0010 0000	Valve position controller active (informational)	32	5	Actuator is active and ready.
0x0010	0000 0000 0001 0000	Loss of signal active	16	4	Control signal not present. Signal is <3 mA, timeout period exceeded (40051 or 40052).
0x0008	0000 0000 0000 1000		8	3	
0x0004	0000 0000 0000 0100	Modbus command has been sent (starts a calibrated system)	4	2	The actuator is successfully moving the valve.
0x0002	0000 0000 0000 0010	Analog input initialized (system has seen input >3 mA/1 V)	2	1	4-20 mA analog input has a valid signal present.
0x0001	0000 0000 0000 0001	Start delay active (within 15 second calibration window)	1	0	Span calibration using physical inputs allowed during startup.

Appendix B - Certificate of Conformance

	
<h3>EU Declaration of Conformity</h3>	
We, the manufacturer,	
Emerson Fisher Controls International LLC 205 South Center Street Marshalltown, Iowa 50158 USA	
declare under our sole responsibility that the following product(s);	
Electric Actuator easy-Drive	
to which this declaration relates, is in conformity with the provisions of the following European Community Directives, including the latest amendments, as shown in the attached schedule.	
Assumption of conformity is based on the application of the harmonized standards and, when applicable or required, a European Community Notified Body certification, as shown in the attached schedule.	
	
_____ Bob Stahlin Vice President-Sliding Stem Valve Business Unit Marshalltown, Iowa 50158	
_____ 3-August-2020 Date	
European Contact Emerson Group Services SAS Rue Paul-Baudry B.P. 10150 68701 Cernay Cedex France	
EDOCS ID: FCS_55	Page 1 of 2

Appendix B - Certificate of Conformance (cont.)

EMC Directive – 2014/30/EU

Models: All
EN 61326-1:2013

RoHS Directive – 2011/65/EU

Declaration of Exclusion

Models: All

The above equipment is excluded from the scope of this directive per Article 2, Paragraph 4, part C. Therefore the equipment cannot bear the CE mark related to RoHS compliance. However, the equipment may bear the CE mark to indicate compliance with other applicable EU directives.

ATEX Directive – 2014/34/EU (Applicable only if this mark appears on the product)

Certificate – **SIRA12ATEX1168X – Group II Category 2 G – Flameproof**
easy-Drive
Ex db IIA T6(Ta ≤ 70°C) Gb
Standards used: EN60079-0:2012/A11:2013, EN60079-1:2014

ATEX Notified Body for EC-Type Examination Certificate(s)

CSA Group Netherlands B.V. – Notified Body Number: 2813
Utrechtseweg 310, Building B42
6812AR Arnhem
The Netherlands

ATEX Notified Body for Quality Assurance

SGS Fimko Oy – Notified Body Number: 0598
P.O. Box 30 (Särkiniementie 3)
Helsinki, 00211
Finland

Neither Emerson, nor any of its affiliated entities assume responsibility for the selection, use or maintenance of any product. Responsibility for proper selection, use, and maintenance of any product remains solely with the purchaser and end user.

Fisher and easy-Drive are marks owned by one of the companies in the Emerson business unit of Emerson Electric Co. Emerson and the Emerson logo are trademarks and service marks of Emerson Electric Co. All other marks are the property of their respective owners.

The contents of this publication are presented for informational purposes only, and while every effort has been made to ensure their accuracy, they are not to be construed as warranties or guarantees, express or implied, regarding the products or services described herein or their use or applicability. All sales are governed by our terms and conditions, which are available upon request. We reserve the right to modify or improve the designs or specifications of such products at any time without notice.

Emerson

Marshalltown, Iowa 50158 USA

Sorocaba, 18087 Brazil

Cernay, 68700 France

Dubai, United Arab Emirates

Singapore 128461 Singapore

www.Fisher.com

