

# Service Instructions for Fisher™ 1068 Rotary Vane Actuator

This instruction manual was prepared by Kinetrol.

Do not install, operate or maintain this product without being fully trained and qualified in valve, actuator and accessory installation, operation and maintenance.



To avoid personal injury or property damage it is important to carefully read, understand, and follow all of the contents of this manual, including all safety cautions and warnings.

If you have any questions about these instructions, contact your [Emerson sales office](#) before proceeding.

---

## Fisher 1068 Rotary Vane Actuator



X1591

**SPRING RETURN**



X1590

**DOUBLE ACTING**

---

## Installation

### ⚠ WARNING

Always wear protective gloves, clothing, and eyewear when performing any installation operations. Check with your process or safety engineer for any other hazards that may be present from exposure to process media.

### ⚠ WARNING

To avoid personal injury and parts damage, do not apply pressure that exceeds the Maximum Operating Pressure of 7 bar (100 psig). Use pressure-limiting or pressure-relieving devices to prevent the Operating Pressure from exceeding this value.

## Actuator Mounting

### ⚠ WARNING

Avoid personal injury or property damage from sudden release of process pressure or bursting of parts. Before performing any maintenance operations:

- Do not remove the actuator from the valve while the valve is still pressurized.
- Always wear protective gloves, clothing, and eyewear when performing any maintenance operations.
- Disconnect any operating lines providing air pressure, electric power, or a control signal to the actuator. Be sure the actuator cannot suddenly open or close the valve.
- Use bypass valves or completely shut off the process to isolate the valve from process pressure. Relieve process pressure from both sides of the valve. Drain the process media from both sides of the valve.
- Safely vent the power actuator loading pressure.
- Use lock-out procedures to be sure the above measures stay in effect with you work on the equipment.
- The valve packing box may contain process fluids that are pressurized, even with the valve has been removed from the pipeline. Process fluids may spray out under pressure when removing the packing hardware or packing rings.
- Check with your process or safety engineer for any other hazards that may be present from exposure to process media.

### NOTICE

When adjusting the travel stop for the closed position of the valve ball or disk, refer to the appropriate valve instruction manual for detailed procedures. Undertravel or overtravel at the closed position may result in poor valve performance and/or damage to the equipment.

Neither Emerson, nor any of its affiliated entities assume responsibility for the selection, use or maintenance of any product. Responsibility for proper selection, use, and maintenance of any product remains solely with the purchaser and end user.

Fisher is a mark owned by one of the companies in the Emerson business unit of Emerson Electric Co. Emerson and the Emerson logo are trademarks and service marks of Emerson Electric Co. All other marks are the property of their respective owners.

The contents of this publication are presented for informational purposes only, and while every effort has been made to ensure their accuracy, they are not to be construed as warranties or guarantees, express or implied, regarding the products or services described herein or their use or applicability. All sales are governed by our terms and conditions, which are available upon request. We reserve the right to modify or improve the designs or specifications of such products at any time without notice.

Emerson  
Marshalltown, Iowa 50158 USA  
Sorocaba, 18087 Brazil  
Cernay, 68700 France  
Dubai, United Arab Emirates  
Singapore 128461 Singapore

[www.Fisher.com](http://www.Fisher.com)



Installation, Operation & Maintenance Instructions Fisher 1068 series (Models 5i-15i)  
**ROTARY 1/4 TURN PNEUMATIC ACTUATORS**  
Suitable for use in safe area and hazardous gas/dust atmospheres (ATEX)

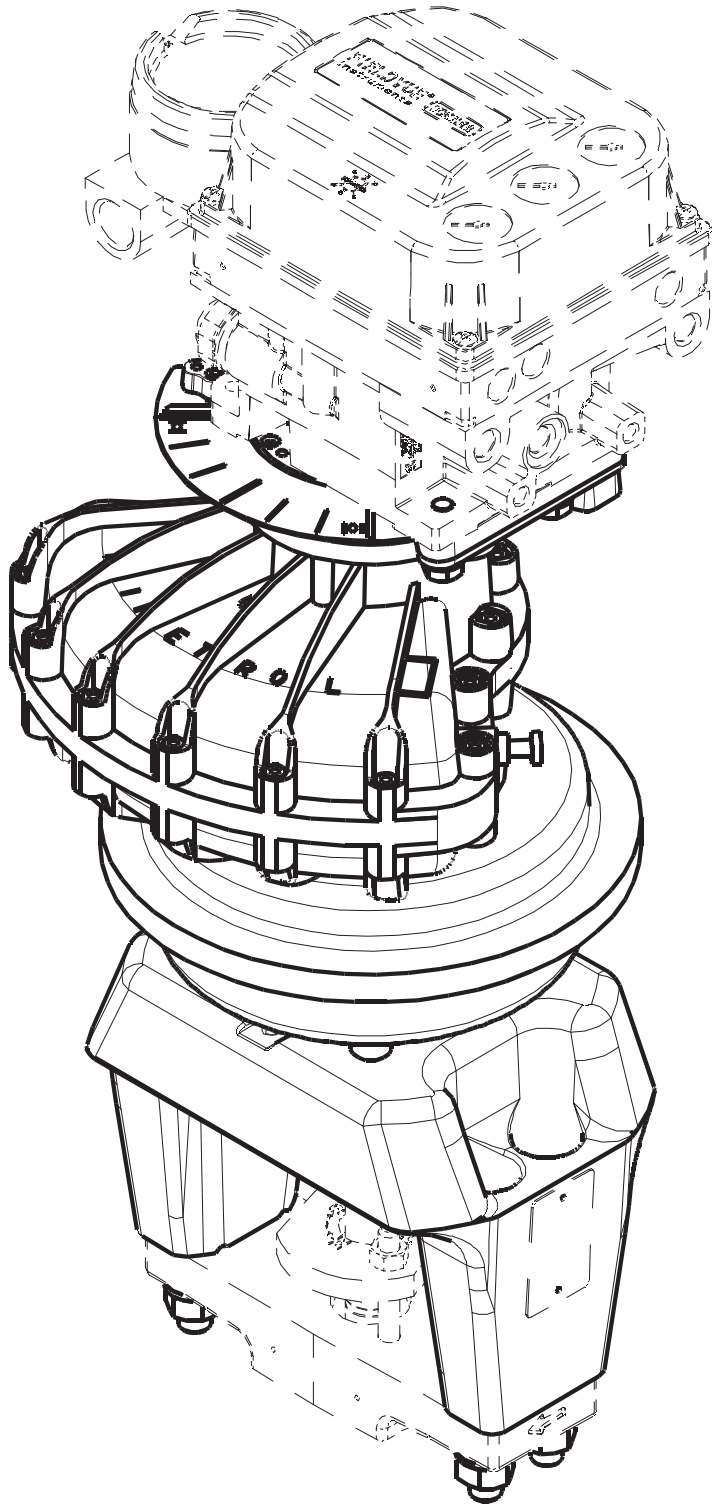

Issue	Signed	Date
G	D.G.W	08-01-20

**KINETROL** Trading Estate Farnham Surrey England

Doc.No. TD202
Page 1 of 18

**Installation, Operation & Maintenance Instructions Fisher 1068 series (Models 5i-15i)**  
**ROTARY 1/4 TURN PNEUMATIC ACTUATORS**  
**Suitable for use in safe area and hazardous gas/dust atmospheres (ATEX)**

**Table of Contents**

Section 1: Rotary ¼ turn actuator / double acting & spring return models.

1.1 General Actuators & Spring Returns

- 1.1.1 Mounting Holes sizes
- 1.1.2 Mounting
- 1.1.3 Drive Coupling
- 1.1.4 Air / Gas Supply
- 1.1.5 Operation
- 1.1.6 Maintenance
- 1.1.7 Recommended Spare Parts
- 1.1.8 Labelling
- 1.1.9 Adjustment

1.2 Actuator Seal Replacement Instructions

- 1.2.1 Dismantling Actuator
- 1.2.2 Re-assembling Vane
- 1.2.3 Re-assembling Actuator
- 1.2.4 Exploded view of typical Actuator

1.3 Spring Return Units

- 1.3.1 Removal of Spring Return Unit
- 1.3.2 Re-fitting of Spring Return Unit

Section 2: Accessory mount for Fisher DVC2000 & DVC6200 Positioners

- 2.1.1 Mount kit for Fisher DVC Positioners
- 2.1.2 Accessory mount plate for size 12i/14i/15i Actuators

Section 3: Installation of Valve Yokes and anti-backlash couplings

- 3.1.1 Fitting anti-backlash couplings to Spring Return actuators
- 3.1.2 Mounting Yokes to Actuators & Spring Returns
- 3.1.3 Mounting Yokes to valves

**Installation, Operation & Maintenance Instructions Fisher 1068 series (Models 5i-15i)  
 ROTARY 1/4 TURN PNEUMATIC ACTUATORS  
 Suitable for use in safe area and hazardous gas/dust atmospheres (ATEX)**

**Section 1: Rotary 1/4 turn actuator / double acting & spring return models.**

**1.1 General Actuators & Spring Returns**

**1.1.1 Mounting Holes sizes**

**Table 1: Actuator (ANSI Threads)**

Model	Number of Holes	ANSI Thread	Depth of Thread	PCD
7i	4	5/16-18 UNC	0.63"	2.00"
8i	4	5/16-18 UNC	0.63"	2.76"
9i	4	3/8-16 UNC	0.79"	2.56"
10i	4	3/8-16 UNC	0.63"	4.02"
12i	4	1/2-13 UNC	0.94"	3.06"
14i	4	5/8-11 UNC	1.12"	3.89"
15i	4	5/8-11 UNC	1.12"	5.51"

**Table 2: Spring Return (ANSI Threads)**

Model	Number of Holes	ANSI Thread	Depth of Thread	PCD
5i	4	5/16-18 UNC	0.51"	2.76"
7i	4	5/16-18 UNC	0.51"	2.76"
8i	4	5/16-18 UNC	0.63"	2.76"
9i	4	3/8-16 UNC	0.63"	4.02"
10i	4	3/8-16 UNC	0.63"	4.02"
12i	4	3/8-16 UNC	0.63"	4.02"
14i	4	1/2-13 UNC	0.94"	4.92"
15i	4	5/8-11 UNC	1.12"	5.51"

**1.1.2 Mounting**

Actuator / spring and driven unit must be correctly aligned, i.e. actuator vane / spring coupling and driven unit must be able to move in same direction from end stop when coupled together.

**Figure 1.**

Vane shown in mid-travel position.  
 Identifying groove in top of output drive square shows position of vane.

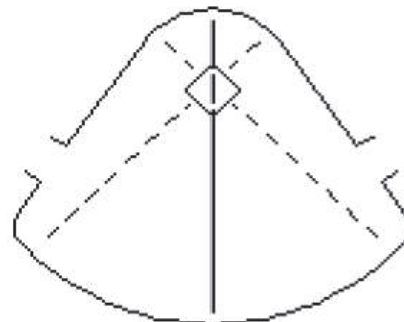

**Installation, Operation & Maintenance Instructions Fisher 1068 series (Models 5i-15i)**  
**ROTARY 1/4 TURN PNEUMATIC ACTUATORS**  
**Suitable for use in safe area and hazardous gas/dust atmospheres (ATEX)**

Note: Position of output shaft when vane at mid-travel position.

- 1) Take particular care in aligning model 5i actuator, 6-hole mounting means 30° misalignment possible if flange has 60° error and coupling 90° error.
- 2) There must be no end load on actuator drive shaft.
- 3) Check clearance between actuator and driven unit drive shaft, allowing for coupling to be used.
- 4) Care must be taken to ensure concentricity between actuator or spring return drive shaft and driven unit shaft.
- 5) Actuator can be mounted in any plane.
- 6) When side loading of actuator shaft is unavoidable, ensure load does not exceed guide lines given in Kinetrol Technical data sheet TD28.

### **1.1.3 Drive Coupling**

- 1) Square hole drive coupling supplied for double acting actuators and anti-backlash drive coupling supplied with spring return actuators both in stainless steel.
- 2) In order to prevent rubbing and wear on the actuator / spring mount face, the actuator square should engage as deeply as reasonably practical into the coupling. However, a minimum gap of 0.5mm (0.02") between the coupling face and actuator / spring mount face should be maintained.

### **1.1.4 Air/Gas Supply**

- 1) Operating air pressure should not exceed 7 bar (100 psi).
- 2) Supply medium must be clean, dry, oil-free, and non-corrosive and meet the requirements of ISA standard 7.0.01 or ISO 8573-1. Severe personal injury or property damage may occur from an uncontrolled process if the instrument supply medium is not clean, dry, oil-free, and non-corrosive. While use and regular maintenance of a filter that removes particles larger than 40 micrometers in diameter will suffice in most applications, further filtration down to 5 micrometer particle size is recommended. Lubricant content is not to exceed 1 ppm weight (w/w) or volume (v/v) basis. Condensation in the air supply should be minimised.
- 3) Plastic or other non-conductive tubing should not be used if unit is ATEX.
- 4) The actuator can be driven by a hazardous gas as long as the gas is not corrosive (e.g. natural gas "sweet" and not "sour" gas is used).
- 5) The actuator shall not be operated with flammable gas/air mixtures.
- 6) Air can be passed to the actuator from three different sets of air ports:
  - a) Through the side holes.
  - b) Through the two holes at the rear of the actuator by fitting a Namur adaptor.
  - c) Through the two holes in the top flange of the actuator.

Issue	Signed	Date	<b>KINETROL</b> Trading Estate Farnham Surrey England	Doc.No. TD202
G	D.G.W	08-01-20		Page 4 of 18

**Installation, Operation & Maintenance Instructions Fisher 1068 series (Models 5i-15i)**  
**ROTARY 1/4 TURN PNEUMATIC ACTUATORS**  
**Suitable for use in safe area and hazardous gas/dust atmospheres (ATEX)**

**1.1.5 Operation**

- 1) External stops are strongly recommended when actuator is operating a mechanism with cantilevered load. However, Kinetrol technical data sheet, TD37, can be used to ensure load inertia and travel speed remain within allowable limits.
- 2) Positioner end of drive shaft may be used for visual position indication, when indicator arrow fitted.
- 3) Spring units can only be fitted to the driven (square) end of the actuator.
- 4) Ambient operating temperature range of actuator and spring is -40°C to 80°C as standard and -54°C to 60°C with low temperature seals.  
 Special care should be taken to ensure that heat conducted from, for example, a hot valve, does not increase the temperature above these limits.  
 Refer to Kinetrol for guidance.
- 5) Ensure environmental conditions, such as corrosive environments, are compatible with the materials of construction and protective finishes (Kinetrol technical data sheet TD14 refers). If unsure, contact Kinetrol.  
 Excessive corrosion of the actuator and spring may cause it to fail in service.
- 6) The maximum rubbing speed of any component within the actuator and spring return unit must not exceed 4m/s for Cat 2.  
 See table below for minimum operating travel times:
- 7) Do not allow dust layers to build up on the apparatus.

**Table 3: Minimum Actuator operating travel times**

Model	Category 2 operating time for 90° travel (sec)
5i	0.027
7i	0.036
8i	0.042
9i	0.046
10i	0.047
12i	0.060
14i	0.081
15i	0.091

**Installation, Operation & Maintenance Instructions Fisher 1068 series (Models 5i-15i)**  
**ROTARY 1/4 TURN PNEUMATIC ACTUATORS**  
 Suitable for use in safe area and hazardous gas/dust atmospheres (ATEX)

**1.1.6 Maintenance**

- 1) Actuator maintenance is limited to replacement of seals when wear affects actuator performance.
- 2) Seal life will vary according to application, conditions of cycle frequency, temperature, condition of air supply, etc.
- 3) Detailed seal replacement instructions in next section.
- 4) Spring return units are not user serviceable and therefore no spare parts are available other than complete units, baseplate gasket / O-ring seals and keeper plates for safe spring removal.

**1.1.7 Recommended Spare Parts**

- 1) Standard seal kits, available for each actuator model, consist of the following:
  - 2 off vane seal            - 2 off expander            - 2 off shaft seal
  - Plus all necessary O-rings, screws, nuts and grease for all sizes.
 In addition, a tube of sealant will be required to seal case halves.

**Table 4: Standard seal kit spare part ordering codes**

Model	Act Seal Kit P/N	Vane P/N	Baseplate Seal P/N
5i	R1068KTX012	R1068KTX132	R1068KTX262
7i	R1068KTX022	R1068KTX142	R1068KTX272
8i	R1068KTX032	R1068KTX152	R1068KTX282
9i	R1068KTX042	R1068KTX162	R1068KTX292
10i	R1068KTX052	R1068KTX172	R1068KTX302
12i	R1068KTX062	R1068KTX182	R1068KTX312
14i	R1068KTX072	R1068KTX192	R1068KTX322
15i	R1068KTX082	R1068KTX202	R1068KTX332

**1.1.8 Labelling**

- 1) All Kinetrol actuators and spring return units that are approved for use in areas where explosives, dust and gases are present, are marked with the following labels:

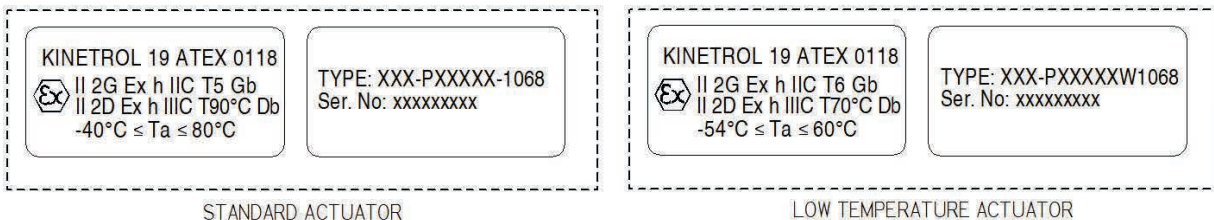

- 2) Ensure that the details on the label such as the ambient temperature range is suitable for the application. Also ensure that any other equipment fitted to the actuator and spring return unit (e.g.valve or positioner) does not restrict the use within the parameters shown on the above labels.



**Installation, Operation & Maintenance Instructions Fisher 1068 series (Models 5i-15i)  
 ROTARY 1/4 TURN PNEUMATIC ACTUATORS  
 Suitable for use in safe area and hazardous gas/dust atmospheres (ATEX)**

**1.1.9 Adjustment**

1) Kinetrol Actuators come as standard with adjustable end stops.

**Table 5: Standard stroke adjustments available**

Models	Adjustment range available
5i/7i/8i/9i/14i/15i	10°
10i/12i	11°

2) Greater adjustment range possible with non-standard stops.  
 Contact Kinetrol for details.

**1.2 Actuator Seal Replacement Instructions**

**1.2.1 Dismantling Actuator**

- 1) DISMANTLING ACTUATOR (see exploded view Figure 3)  
 CAUTION: Before dismantling, check there are no burrs on square drive shafts. If there are, remove to avoid damage to bearings and shaft seals during removal of case halves. In the case of spring return actuators, remove spring unit (according to section 1.3.1) before opening actuator case. Ancillary equipment such as DVC mount plate / Yoke / coupling etc, will also need to be removed before dismantling actuator.
- 2) All models: loosen, but do not remove, all case screws.
- 3) Separate case halves by connecting air to inlet port and apply pressure to drive them apart. Procedure is safe although the separation is audible, ear defenders are recommended.  
 Pull off one case half.  
 CAUTION: Do NOT hammer diecast castings or shaft end. It will damage internal sealing surfaces.
- 4) Clean both case halves removing silicone rubber sealant.  
 Clean joint surfaces of case flange with surgical spirit.
- 5) Replace and lubricate shaft seals.
- 6) Undo vane nuts and bolts and remove old expanders and seals from vane. Take care not to damage side plates.
- 7) Clean vane.

**Installation, Operation & Maintenance Instructions Fisher 1068 series (Models 5i-15i)  
 ROTARY 1/4 TURN PNEUMATIC ACTUATORS  
 Suitable for use in safe area and hazardous gas/dust atmospheres (ATEX)**

**1.2.2 Re-assembling vane**

- 1) Check vane for any obvious defects and make sure it is free of burrs, then place vane face down on a bench or hold in a vice.
- 2) Fit Side plate Infill Insert into Side plates (7i only). Push hex headed bolts with plain washer through side plate, expander (teeth facing towards head of bolt) and seal (base of seal away from bolt head).
- 3) After checking that expander and seal are the right way round - expander has vane shaped hole, seal has shaft centre line marked.
- 4) While holding up side plate, expander and seal, apply a low strength anaerobic adhesive to bolt thread such as Loctite 222.
- 5) Thread first few threads of each bolt into vane.
- 6) Screw bolts down and tighten to torques given in table 6.
- 7) Turn vane over then fit seal, expander and side plate over end of bolts. Check orientation as before.
- 8) Screw nuts down thread.
- 9) Hold head of bolt with a spanner, torque up nuts to torque specified in table 6.

**Table 6: Vane bolt and nut Tightening Torques**

Model	Tightening Torque	
5i	8lbf.ins	0.90 Nm
7i	8lbf.ins	0.90 Nm
8i	20lbf.ins	2.26 Nm
9i	20lbf.ins	2.26 Nm
10i	15lbf.ins	1.70 Nm
12i	30lbf.ins	3.39 Nm
14i	30lbf.ins	3.39 Nm
15i	30lbf.ins	3.39 Nm

**1.2.3 Re-assembling Actuator**

- 1) Coat bearing bushes and inside both case halves with molybdenum disulphide grease or grease supplied by Kinetrol (usually as part of seal kit).
- 2) Lightly and evenly coat joint face on each case half with instant gasket sealant available from Kinetrol or Silastic 732 RTV sealant obtainable from ironmongers, etc. may be used as a substitute.  
 CAUTION: EXCESS SEALANT, if extruded inside case, WILL IMPAIR OPERATION OF SEALS.  
 Remove all excess sealant especially from inside edge.
- 3) Insert vane into one case half, turning it to ease square on drive shaft through shaft seal. Watch that lip seals at ends of vane easily work down into case without damage.
- 4) Fit remaining case half on top of the other, turning it to ease positioner shaft through shaft seal.
- 5) CAUTION: Check that lip seals are not trapped at case joint face. Ensure minimal time delay to closing of case once sealant has been applied.
- 6) Tighten case bolts to torques given in table 7.

**Installation, Operation & Maintenance Instructions Fisher 1068 series (Models 5i-15i)**  
**ROTARY 1/4 TURN PNEUMATIC ACTUATORS**  
 Suitable for use in safe area and hazardous gas/dust atmospheres (ATEX)

**Table 7: Case bolt Tightening Torques**

Model	Tightening Torque	
5i	20lbf.ins	2.26 Nm
7i	20lbf.ins	2.26 Nm
8i	60lbf.ins	6.78 Nm
9i	60lbf.ins	6.78 Nm
10i	80lbf.ins	8.96 Nm
12i	100lbf.ins	11.3 Nm
14i	120lbf.ins	13.6 Nm
15i	225lbf.ins	25.4 Nm

- 7) Rotate vane manually to check movement and wipe away sealant extruded internally.
- 8) Allow setting time for sealant before applying test air pressure.

**Figure 3. Exploded view of typical actuator**

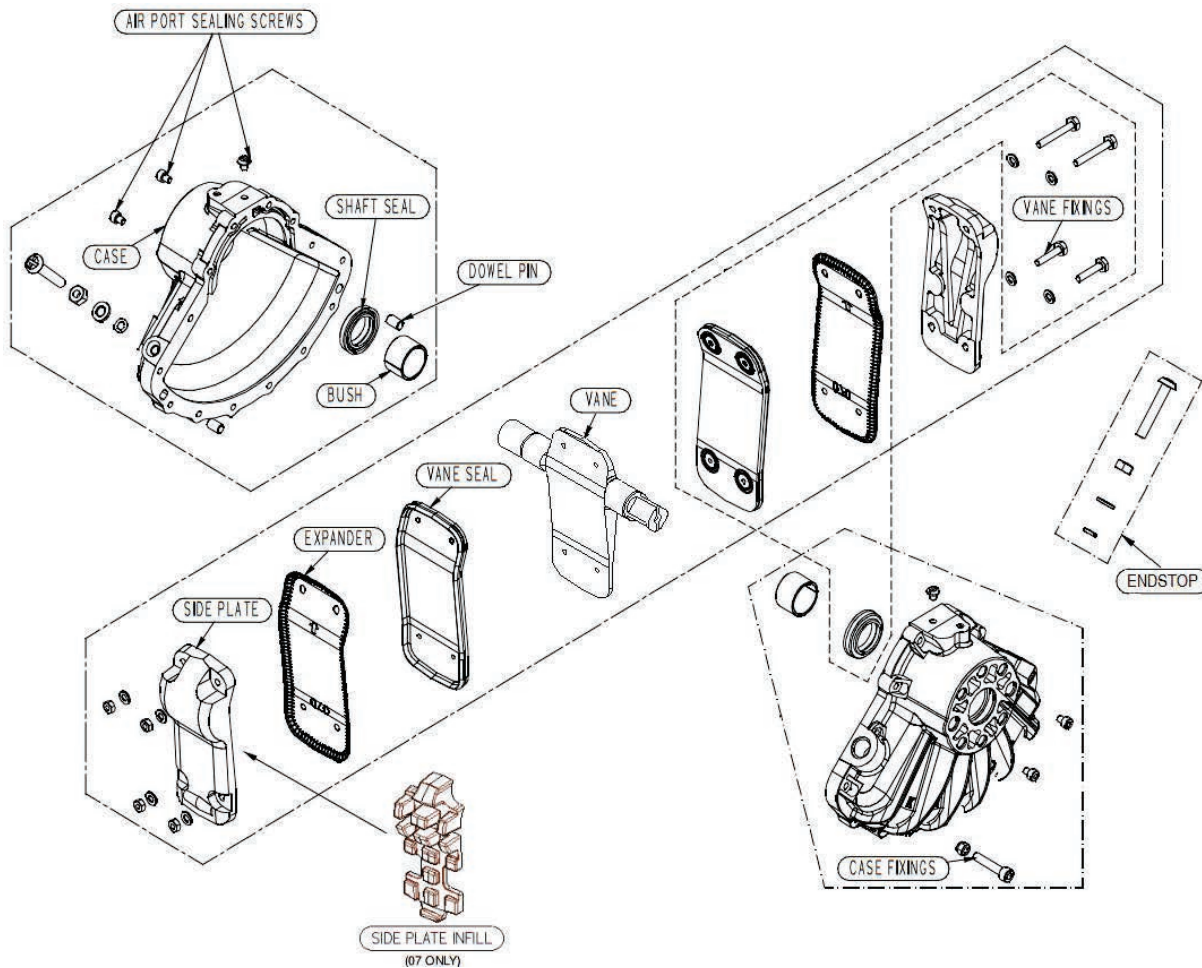

**Installation, Operation & Maintenance Instructions Fisher 1068 series (Models 5i-15i)**  
**ROTARY 1/4 TURN PNEUMATIC ACTUATORS**  
 Suitable for use in safe area and hazardous gas/dust atmospheres (ATEX)

**1.3 Spring Return Units**

**1.3.1 Removal of spring return unit**

- 1) **WARNING** – the wound-up steel springs are storing a large amount of energy which, if suddenly released, can be dangerous.
- 2) A keeper plate strong enough to take full spring torque must be fitted in order to remove S/R unit without releasing spring tension.
- 3) Keeper plates and screws available from Kinetrol.  
 Refer to table 8 for spare part order Numbers.

**Table 8: Keeper plate ordering codes**

Model	Part Number
5i	GE98028X012
7i	GE98028X022
8i	GE98028X032
9i	GE98028X042
10i	GE98028X052
12i	GE98028X062
14i	GE98028X072
15i	GE98028X082

**Figure 4. Typical spring return actuator**

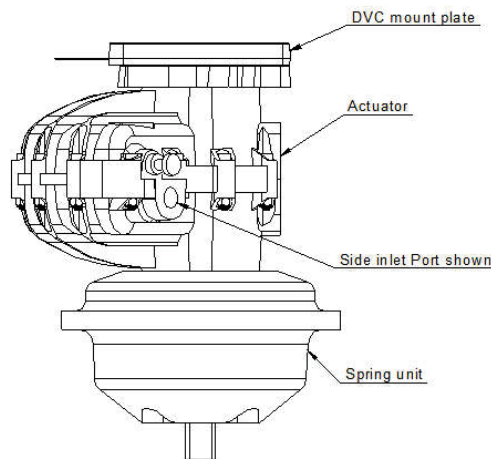

- 4) If the spring return actuator is installed as shown in figure 4, it will first be necessary to invert the assembly before removing or refitting the spring unit. (as shown in figure 5)

**Installation, Operation & Maintenance Instructions Fisher 1068 series (Models 5i-15i)**  
**ROTARY 1/4 TURN PNEUMATIC ACTUATORS**  
**Suitable for use in safe area and hazardous gas/dust atmospheres (ATEX)**

- 5) Connect air line via pressure regulating valve to actuator air inlet.  
Note DVC connecting port to be plugged.
- 6) Place keeper plate over square shaft protruding from S/R unit.
- 7) Increase air pressure slowly until actuator vane turns to mid-travel position.  
(See Figure 1 of actuator section.)
- 8) Keeper plate holes will then line up with threaded holes in spring housing.
- 9) Insert all screws through keeper plate holes and tighten to lock keeper plate in position. Disconnect air supply.
- 10) Separate spring housing from base plate by removing holding screws. Then remove spring housing.
- 11) If necessary to gain access to actuator case fixing screws also remove base plate by removing base plate screws. Take care with gasket / O-ring between base plate and actuator. (Service actuator as required per Seal Replacement Instructions section 1.2).

**Figure 5. Spring return unit section view**

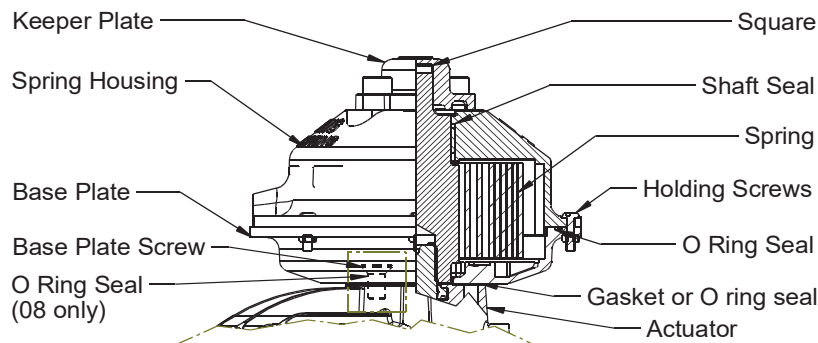

**1.3.2 Re-fitting of Spring unit**

- 1) If necessary replace base plate after replacing gasket or O-ring as appropriate.  
Refer to table 4 for spare part order numbers. Ensure the 4 countersunk base plate fixing screws are all fitted with O-rings (8i models only).
- 2) Ensure actuator vane is in mid-travel position.
- 3) Locate spring housing on drive shaft, rotate it to line up holding screw holes with base plate and replace holding screws.
- 4) Connect air line via pressure regulating valve to actuator air inlet.
- 5) Adjust air pressure until it balances the spring tension.
- 6) Loosen keeper plate screws. If air pressure is correct balancing spring tension will not bind. If binding, adjust air pressure until balanced.
- 7) Remove keeper plate completely.
- 8) Disconnect air supply.

**Installation, Operation & Maintenance Instructions Fisher 1068 series (Models 5i-15i)  
 ROTARY 1/4 TURN PNEUMATIC ACTUATORS  
 Suitable for use in safe area and hazardous gas/dust atmospheres (ATEX)**

**Section 2: Accessory mount for Fisher DVC2000 & DVC6200 Positioners**

**2.1.1 Mount kit for Fisher DVC Positioners**

- a) The Fisher DVC2000 & DVC6200 positioners can be direct mounted to actuator models 5i to 15i via a DVC mount kit.
- b) Two variants of the DVC mount kit are available one which fits to the model 05i actuator and another which fits to the 7i to 15i size actuators.
- c) Note, models 12i, 14i and 15i require an additional accessory mount plate (supplied with actuator as standard).

**Figure 6. General arrangement of the DVC mount kit.**

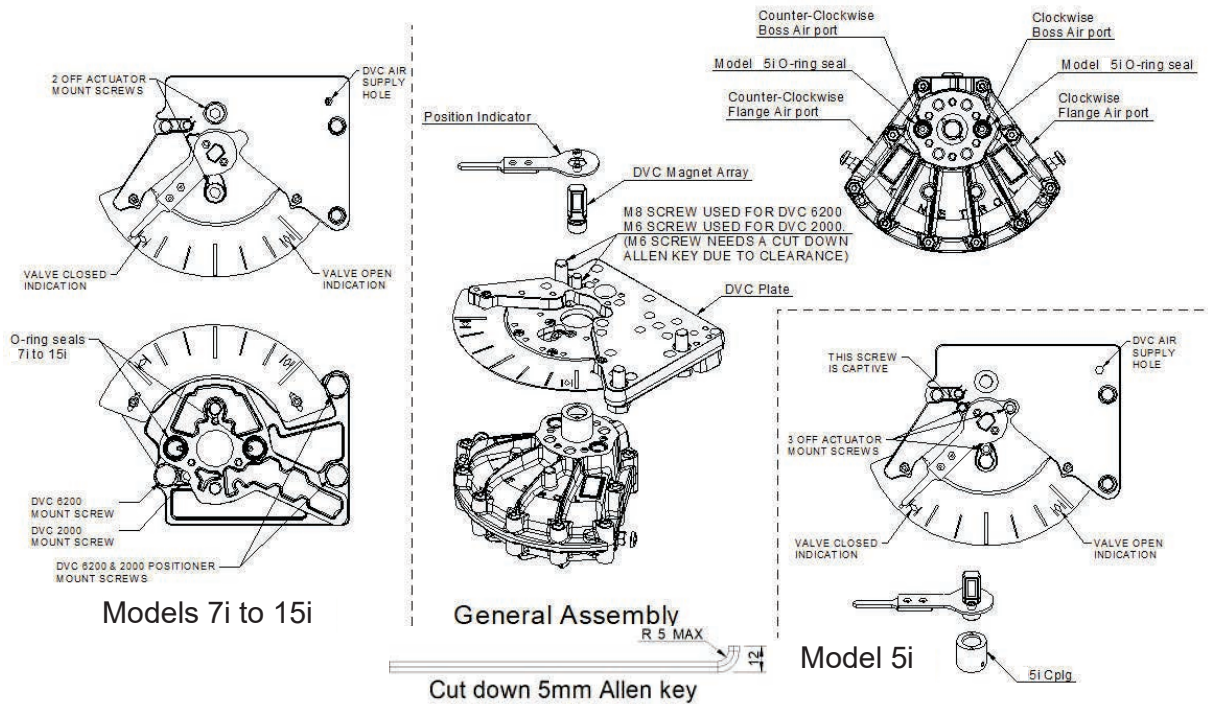

- d) Fitting DVC mount kit to Spring return actuator:  
 Note: model 5i (only) has a separate coupling fastened to the shorter output square (supplied with actuator as standard) for the DVC array to fit into.
  - First remove one of the boss air port screws (according to the desired direction of travel).
  - Fit O-ring seals as shown in figure 6, apply a small amount of grease to seals to hold in place while fitting DVC plate to actuator.
  - Fit DVC magnet array into actuator round shaft.
  - Fit position indicator over magnet array and secure onto actuator shaft using screws provided.
  - Valve open/closed indication plate can be reversed.
- e) If fitting to a Double acting actuator first follow section 2.1.1d then remove the opposing flange air port blanking plug, this will need to be externally piped to the DVC positioner.
- f) Note all fasteners are to be chemically locked using Loctite 222 or equivalent.

**Installation, Operation & Maintenance Instructions Fisher 1068 series (Models 5i-15i)  
 ROTARY 1/4 TURN PNEUMATIC ACTUATORS  
 Suitable for use in safe area and hazardous gas/dust atmospheres (ATEX)**

**2.1.2 Accessory mount for size 12i, 14i & 15i actuators**

a) To mount the DVC mount kit to actuator models 12i to 15i an accessory plate first needs to be fitted to the actuator (supplied pre-fitted to spring return actuators and loose within coupling kit for double acting actuators).

**Figure 7. Accessory plate for actuator models 12i to 15i**

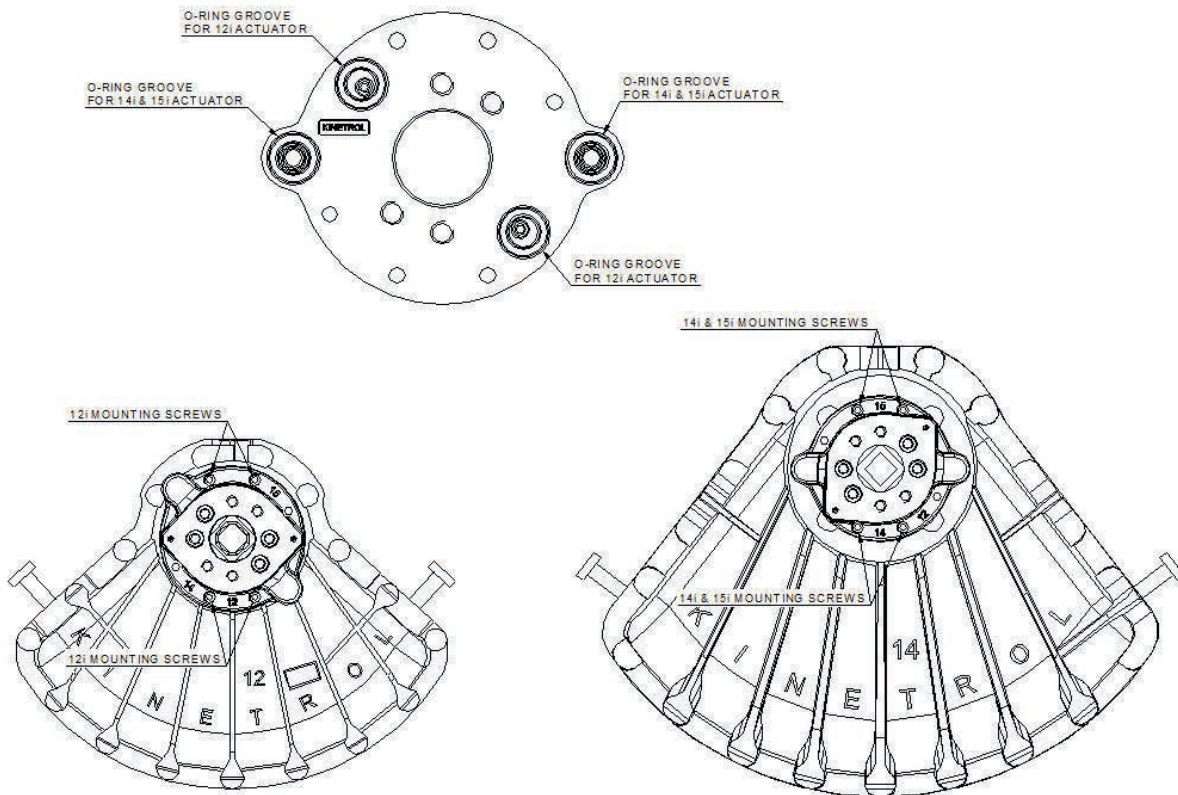

- b) O-rings seals are fitted in grooves as shown in figure 7.
- c) Plate fits to actuators in different orientations as shown in figure 7.
- d) DVC mount kit direct mounts to the accessory plate as per figure 6.

**Section 3: Installation of Valve Yokes and anti-backlash couplings**

**3.1.1 Fitting anti-backlash couplings to Spring Return actuators**

A range of anti-backlash couplings are available to direct couple to Fisher valves. A complete list of available options can be seen in table 11.

Note: Double acting actuators are fitted with solid couplings a complete list of available options can be seen in table 12.

**Figure 8. Anti-backlash coupling fitted to Spring return actuator**

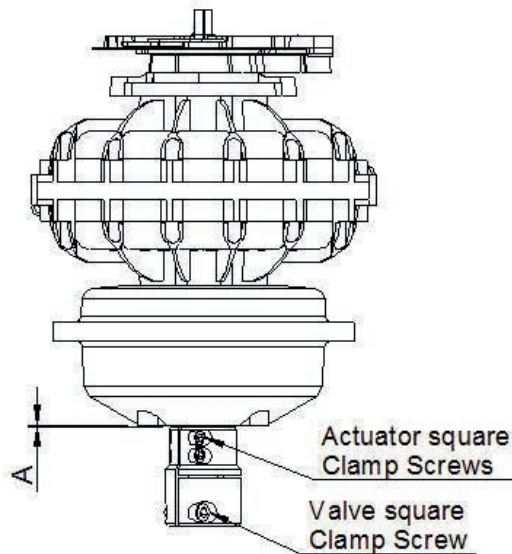

- a) Fit coupling to spring return actuator leaving approx 0.5mm (0.02”) gap between coupling face and spring mount face as shown on figure 8 dimension “A”.
- b) Apply a low strength anaerobic adhesive to actuator square clamp screw threads such as Loctite 222 and torque up screw / screws to value given in table 9.
- c) Double acting actuators do not use anti-backlash couplings due to clearance constraints a range of standard through square couplings are available.

**Table 9. Anti-backlash coupling clamp screw tightening torques**

Screw size	Tightening Torque	
M6	156 lbf.ins	17.6 Nm
M8	372 lbf.ins	42 Nm
M10	797 lbf.ins	90 Nm
M12	1416 lbf.ins	160 Nm



### 3.1.2 Mounting Yokes to Actuators & Spring Returns

Figure 9. Yoke fitted to Spring return actuator

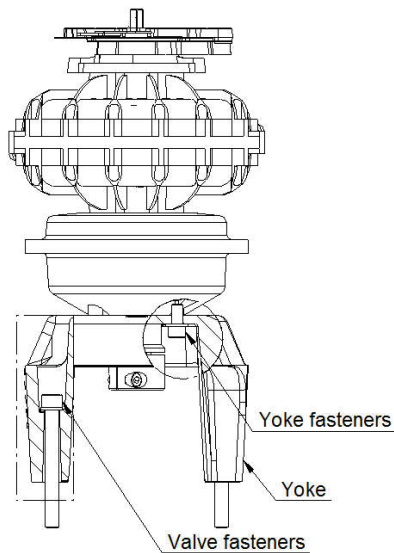

- First fit valve fasteners into yoke before fitting yoke to double acting / spring return actuator (some sizes lack the clearance to fit after).
- Apply a low strength anaerobic adhesive to yoke fastener screw threads such as Loctite 222 and torque up screws, consult TD111 for tightening torques.
- Note washers may not be supplied for some yoke and valve fasteners due to space constraints.

### 3.1.3 Mounting yokes to valves

Figure 10. Valve fitted to Spring return actuator

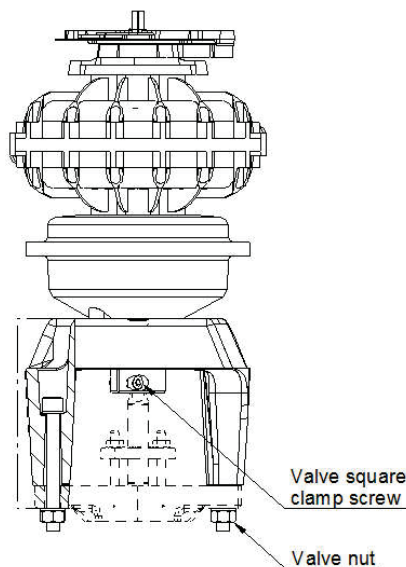

**Installation, Operation & Maintenance Instructions Fisher 1068 series (Models 5i-15i)  
 ROTARY 1/4 TURN PNEUMATIC ACTUATORS  
 Suitable for use in safe area and hazardous gas/dust atmospheres (ATEX)**

- a) Ensure valve opening and closing direction matches the opening and closing direction of the double acting / spring return actuator.
- b) Do not apply any end loading to actuator output drive, and ensure the actuator output drive and valve square are concentric to each other.
- c) If possible for optimal setting and to reduce any misalignment between actuator drive and valve square, the unit should be assembled in mid position.
- d) The unit should be assembled in the vertical position as shown in figure 9 with the valve securely held in place.
- e) Apply a low strength anaerobic adhesive to valve fastener screw threads.
- f) Fit actuator assembly as shown in figure 10 to valve taking care to centrally locate anti-backlash coupling onto valve square and loosely tighten valve fasteners.
- g) Apply a low strength anaerobic adhesive to valve square clamp screw threads and torque up screw / screws to value given in table 9.
- h) Now torque up valves fasteners, see table 10 for tightening torques.

**Table 10. Valve Fastener tightening torques**

Yoke Size	Tightening Torque	
Yoke 1	920 lbf.ins	104 Nm
Yoke 2	920 lbf.ins	104Nm
Yoke 3	1770 lbf.ins	200 Nm

- i) Now operate assembly open and closed a few times to check correct function and look for any alignment issues.

**3.1.4 Disassembly of Valve Yokes and anti-backlash couplings.**

Follow stages 3.1.1 to 3.1.3 but in reverse order.

Warning – Any fasteners including anti-backlash coupling clamp screws, removed or loosened during disassembly, must be replaced with new ones of the same grade, original fasteners must NOT be re-used.

**Installation, Operation & Maintenance Instructions Fisher 1068 series (Models 5i-15i)  
 ROTARY 1/4 TURN PNEUMATIC ACTUATORS  
 Suitable for use in safe area and hazardous gas/dust atmospheres (ATEX)**

**Table 11. Spring return actuator anti-backlash couplings**

Actuator Size	Part description	Shaft Diameter	Part Number
<b>5i</b>	Anti-Backlash Coupling (9mm)	1/2"	GE97906X012
	Anti-Backlash Coupling (11mm)	5/8"	GE97906X022
<b>7i</b>	Anti-Backlash Coupling (9mm)	1/2"	GE97906X032
	Anti-Backlash Coupling (11mm)	5/8"	GE97906X042
	Anti-Backlash Coupling (14mm)	3/4"	GE97906X052
	Anti-Backlash Coupling (19mm)	1"	GE97906X062
<b>8i</b>	Anti-Backlash Coupling (9mm)	1/2"	GE97906X072
	Anti-Backlash Coupling (11mm)	5/8"	GE97906X082
	Anti-Backlash Coupling (14mm)	3/4"	GE97906X092
	Anti-Backlash Coupling (19mm)	1"	GE97906X102
	Anti-Backlash Coupling (22mm)	1-1/4"	GE97906X112
	Anti-Backlash Coupling (27mm)	1-1/2"	GE97906X122
<b>9i</b>	Anti-Backlash Coupling (9mm)	1/2"	GE97906X132
	Anti-Backlash Coupling (11mm)	5/8"	GE97906X142
	Anti-Backlash Coupling (14mm)	3/4"	GE97906X152
	Anti-Backlash Coupling (19mm)	1"	GE97906X162
	Anti-Backlash Coupling (22mm)	1-1/4"	GE97906X172
	Anti-Backlash Coupling (27mm)	1-1/2"	GE97906X182
<b>10i</b>	Anti-Backlash Coupling (9mm)	1/2"	GE97906X192
	Anti-Backlash Coupling (11mm)	5/8"	GE97906X202
	Anti-Backlash Coupling (14mm)	3/4"	GE97906X212
	Anti-Backlash Coupling (19mm)	1"	GE97906X222
	Anti-Backlash Coupling (22mm)	1-1/4"	GE97906X232
	Anti-Backlash Coupling (27mm)	1-1/2"	GE97906X242
<b>12i</b>	Anti-Backlash Coupling (14mm)	3/4"	GE97906X252
	Anti-Backlash Coupling (19mm)	1"	GE97906X262
	Anti-Backlash Coupling (22mm)	1-1/4"	GE97906X272
	Anti-Backlash Coupling (27mm)	1-1/2"	GE97906X282
<b>14i</b>	Anti-Backlash Coupling (14mm)	3/4"	GE97906X292
	Anti-Backlash Coupling (19mm)	1"	GE97906X302
	Anti-Backlash Coupling (22mm)	1-1/4"	GE97906X312
	Anti-Backlash Coupling (27mm)	1-1/2"	GE97906X322
<b>15i</b>	Anti-Backlash Coupling (22mm)	1-1/4"	GE97906X332
	Anti-Backlash Coupling (27mm)	1-1/2"	GE97906X342

- a) Couplings designed to suit Fisher 8580, 8590, V150, V200, V300, V500 and CV500 valves.  
 b) Value in parentheses is the valve square size.

**Installation, Operation & Maintenance Instructions Fisher 1068 series (Models 5i-15i)  
 ROTARY 1/4 TURN PNEUMATIC ACTUATORS  
 Suitable for use in safe area and hazardous gas/dust atmospheres (ATEX)**

**Table 12. Double acting actuator solid couplings**

Actuator Size	Part description	Shaft Diameter	Part Number
7i	Solid Coupling (9mm)	1/2"	GE97906X352
	Solid Coupling (11mm)	5/8"	GE97906X362
8i	Solid Coupling (9mm)	1/2"	GE97906X372
	Solid Coupling (11mm)	5/8"	GE97906X382
	Solid Coupling (14mm)	3/4"	GE97906X392
	Solid Coupling (19mm)	1"	GE97906X402
	Solid Coupling (22mm)	1-1/4"	GE97906X412
9i	Solid Coupling (14mm)	3/4"	GE97906X422
	Solid Coupling (19mm)	1"	GE97906X432
	Solid Coupling (22mm)	1-1/4"	GE97906X442
10i	Solid Coupling (14mm)	3/4"	GE97906X452
	Solid Coupling (19mm)	1"	GE97906X462
	Solid Coupling (22mm)	1-1/4"	GE97906X472
	Solid Coupling (27mm)	1-1/2"	GE97906X482
12i	Solid Coupling (19mm)	1"	GE97906X492
	Solid Coupling (22mm)	1-1/4"	GE97906X502
	Solid Coupling (27mm)	1-1/2"	GE97906X512
14i	Solid Coupling (19mm)	1"	GE97906X522
	Solid Coupling (22mm)	1-1/4"	GE97906X532
	Solid Coupling (27mm)	1-1/2"	GE97906X542
15i	Solid Coupling (22mm)	1-1/4"	GE97906X552
	Solid Coupling (27mm)	1-1/2"	GE97906X562

- a) Couplings designed to suit Fisher 8580, 8590, V150, V200, V300, V500 and CV500 valves.  
 b) Value in parentheses is the valve square size.