

# Service Instructions for Yarway™ AT-37/47 Cryogenic Injector

This instruction manual was prepared by Emerson.

Do not install, operate or maintain this product without being fully trained and qualified in valve, actuator and accessory installation, operation and maintenance.

To avoid personal injury or property damage it is important to carefully read, understand, and follow all of the contents of this manual, including all safety cautions and warnings.

If you have any questions about these instructions, contact your [Emerson sales office](#) before proceeding.

## Installation

### **⚠ WARNING**

Always wear protective gloves, clothing, and eyewear when performing any installation operations. Check with your process or safety engineer for any other hazards that may be present from exposure to process media.

Personal injury or equipment damage caused by sudden release of pressure may result if the desuperheater is installed where service conditions could exceed the limits given on the product nameplate. To avoid such injury or damage, provide a relief valve for over-pressure protection as required by government or accepted industry codes and good engineering practices.

### **CAUTION**

When ordered, the desuperheater configuration and construction materials were specified to meet particular pressure, temperature, pressure drop, and fluid conditions. Do not apply any other conditions to the desuperheater without first contacting your local Emerson sales office .

## Maintenance

### **⚠ WARNING**

Avoid personal injury or property damage from sudden release of process pressure or bursting of parts. Before performing any maintenance operations:

- Do not remove the actuator from the valve while the valve is still pressurized.
- Always wear protective gloves, clothing, and eyewear when performing any maintenance operations.
- Disconnect any operating lines providing air pressure, electric power, or a control signal to the actuator. Be sure the actuator cannot suddenly open or close the valve.
- Use bypass valves or completely shut off the process to isolate the valve from process pressure. Relieve process pressure from both sides of the valve. Drain the process media from both sides of the valve.
- Safely vent the power actuator loading pressure.
- Use lock-out procedures to be sure the above measures stay in effect with you work on the equipment.
- The valve packing box may contain process fluids that are pressurized, even with the valve has been removed from the pipeline. Process fluids may spray out under pressure when removing the packing hardware or packing rings.
- Check with your process or safety engineer for any other hazards that may be present from exposure to process media.

### **CAUTION**

When adjusting the travel stop for the closed position of the valve ball or disk, refer to the appropriate valve instruction manual for detailed procedures. Undertravel or overtravel at the closed position may result in poor valve performance and/or damage to the equipment .

Neither Emerson, Emerson Automation Solutions, nor any of their affiliated entities assumes responsibility for the selection, use or maintenance of any product. Responsibility for proper selection, use, and maintenance of any product remains solely with the purchaser and end user.

Yarway is a mark owned by one of the companies in the Emerson Automation Solutions business unit of Emerson Electric Co. Emerson Automation Solutions, Emerson, and the Emerson logo are trademarks and service marks of Emerson Electric Co. All other marks are the property of their respective owners.

The contents of this publication are presented for informational purposes only, and while every effort has been made to ensure their accuracy, they are not to be construed as warranties or guarantees, express or implied, regarding the products or services described herein or their use or applicability. All sales are governed by our terms and conditions, which are available upon request. We reserve the right to modify or improve the designs or specifications of such products at any time without notice.

Emerson Automation Solutions  
Marshalltown, Iowa 50158 USA  
Sorocaba, 18087 Brazil  
Cernay, 68700 France  
Dubai, United Arab Emirates  
Singapore 128461 Singapore

[www.Fisher.com](http://www.Fisher.com)



## YARWAY A.T.-TEMP CRYOGENIC DESUPERHEATER INSTALLATION AND MAINTENANCE INSTRUCTIONS

Before installation these instructions must be fully read and understood



### UNPACKING

The A.T.-Temp Cryogenic desuperheater is packed with the greatest of care in wooden boxes or cartons for protection during handling and transit to site. After hydrostatic testing, the unit is flushed through with a high grade of preservative to protect machined and internal surfaces from corrosion. If it is found, however, that damage has occurred during shipment, then this should be reported immediately to your forwarder or Yarway representative.

Particular care should be taken when removing the A.T.-Temp Cryogenic desuperheater from its packing and your special attention is required to check carefully that no damage has occurred to flange faces, threading, actuators, connecting pipes, etc. (see figure 1). Hoist the unit with straps around the body as depicted, do not lift the unit by the hoisting lug on the actuator.

### INSTALLATION OF THE A.T.-TEMP CRYOGENIC DESUPERHEATER

Before installation, check the A.T.-Temp Cryogenic desuperheater, actuator and accessories for any visible damage. Check that the information on the documentation, identification plate and tag number complies with the order specification. Remove the A.T.-Temp Cryogenic desuperheater carefully from its packaging, lifting by means of straps around the body, or use the hoisting lug if provided. Do not use the water inlet connection, yoke, actuator or any of its accessories for lifting. Leave the flange covers in place during transportation, until ready to install in the pipework. When installing the A.T.-Temp Cryogenic desuperheater use gaskets and bolting material in accordance with the relevant piping code, for example ASME/ANSI B31.3 or EN. Place the gasket onto the mounting flange and carefully insert the nozzle into the branch pipe. Ensure that the spray cylinder is pointed in the direction of the gas flow before tightening the mounting bolts (see figure 2).

**Note:** the A.T.-Temp Cryogenic desuperheaters should be installed free of 'forces, moments and torques'.

# YARWAY A.T.-TEMP CRYOGENIC DESUPERHEATER

## INSTALLATION AND MAINTENANCE INSTRUCTIONS

The A.T.-Temp Cryogenic desuperheater is provided with a lower body length, as specified in the contract drawing and the mounting branch for the process pipework must be manufactured to suit.

The length of this branch should be such, that the centerline of the spray cylinder is located on the centerline of the process line ( $\pm 5$  mm). The mounting branch nominal bore and pipe schedule (check the applicable process piping code), should be verified and in line with the dimensions mentioned on the certified drawing.

The minimum pipe run, required downstream of the A.T.-Temp Cryogenic desuperheater, varies with each individual application and would be specified by Yarway at the enquiry stage. This straight run is needed to prevent erosion due to impingement of droplets against pipewalls, valves and fittings and is normally in the order of 2 to 3 meters for hydrocarbons, as a minimum (no upstream straight length is normally required).

The distance from the A.T.-Temp Cryogenic desuperheater to the temperature sensor is nominally 6 to 7 meters, although the distance specific to the application would be advised by Yarway at the enquiry stage. Longer distances will ensure that full evaporation will take place at lower velocities.

The temperature sensor should be located in the upper half of the pipe, avoid branching of the process pipework between the A.T.-Temp Cryogenic desuperheater and the sensor (see figure 4).

FIGURE 1

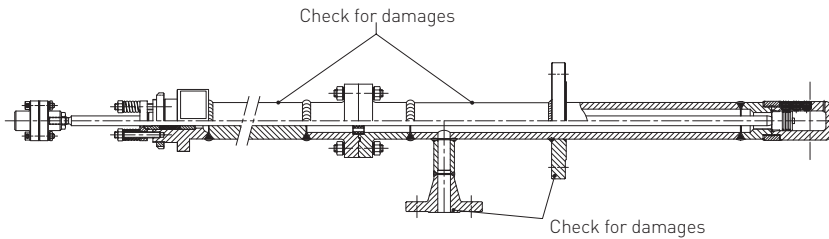

FIGURE 2

LIQUID FLANGE POSITIONS

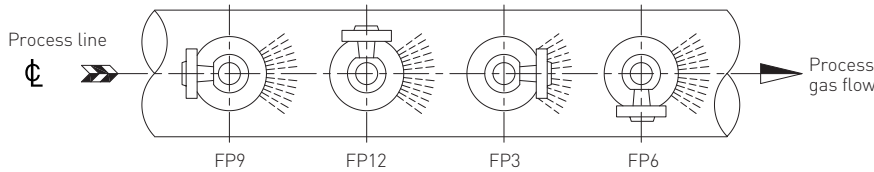

FIGURE 3

HANDWHEEL POSITIONS

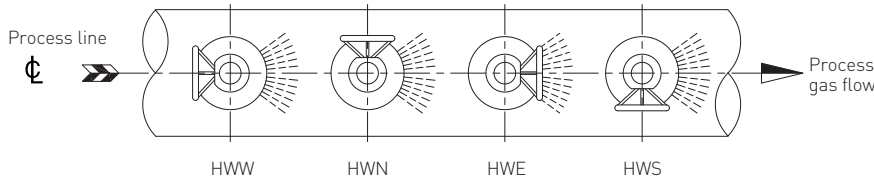
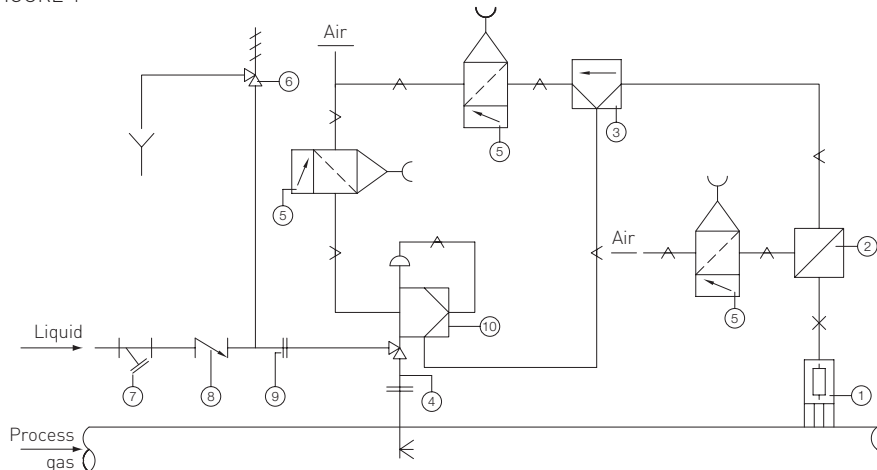

FIGURE 4



Item	Description
1	Temperature sensor
2	Temperature transmitter
3	Temperature controller
4	A.T.-Temp Cryogenic desuperheater
5	Air filter regulator
6	Safety relief valve
7	Strainer
8	Check valve
9	Flange
10	Pneumatic -or E/P- positioner

# YARWAY A.T.-TEMP CRYOGENIC DESUPERHEATER STANDARD DUTY

## INSTALLATION AND MAINTENANCE INSTRUCTIONS

Pipe bends should always be of the long radius type to assist in keeping the liquid droplets in suspension, until complete evaporation has taken place. Installation may be in vertical or horizontal piping, but the direction of liquid injection should always be with the process gas flow.

The A.T.-Temp Cryogenic Desuperheater may be mounted at 90° to the process pipe, for all flow orientations, but avoid installation in the vertically downwards position, wherever possible (see figure 5).

Yarway supplies the A.T.-Temp Cryogenic desuperheater as follows:

Identification number:

xx. 37. xxxxx - Fabricated type with non-balanced stem.

xx. 47. xxxxx - Fabricated type with semi-balanced stem and oversized trim all with the spray cylinder tack welded to the body extension pipe.

**Note:** horizontal orientated A.T.-Temp Cryogenic desuperheater has to be installed with a support for weight compensation.

The liquid supply should be of a good quality; clean and filtered, and should have a constant pressure as specified in the order documents. Each liquid supply line should be protected with its own individual strainer with a maximum element perforation size of 0.1 mm (0.4 mm acceptable for nozzles 'E' size and up). Where there are positive shut-off components in the liquid supply (including electric actuators) then a safety relief valve of an approved type should be fitted. As in the case of the process pipework, use gasketing and bolting in accordance with the relevant piping code. Flush out the liquid line before connecting to the A.T.-Temp Cryogenic desuperheater mounting flange (see figure 6).

FIGURE 5

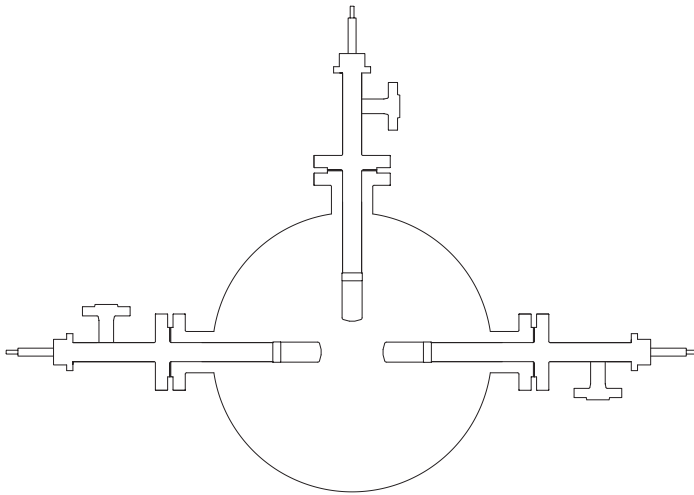
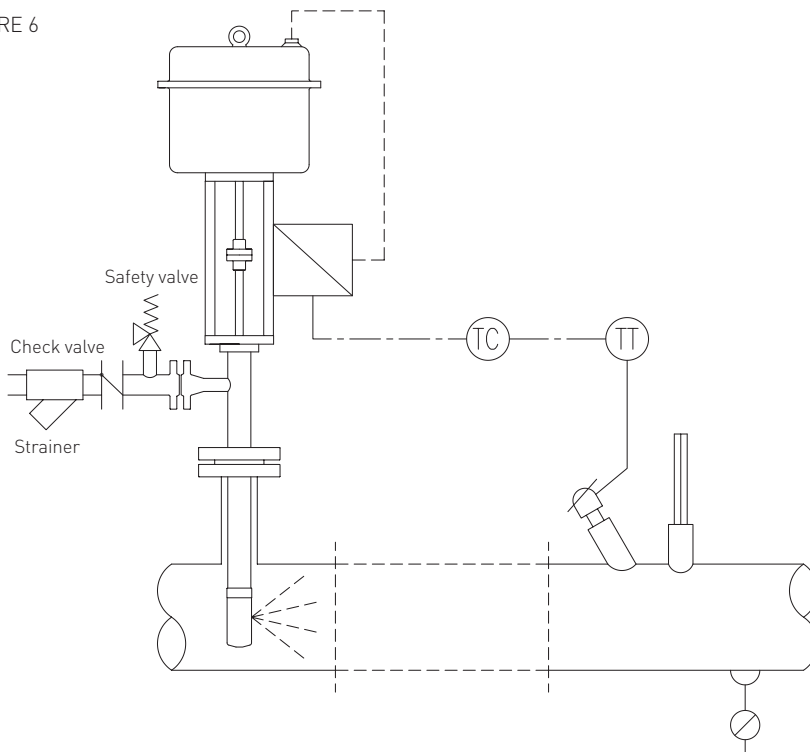

FIGURE 6



# YARWAY A.T.-TEMP CRYOGENIC DESUPERHEATER STANDARD DUTY

## INSTALLATION AND MAINTENANCE INSTRUCTIONS

### START-UP

Ensure that all components are installed correctly. Connection of electrical supplies and instrument air piping should be in accordance with the manufacturer's instruction manual. Verify and adjust, if necessary, set points for filter regulators and valve positioners, following the manufacturer's recommendations. Similarly, calibrate the temperature transmitter/controller, verifying automatic response to temperature changes. Check the liquid pressure at the A.T.-Temp Cryogenic desuperheater. Verify the operation of the temperature transmitter and controller by manually increasing and decreasing the output signal and observing indicated and recorded temperatures. When satisfactory coordination between instrument signals and temperature are attained, adjustment of the set point can be made and the system transferred to automatic operation. It is recommended to record the various process coordinates, over a sustained period, to verify operation, adjusting where necessary.

### MAINTENANCE

**Note:** maintenance of the A.T.-Temp Cryogenic desuperheater is straight forward and does not require any special tools or training. Care should be taken during any maintenance operation, particularly when working with grinders, compressed air and rotating machinery. It is imperative that safety glasses and protective workwear are used in accordance with Standard Safety Procedures. In case of doubt, consult your Supervisor or Safety Officer before commencing any work on the equipment.

#### Removal

Before removing the A.T.-Temp Cryogenic desuperheater from the system, ensure that both the process -and injection liquid pipework are pressureless and vented. Isolate any electrical supplies to the actuator and/or ancillaries, prior to disconnection. Vent and remove instrument air supply piping. Loosen process flange and liquid flange bolting, but vent connections before complete removal.

The A.T.-Temp Cryogenic desuperheater may now be removed from the system. It is recommended that the A.T.-Temp Cryogenic desuperheater is transported to a convenient workshop which has a workbench and vice. Lift the unit by means of straps around the body. Do not attempt to lift the A.T.-Temp Cryogenic desuperheater by the yoke, actuator or any of its accessories. Depending upon the type of actuator fitted, various stem couplings are used. Measure accurately, and record the dimensions A and B (see figure 7) for reassembly purposes. Also record positions of any levers or specials fixings, sketching if necessary, prior to removal. If any work is required on the actuator, then please refer to the actuator manufacturer's manual.

FIGURE 7

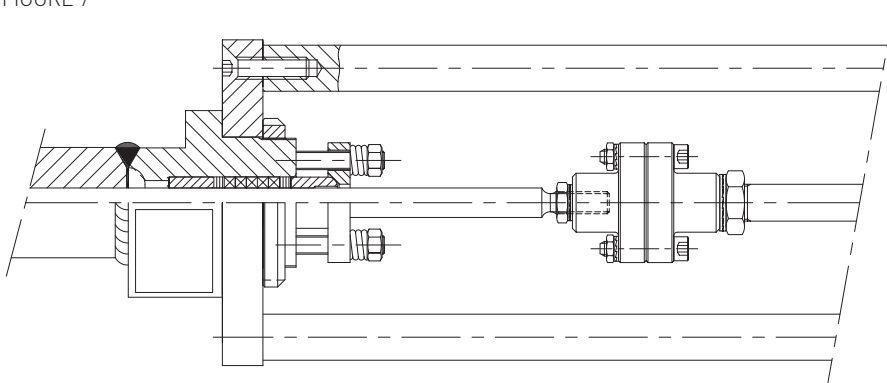
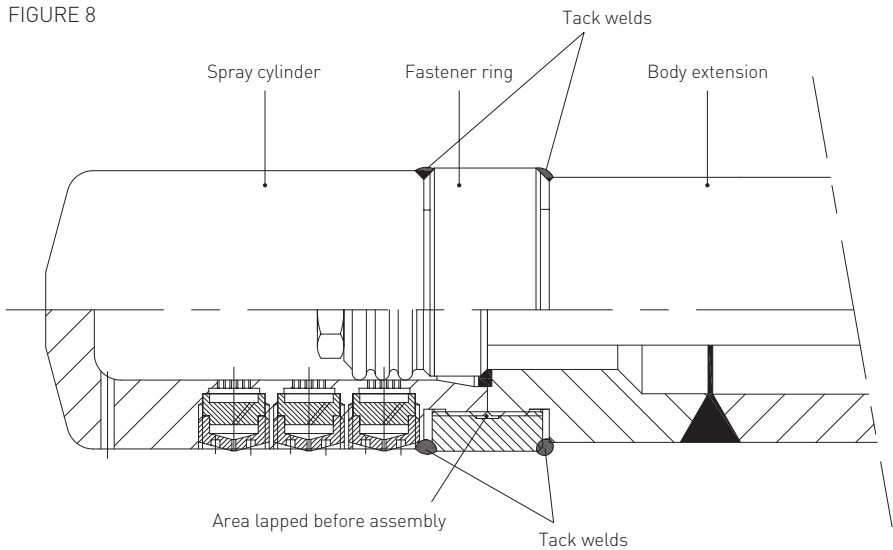

FIGURE 8



# YARWAY A.T.-TEMP CRYOGENIC DESUPERHEATER

## INSTALLATION AND MAINTENANCE INSTRUCTIONS

### Disassembly (see figure 8)

The A.T.-Temp Cryogenic desuperheater can be disassembled, most easily when in the horizontal position with the body extension section clamped firmly in the vice. Grind off the nozzle tack welds, using any standard type of angle grinder. Make sure that the weld is removed sufficiently to allow rotation of the fastener ring, without fouling.

Unscrew the fastener ring by rotating anticlockwise. Note that the threading on the body extension is right handed. Tapping the fastener ring with a hammer may facilitate removal. Note that the threading on the spray cylinder is left handed. If difficulties are encountered with the removal of the fastener ring, then this item may be removed by grinding through at two diametrically opposite points. Please be careful not to damage the body and spray cylinder threading.

### Spray cylinder

Once removed, inspect the condition of the cylinder internally, using a flashlight. Scratches and blemishes may be removed by either polishing or honing.

The cylinder bore should not exceed 32 mm (model 37) with a maximum eccentricity of 0.25 mm. Debris can be removed from the nozzles by blowing through with compressed air.

Inspect the nozzle atomizer outlet holes. These should not show any undue elliptical wear, roughness or damage or this will have a detrimental effect on the A.T.-Temp Cryogenic desuperheater performance. Carefully clean the cylinder threading, dressing where necessary, with a small file.

### Body extension

Examine the threading on the body extension, dressing where necessary, with a small file. If care is exercised, during routine maintenance, the valve body extension should never require any repair work. If this threading does become accidentally damaged, however, then weld repair may be possible. It should be noted that this job is for a specialist welder and filler materials must be compatible with both the base material and the service conditions. In the event that such work is necessary, please consult Yarway or Emerson for further advice.

### Stem assembly

Withdraw the stem with piston. The piston and stem are always supplied as a complete assembly.

In case desuperheater is designed with piston rings, replace as a matter of course, any time that the unit is disassembled. Take care not to overstress the piston rings when fitting. The rings are marked 'top' and should always point in the direction of the stuffing box, for proper functioning.

If the piston (PTFE version) shows no signs of wear and tear, then it may be re-used. Examine the condition of the stem, where it runs in the stuffing box, remove any packing material with a fine grade emery cloth, polishing in the longitudinal direction.

### Stuffing box

Remove all rings, springs and packing material from the valve body. Clean the stuffing box carefully, using a rotating wire brush and/or honing device. Cleanless of the packing area is vital for proper valve sealing. Do not use grease or lubricants in combination with PTFE Chevron type packing! The actual packing design is mentioned on the project related valve drawing.

Only ever use genuine Yarway components, as they are supplied as matched sets (see figure 9).

FIGURE 9

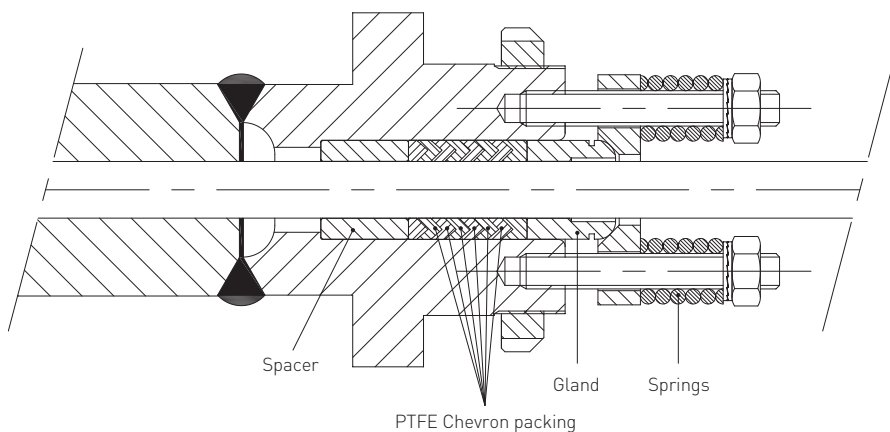

# YARWAY A.T.-TEMP CRYOGENIC DESUPERHEATER STANDARD DUTY

## INSTALLATION AND MAINTENANCE INSTRUCTIONS

### Reassembly

Before reassembling the valve, lubricate all threads with a suitable anti-seize compound such as Nickel based compounds. Do not use grease or other oil based lubricants as these may lead to dismantling problems later. Reassemble the spray cylinder onto the body extension. Use a fine grade polishing paste to lap the seating area of cylinder and body extension. The seal is metal to metal so a concentric seat area is vital. Always use a new fastener ring. Set the spray cylinder into the correct orientation (the liquid spray should always be in the same direction as the gas flow) and tighten the fastener ring.

### Tack welding

After reassembly, the spray cylinder should be tack welded for security. It is essential that this welding is carried out by a competent welder. A Welding Procedure Specification is available from Yarway, upon request. Both TIG and ARC welding methods are acceptable and the recommended electrode material is ER NiCrMo3. A minimum of 4 (Model 37) or 8 (Model 47) 8 mm long tacks are required, diametrically opposite, with one weld securing the fastener ring to the body extension, the other securing the spray cylinder to the fastener ring. After welding, use a suitable dye penetrant method to check the weld. No cracks are permitted. If necessary, grind-off, re-check until a satisfactory weld is obtained (see figure 10).

### Re-installation

Refit the actuator onto the A.T.-Temp Cryogenic desuperheater, referring to the notes taken during disassembly, for re-setting the stem position.

Before re-installing the A.T.-Temp Cryogenic desuperheater, make sure that the connecting flange faces are cleaned thoroughly and any gasket material removed. Insert the A.T.-Temp Cryogenic desuperheater into the pipework and check that the nozzle is orientated correctly with the spray with the direction of the gas flow. Apply a suitable lubricating compound to the bolts and nuts and tighten evenly, in accordance with the manufacturer's recommendations. Before connecting the liquid line, flush through and check for any contamination or restriction in the supply. Follow the procedure for 'start-up', as detailed earlier in the installation instructions. Check the flange and stuffing box tightness. Do not overtighten the stuffing box packing gland as this may prevent proper A.T.-Temp Cryogenic desuperheater operation. In the event of persistent leakage through the stem packing, the unit should be removed to the workshop, for further examination. Experience shows that providing the stuffing box, packing and stem are clean and score, leak-free tightness can be achieved. Tighten stuffing box by evenly turning the nuts compressing the springs.

### SPARE PARTS

Make sure that the identification number (indicated on the nameplate) is verified and specified when ordering spare parts. For cross-sectional drawings and part lists, see the next page.

FIGURE 10 - DETAILS

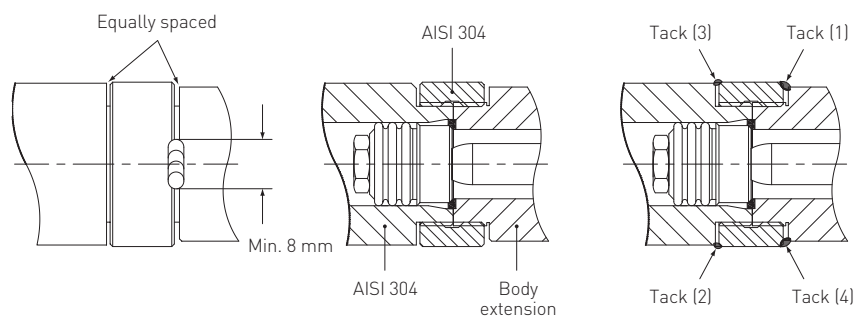



# YARWAY A.T.-TEMP CRYOGENIC DESUPERHEATER

## INSTALLATION AND MAINTENANCE INSTRUCTIONS

FIGURE 11

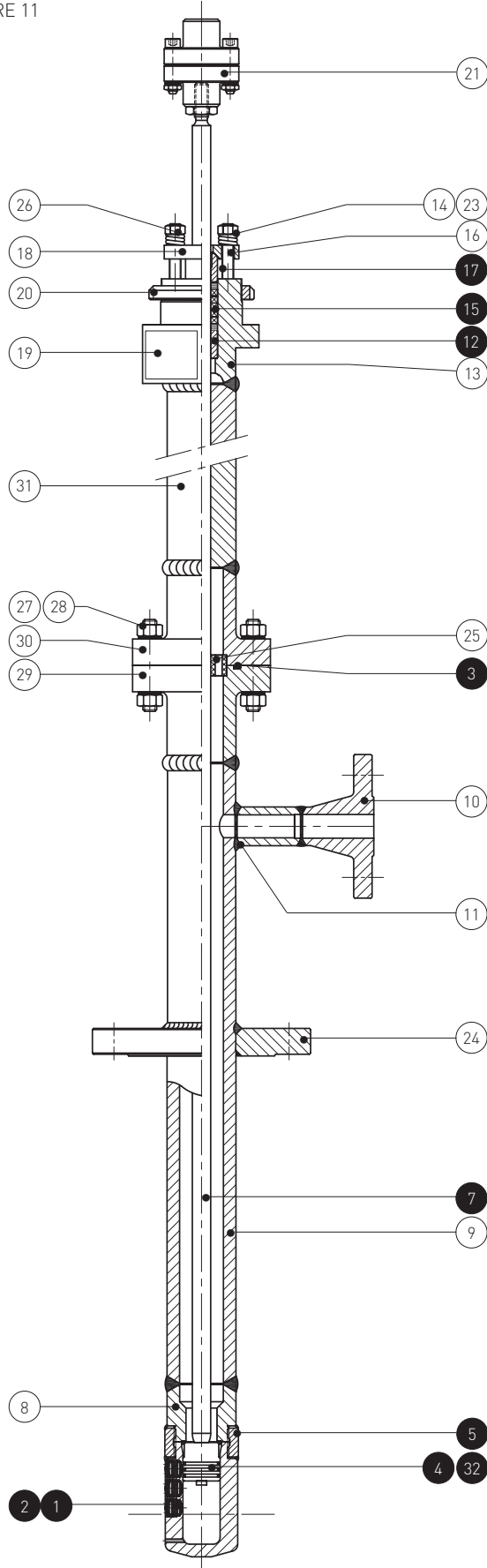

TABLE 1 - STANDARD MATERIALS

Item	Name	Material
1•	Spray cylinder	SA 182 F304L
2•	Nozzle assy	SA 182 F304L
3•	Spiral wound packing	PTFE/316L
4•	Piston	PTFE 25% reinforced/aluminium bronze*
5•	Fastener ring	SA 182 F304L
7•	Stem	SA 182 F316L
8	Seat housing	SA 182 F304L
9	Body	SA 312 TP304L
10	Liquid flange	SA 182 F304/F304L dual certified
11	Adaptor	SA 182 F304L
12•	Stem bushing lower	Aluminium bronze
13	Packing box	SA 182 F304L
14	Nut	SA 194 8MA
15•	Packing set	PTFE V-rings
16	Stud	SA 320 B8 CL.2
17•	Stem bushing upper	Aluminium bronze
18	Gland plate	SA 182 F304L
19	Name plate	AISI 316
20	Lock nut	Stainless steel
21	Coupling	SA 182 F304L
23	Securing washer	Stainless steel
24	Vapor flange	SA 182 F304/F304L dual certified
25	Guiding	PTFE
26	Spring	AISI 631 17-7 PH
27	Shoulder bolt	SA 320 B8 CL.2
28	Securing washer	Stainless steel
29	Flange female	SA 182 F304L
30	Flange male	SA 182 F304L
31	Extension pipe	SA 312 TP304L
32•	Piston rings	Aluminium bronze*

### NOTES

\* For valve design class 600/900

• Recommended spares

Other materials are available upon request

### Certification

The cryogenic A.T.-Temp complies with the rules of ASME B16.34.

EN standard flanges are available as an option. If applied within the E.C., a certificate of conformity to PED will be issued. The nameplate will bear the CE-marking as applicable for the product.

Materials and data of units supplied, may deviate from this brochure.

Please consult order documents in case of doubt.

# YARWAY A.T.-TEMP CRYOGENIC DESUPERHEATER

## INSTALLATION AND MAINTENANCE INSTRUCTIONS

---

### INSPECTION PROCEDURE

---

Spray nozzle assemblies (1) and (2), fastener rings (5), piston (4), piston rings (32) shall be considered wear parts. The materials selected are such that they do cope with the conditions as found on applications in liquid/gas environments of cryogenic conditions. Thermal cycling does occur and users should realize that the temperature differentials at Cryogenic desuperheaters can be significant.

It is recommended to check the spray nozzle assembly, with the integrally vacuum brazed injection nozzles, fastener ring and tack-welds after the first year of service.

At the inspection, by use of dye check or fluor penetrant investigation, these parts shall be checked for cracks. Parts with hair crack indications shall not be re-used. 'Defect free' heads in such installations shall be inspected once per 2 year of operation.

It is advised to replace the above mentioned components at least once per 5 years of service.

Taking these precautions has historically proven to give reliable service.

**Note:** spray nozzle assemblies may have been made specifically for the specification. Delivery time of such components will be 8 weeks.

### STORAGE PROCEDURE

---

Upon receipt, check both the A.T.-Temp Cryogenic desuperheater and the packing case for any transit damage. Any damage to the A.T.-Temp Cryogenic desuperheater should be reported immediately to Yarway or their local agent. Any damage to the packing container should be rectified to prevent the ingress of dust or water, prior to placing the equipment into storage.

Check the information contained on the identification plate-tag plate and documentation and return the unit to its packing with protective covers in place.

For short term storage, up to 6 months duration, no additional preservation measures are necessary. Retain the unit in its original packing in a clean, dry indoor location. If outdoor storage is unavoidable, then the packing case should be enclosed in a waterproof covering.

For long term storage use only a dry indoor location. Ensure that the A.T.-Temp Cryogenic desuperheater is dry and free from moisture. Retain A.T.-Temp Cryogenic desuperheater in its original packing and inspect at 3 monthly intervals to ensure that no deterioration has occurred.

Before placing the A.T.-Temp Cryogenic desuperheater into service, stroke valve spindle a few times and inspect other components, such as actuator, seals, etc., to ensure correct functioning.

Follow the procedure for installation as detailed in the operating and maintenance instruction manual.

**Note:** materials and data of units supplied may deviated from this Instruction Manual. Please consult order documents in case of doubt.

A.T.-Temp Cryogenic desuperheater is classified under European Directive 97/23/EC under category I or II with CE-marking.