

Type A11 High Performance Butterfly Valve

| | |
|---|----|
| Introduction | 1 |
| Scope of Manual | 1 |
| Description | 1 |
| Specifications | 3 |
| Installation | 3 |
| Adjusting the Travel Stops | 3 |
| Preparing for Installation | 4 |
| Valve Orientation | 4 |
| Installing the Valve | 6 |
| Thrust Washers | 7 |
| Packing Adjustment and Shaft Bonding | 7 |
| Maintenance | 8 |
| Removing the Valve | 9 |
| Packing Maintenance | 9 |
| Lantern Rings | 10 |
| Lubrication Fittings and Purge Connectors | 10 |
| Seal Maintenance | 10 |
| Soft Seal Installation | 11 |
| Metal and Phoenix III Seal Installation | 11 |
| Cryogenic Seal Installation | 13 |
| Valve Shaft/Disc Pin Unit Maintenance | 13 |
| Gasket Retainer | 15 |
| Bearing Maintenance | 15 |
| Parts Ordering | 16 |
| Parts List | 17 |

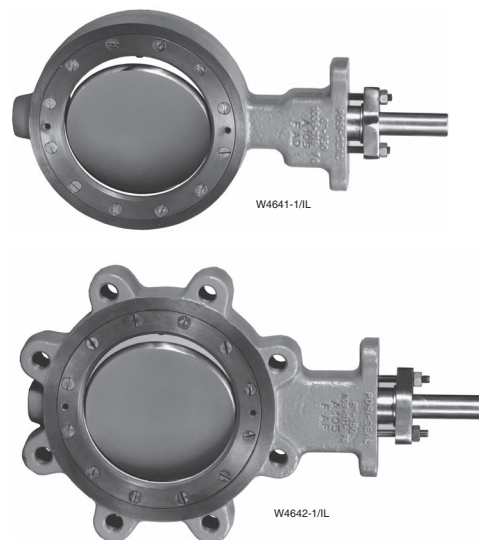

Figure 1. Type A11 Valve

and understanding the contents of this manual. If you have any questions about these instructions, contact your Emerson Process Management sales office before proceeding.

Note

Neither Emerson, Emerson Process Management, nor any of their affiliated entities assumes responsibility for the selection, use and maintenance of any product. Responsibility for the selection, use, and maintenance of any product remains with the purchaser and end-user.

Introduction

Scope of Manual

This instruction manual includes installation, maintenance, and parts information for Type A11 High Performance Butterfly Valves (figure 1) in Class 150, 300, and 600. For Class 900 and 1500 valves, contact your Emerson Process Management™ sales office.

For information about the actuator and accessories, please refer to the separate instruction manuals for these items.

Do not install, operate, or maintain a Type A11 valve without first • being fully trained and qualified in valve, actuator, and accessory installation, operation, and maintenance, and • carefully reading

Description

Type A11 High Performance Butterfly Valves are available in either a flangeless wafer or a single flange design, with a variety of seal, valve body, and internal components. These valves feature a dynamic sealing design that is used in a variety of demanding applications.



A11 Valve

Table 1. Specifications

| | |
|--|--|
| <p>Available Configurations</p> <p>Valve Sizes Class 150 and 300: Size ■ 30, ■ 36, ■ 42 and ■ 48-inch Class 600: Size ■ 3, ■ 4, ■ 6, ■ 8, ■ 10, ■ 12, ■ 14, ■ 16, ■ 18, ■ 20 and ■ 24-inch</p> <p>Valve Body: Wafer-style and single-flange style in Class ■ 150/150, ■ 150, ■ 300, ■ 600, ■ 900 and ■ 1500</p> <p>Maximum Inlet Pressure Consistent with applicable ASME class pressure/temperature ratings per ASME B16.34 unless such ratings are limited by material temperature capabilities.</p> <p>Construction Materials Refer to Bulletin 21.1:A11</p> <p>Disc Rotation Clockwise (CW) to close</p> <p>Valve Body Classification Face-to-face dimensions for Type A11 valve is in compliance with MSS SP-68 and API 609 standards. Valve bodies are designed for installation between standard pipe flanges: for 3 inch through 24-inch sizes (ASME B16.5); for sizes greater than 24-inch (MSS SP-44 or API 605) as specified on valve order</p> | <p>Seal Temperature Capabilities</p> <p>PTFE (Standard) Seal: For application ranges from -62 to 232°C (-80 to 450°F)</p> <p>Phoenix III Seal: For application ranges from -73 to 232°C (-100 to 450°F)</p> <p>High-Temperature Seals: <i>Standard:</i> Metal or NOVEX to 820°C (1500°F) <i>Optional:</i> 17-4PH H1150M to 454°C (850°F)</p> <p>Cryogenic Seals: <i>CTFE:</i> -254 to 149°C (-425 to 300°F) <i>NOVEX:</i> -254 to 260°C (-425 to 500°F)</p> <p>Approximate Weights See tables 2 and 3</p> <p>Actuator Types Available ■ Locking-lever manual actuators, ■ worm-gear manual actuators, ■ spring-return pneumatic actuators, ■ double-acting pneumatic actuators, and ■ electric actuators</p> <p>ENVIRO-SEAL® Packing This optional ■ PTFE or ■ graphite packing system provides improved sealing, guiding, and transmission of loading force to control liquid and gas emissions (see figure 7). See Bulletin 59.3:041 ENVIRO-SEAL Packing Systems for Rotary Valves for more information. Consult factory for larger sizes; they may require a special valve body.</p> |
|--|--|

Table 2. Approximate Weight for Size 30 through 72-Inch Valves

| VALVE SIZE, INCHES | CLASS 150 | | CLASS 150/150 | | CLASS 300 | |
|-----------------------|-----------|---------------|---------------|---------------|-----------|---------------|
| | Wafer | Single Flange | Wafer | Single Flange | Wafer | Single Flange |
| kg | | | | | | |
| 30 | 528 | 736 | 365 | 525 | 952 | 1406 |
| 36 | 806 | 1120 | 626 | 897 | 1315 | 1989 |
| 42 | 1302 | 1550 | 1100 | 1328 | 2263 | 2726 |
| 48 | 1904 | 2248 | 1604 | 1907 | 3056 | 4177 |
| 54 | 2197 | 2790 | 2150 | 2893 | --- | --- |
| 60 | (1) | (1) | 2417 | 3267 | --- | --- |
| 66 | (1) | (1) | 3903 | 5117 | --- | --- |
| 72 | (1) | (1) | (1) | (1) | --- | --- |
| lbs | | | | | | |
| 30 | 1164 | 1623 | 805 | 1157 | 2100 | 3100 |
| 36 | 1778 | 2470 | 1380 | 1978 | 2900 | 4385 |
| 42 | 2871 | 3418 | 2425 | 2928 | 4989 | 6009 |
| 48 | 4198 | 4955 | 3537 | 4204 | 6737 | 9209 |
| 54 | 4844 | 6151 | 4747 | 6379 | --- | --- |
| 60 | (1) | (1) | 5329 | 7203 | --- | --- |
| 66 | (1) | (1) | 8604 | 11,282 | --- | --- |
| 72 | (1) | (1) | (1) | (1) | --- | --- |

1. Consult your Emerson Process Management sales office for information.

Table 3 Approximate Weight for Size 3 through 24-Inch Valves

| VALVE SIZE | CLASS 600 | |
|------------|-------------|---------------|
| | Wafer Style | Single Flange |
| kg | | |
| 3 | 9 | 15 |
| 4 | 10 | 24 |
| 6 | 25 | 48 |
| 8 | 52 | 83 |
| 10 | 113 | 163 |
| 12 | 153 | 209 |
| 14 | 186 | 254 |
| 16 | 274 | 349 |
| 18 | 361 | 481 |
| 20 | 526 | 671 |
| 24 | 669 | 880 |
| lbs | | |
| 3 | 20 | 32 |
| 4 | 23 | 52 |
| 6 | 54 | 106 |
| 8 | 115 | 183 |
| 10 | 249 | 360 |
| 12 | 337 | 460 |
| 14 | 410 | 560 |
| 16 | 605 | 770 |
| 18 | 796 | 1060 |
| 20 | 1160 | 1480 |
| 24 | 1475 | 1940 |

Specifications

Specifications are shown in table 1 and the specifications for a given valve are stamped on a nameplate attached to the valve.

Installation

WARNING

Always wear protective gloves, clothing, and eyewear when performing any installation operations to avoid personal injury.

Check with your process or safety engineer for any additional measures that must be taken to protect against process media.

If installing into an existing application, also refer to the WARNING at the beginning of the Maintenance section in this instruction manual.

Note

When installing a valve after it has been in long-term storage, cycle the valve at least ten times to re-energize the dynamic seal.

Please contact your Emerson Process Management sales office if you have any questions about preparing a valve for storage or if you are planning to put into service a valve that has been stored for some time.

Adjusting the Travel Stops

CAUTION

When using manual or power actuators, adjust the actuator travel stops so the disc stop in the valve body does not absorb the output of the actuator.

For actuators without travel stops, the actuator must be properly mounted to prevent it from driving the valve disc against the valve disc travel stop.

Failure to limit actuator travel as described in this section can result in damage to the valve shafts or other valve parts.

Note

An "S" is visible on both the valve shaft and valve body. When the valve disc is closed, the "S" on the shaft aligns with the "S" on the valve body.

1. Locate the actuator travel stop that establishes the closed position of the valve disc. When adjusting the travel stop make sure that the disc is from 0 to 0.76 mm (0 to 0.030 inch) away from the internal stop in the valve body. This adjustment is necessary to be certain that the actuator output torque is fully absorbed by the actuator travel stop rather than the stop in the valve body.

For actuators without travel stops, the actuator must be properly mounted to prevent it from driving the valve disc against the valve disc travel stop.

A11 Valve

1. To mount an actuator without travel stops, first, if necessary, remove the actuator from the valve. Then, position the valve disc from 0 to 0.76 mm (0 to 0.030 inch) away from the internal stop in the valve body.
2. Now, travel the actuator to the maximum position. Keep the actuator in the maximum travel position. Return the actuator to the valve, taking care not to disturb the position of the valve disc.
3. Mount the actuator on the valve using proper bolts with locking washers to achieve a secure fit.
4. Before installing the valve/actuator assembly in the process line, cycle the valve several times to be sure the valve disc returns to the proper position.

Preparing for Installation



WARNING

If the Type A11 valve is equipped with a fail-open actuator, remove the actuator before installing the valve/actuator assembly or cycle the valve into the fully closed position. Then, to avoid possible personal injury or property damage, take appropriate steps to ensure that the actuator does not cause the valve to open during installation.

1. If the valve and actuator have been purchased separately or if the actuator has been removed for storage, travel stop adjustment, or maintenance, mount the actuator before inserting the valve/actuator assembly into the line. Refer to the actuator instruction manual for mounting and adjustment procedures.

CAUTION

To avoid product damage, inspect the valve before installation for any damage or any foreign material that may have collected in the valve body. Also remove any pipe scale, welding slag, or other foreign material from the pipeline.

2. Remove the protective end covers from the valve and inspect the valve body to be certain that it is free of foreign material. Also, be certain that adjacent pipelines are free of any foreign material, such as

pipe scale or welding slag that could damage the valve seating surfaces.



WARNING

The Type A11 valve is designed for use with the appropriate piping schedule for the ASME class. However, before putting the valve into operation, measure carefully to ensure disc rotation without interference from piping or flanges. Be certain to center the valve accurately to prevent interference of the disc with the flanges.

- The edges of a rotating disc have a shearing effect that may result in personal injury. To help prevent such injuries, stay clear of the disc edges when rotating the disc.
- Damage to the disc will occur if any pipe flanges or piping connected to the valve interfere with the disc rotation path. If the piping flange has a smaller inner diameter than specified for schedule 80 piping, measure carefully to be certain the disc rotates without interference before putting the valve into operation.

3. Select the appropriate gaskets for the application. flexible graphite, spiral wound, or other gasket types, made to ASME B16.5 group or user's standard, can be used on Type A11 valves depending on the service conditions of the application. Note: spiral wound gaskets, when properly centered, will cover more than 60 percent of the gasket area at the retaining ring screws.

For metal-seated and cryogenic valve gasket recommendations, please contact your Emerson Process Management sales office.

4. Refer to the appropriate table for the quantity and size of flange bolts required (table 4 or 5) and proceed with the following instructions.

Valve Orientation

Type A11 valve bodies are designed for installation with the shaft in any orientation around the pipeline: horizontal, vertical, or at an angle. However, when installing a Type A11 valve, please follow these recommendations.

Table 4. Stud Bolt and Cap Screw Data for Wafer Style Valves

| Class 150 & Class 150/150 | | | | |
|--------------------------------------|-----------|-----------|-----------|-----------|
| VALVE SIZE, INCHES | 30 | 36 | 42 | 48 |
| Number of Stud Bolts | 24 | 28 | 32 | 40 |
| Number of Cap Screws | 8 | 8 | 8 | 8 |
| Size-Diameter Inch - Thread | 1-1/4 - 8 | 1-1/2 - 8 | 1-1/2 - 8 | 1-1/2 - 8 |
| A-Length of Stud Bolts, Inch | 15-1/2 | 18 | 20-3/4 | 22-3/4 |
| B-Length of Cap Screw, Inch | 4-1/2 | 5-1/4 | 6 | 6-1/2 |

| Class 300 | | | | |
|------------------------------|-----------|--------|-----------|-----------|
| VALVE SIZE, INCHES | 30 | 36 | 42 | 48 |
| Number of Stud Bolts | 24 | 28 | 28 | 28 |
| Number of Cap Screws | 8 | 8 | 8 | 8 |
| Size-Diameter Inch - Thread | 1-3/4 - 8 | 2 - 8 | 1-5/8 - 8 | 1-7/8 - 8 |
| A-Length of Stud Bolts, Inch | 21-1/2 | 24-1/4 | 26 | 32 |
| B-Length of Cap Screw, Inch | 5-3/4 | 6-1/2 | 7-1/4 | 8 |

| Class 600 | | | | | | |
|------------------------------|-----------|-----------|-----------|-----------|-----------|-----------|
| VALVE SIZE, INCHES | 3 | 4 | 6 | 8 | 10 | 12 |
| Number of Stud Bolts | 8 | 8 | 12 | 12 | 12 | 16 |
| Number of Cap Screws | --- | --- | --- | --- | 8 | 8 |
| Size-Diameter Inch - Thread | 3/4 - 10 | 7/8 - 9 | 1 - 8 | 1-1/8 - 8 | 1-1/4 - 8 | 1-1/4 - 8 |
| A-Length of Stud Bolts, Inch | 7-1/4 | 8-1/2 | 10 | 11-1/2 | 13-1/2 | 14-3/4 |
| B-Length of Cap Screw, Inch | --- | --- | --- | --- | 4-1/4 | 4-1/2 |
| VALVE SIZE, INCHES | 14 | 16 | 18 | 20 | 24 | |
| Number of Stud Bolts | 15 | 16 | 16 | 20 | 20 | |
| Number of Cap Screws | 8 | 8 | 8 | 8 | 8 | |
| Size-Diameter Inch - Thread | 1-3/8 - 8 | 1-1/2 - 8 | 1-5/8 - 8 | 1-5/8 - 8 | 1-7/8 - 8 | |
| A-Length of Stud Bolts, Inch | 16 | 17-1/2 | 19 | 20-3/4 | 22-1/4 | |
| B-Length of Cap Screw, Inch | 4-1/2 | 5 | 5-1/2 | 5-3/4 | 6-1/4 | |

Table 5. Stud Bolt and Cap Screw Data for Single Flange Style Valves

| Class 150 & Class 150/150 | | | | |
|--------------------------------------|-----------|-----------|-----------|-----------|
| VALVE SIZE, INCHES | 30 | 36 | 42 | 48 |
| Number of Cap Screws | 56 | 64 | 72 | 88 |
| Size-Diameter Inch - Thread | 1-1/4 - 8 | 1-1/2 - 8 | 1-1/2 - 8 | 1-1/2 - 8 |
| B-Length of Cap Screw, Inch | 4-1/2 | 5-1/4 | 6-1/4 | 6-1/2 |

| Class 300 | | | | |
|-----------------------------|-----------|-------|-----------|-----------|
| VALVE SIZE, INCHES | 30 | 36 | 42 | 48 |
| Number of Cap Screws | 56 | 64 | 64 | 64 |
| Size-Diameter Inch - Thread | 1-3/4 - 8 | 2 - 8 | 1-5/8 - 8 | 1-7/8 - 8 |
| B-Length of Cap Screw, Inch | 5-3/4 | 6-1/2 | 6 | 8-1/4 |

| Class 600 | | | | | | |
|-----------------------------|-----------|-----------|-----------|-----------|-----------|-----------|
| VALVE SIZE, INCHES | 3 | 4 | 6 | 8 | 10 | 12 |
| Number of Cap Screws | 16 | 16 | 24 | 24 | 32 | 40 |
| Size-Diameter Inch - Thread | 3/4 - 10 | 7/8 - 9 | 1 - 8 | 1-1/8 - 8 | 1-1/4 - 8 | 1-1/4 - 8 |
| B-Length of Cap Screw, Inch | 2-1/2 | 3 | 3-1/2 | 4 | 4-1/4 | 4-1/2 |
| VALVE SIZE, INCHES | 14 | 16 | 18 | 20 | 24 | |
| Number of Cap Screws | 40 | 40 | 40 | 48 | 48 | |
| Size-Diameter Inch - Thread | 1-3/8 - 8 | 1-1/2 - 8 | 1-5/8 - 8 | 1-5/8 - 8 | 1-7/8 - 8 | |
| B-Length of Cap Screw, Inch | 4-1/2 | 5 | 5-1/2 | 5-3/4 | 6-1/4 | |

A11 Valve

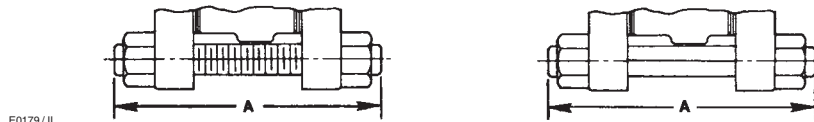

Figure 2. View of Stud Bolts

- In certain services (process fluids with high concentrations of entrained solids, abrasive slurries, or polymerizing media), valve performance will be enhanced by installing the valve with the shaft horizontal to the pipeline.

- Valves supplied for unidirectional shutoff should be installed with the high pressure at the back (waterway side) of the disc. A flow tag with an arrow is provided for proper installation.

The High Performance Butterfly Valve is designed to allow flow in either direction when in the open position. When in the closed position, high pressure should be applied to a specific side of the disc to provide best performance and optimal service life.

- Valves supplied for bidirectional shutoff, such as soft or Phoenix III, under normal operating conditions can (at different times) experience pressure in both directions; the highest of the two pressures should be exerted on the preferred side of the disc. If the two pressures are equal, then the one lasting the longest period of time should be applied to the preferred side. A flow tag with an arrow is provided for proper installation.

If you have questions about proper valve orientation in a specific application, contact your Emerson Process Management sales office.

Installing the Valve

WARNING

Always wear protective gloves, clothing, and eyewear when performing any installation operations to avoid personal injury.

To avoid personal injury or property damage resulting from the sudden release of pressure, do not install the valve assembly where service conditions could exceed the limits given in this manual, the limits on the appropriate nameplates, or the

matching pipe flange rating. Use pressure-relieving devices as required by government or accepted industry codes and good engineering practices.

Check with your process or safety engineer for any additional measures that must be taken to protect against process media.

If installing into an existing application, also refer to the WARNING at the beginning of the Maintenance section in this instruction manual.

CAUTION

When ordered, the valve configuration and construction materials were selected to meet particular pressure, temperature, pressure drop, and controlled fluid conditions. Responsibility for the safety of process media and compatibility of valve materials with process media rests solely with the purchaser and end-user. Since some valve/body trim material combinations are limited in their pressure drop and temperature ranges, do not apply any other conditions to the valve without first contacting your Emerson Process Management sales office.

For Wafer Style Valves:

1. See figure 3. Install the lower flange bolts first to form a cradle for the valve.
2. Properly orient the valve according to the specific application. Be sure the valve is placed in the line so the flow properly enters the valve. Then, install the valve and the gaskets between the flanges into the cradle formed by the flange bolts.
3. Install the remaining flange bolts, making sure that the gaskets are centered on the gasket sealing surfaces of the flange and valve body.
4. Tighten the flange bolts in an alternating criss-cross fashion to a torque value of one-fourth of

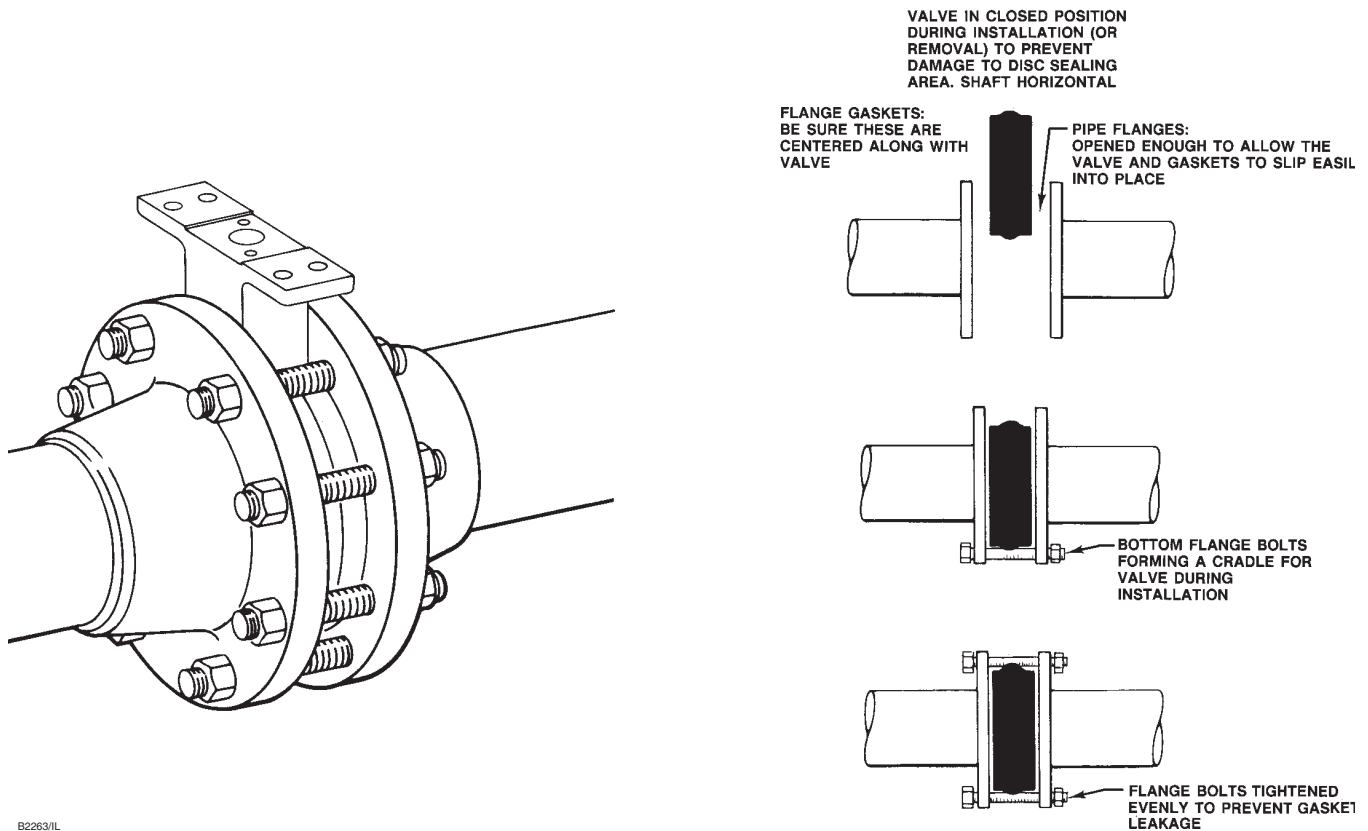

Figure 3. Proper Installation Procedure

the final bolting torque. Repeat this procedure several times increasing the torque value each time by a fourth of the final desired torque. When the final torque value has been applied, tighten each flange bolt again to allow for gasket compression.

For Single Flange Valves:

1. Position the valve between the flanges. Be sure to leave enough room for the flange gaskets; then install the lower flange bolts.
2. Install the gaskets and align the valve and the gaskets.
3. Install the remaining bolts.
4. Tighten the flange bolts in an alternating criss-cross fashion to a torque value of one-fourth of the final bolting torque. Repeat this procedure several times increasing the torque value each time by a fourth of the final desired torque. When the final torque value has been applied, tighten each flange bolt again to allow for gasket compression.

Thrust Washers

Two thrust washers are used in valve sizes 10-inch and larger (Class 150), 8-inch and larger (Class 300), 8-inch and larger (Class 600). The thrust washers are located at the upper and lower bearing areas of the valve. Thrust washers must be installed before the disc is installed in the valve body.

Packing Adjustment and Shaft Bonding

WARNING

Personal injury could result from packing leakage. Valve packing was tightened before shipment; however, the packing might require some readjustment to meet specific service conditions. Check with your process or safety engineer for any additional measures that must be taken to protect against process media.

1. For PTFE or graphite packing: Tighten standard packing follower nuts only enough to

A11 Valve

prevent shaft leakage. Excessive tightening of packing will accelerate wear and could produce higher rotating friction loads on the valve shaft. If necessary, refer to the Packing Maintenance section.

2. **For ENVIRO-SEAL Packing Systems:** These packing systems will not require this initial re-adjustment. Refer to the separate ENVIRO-SEAL Packing System for Rotary Valves Instruction Manual, Form 5305 for repair and adjustment procedures.

3. For hazardous atmosphere or oxygen service valves, read the following **Warning**, and provide the bonding strap assembly mentioned below if the valve is used in an explosive atmosphere.

WARNING

The valve drive shaft is not necessarily grounded to the pipeline when installed. Personal injury or property damage could result, if the process fluid or the atmosphere around the valve is flammable, from an explosion caused by a discharge of static electricity from the valve components. If the valve is installed in a hazardous area, electrically bond the drive shaft to the valve body.

Note

The packing is composed of all conductive packing rings (graphite ribbon packing) or partially conductive packing rings (carbon-filled PTFE female adaptor with PTFE V-ring packing or graphite-composition packing ring with PTFE/composition packing) to electrically bond the shaft to the valve for hazardous area service. For oxygen service applications, and hazardous area service where the standard packing doesn't provide sufficient shaft-to-valve body bonding, provide alternate shaft-to-valve body bonding according to the following step.

4. Attach the bonding strap assembly (key 131, figure 4) to the shaft with the clamp (key 130, figure 4).

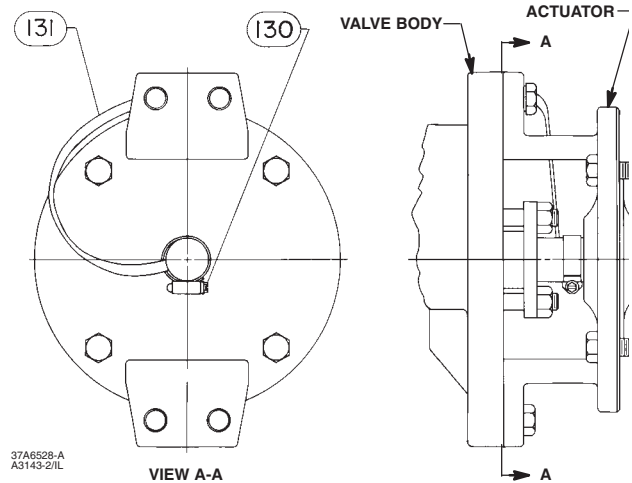

Figure 4. Optional Shaft-to-Body Bonding Strap Assembly

5. Connect the other end of the bonding strap assembly to the valve flange cap screws.

6. For more information, refer to the Packing Maintenance section below.

Maintenance

Valve parts are subject to normal wear and must be inspected and replaced as necessary. The frequency of inspection and replacement depends upon the severity of service conditions.

WARNING

Avoid personal injury from sudden release of process pressure. Before performing any maintenance operations:

- Disconnect any operating lines providing air pressure, electric power, or a control signal to the actuator. Be sure the actuator cannot suddenly open or close the valve.

- Use bypass valves or completely shut off the process to isolate the valve from process pressure. Relieve process pressure on both sides of the valve. Drain the process media from both sides of the valve.

- Vent the power actuator loading pressure.

- Use lockout procedures to be sure the above measures stay in effect while you work on the equipment.
- Always wear protective gloves, clothing and eyewear when performing any maintenance operations to avoid personal injury.
- The valve packing area may contain process fluids that are pressurized, *even when the valve has been removed from the pipeline.* Process fluids may spray out under pressure when removing the packing hardware or packing rings.
- Check with your process or safety engineer for any additional measures that must be taken to protect against process media.

CAUTION

When using an actuator, the actuator travel stop (or actuator, for actuators without adjustable stops) must be adjusted so the disc stop in the valve does not absorb the output of the actuator. Failure to limit the actuator travel can result in damage to the valve, shaft(s), or other valve components.

Removing the Valve

For field repair, remove the valve from the pipeline.



WARNING

Using the procedures listed in the above WARNING, loosen the flange bolting that holds the valve. Make sure the valve cannot slip or twist while the bolting is being loosened and removed.

CAUTION

Damage to the disc can occur if the disc is not closed when the valve is being removed from the pipeline. If

necessary, stroke the actuator to place the disc in the closed position while removing the valve from the pipeline.

7. Before removing the valve from the pipeline, make sure the valve disc is closed. See figure 3. Rotate the shaft clockwise until the disc makes contact with the internal stop or actuator travel stop (if still installed). The "S" stamped on the shaft should be aligned with the "S" on the valve body.
8. After removing the valve from the pipeline, move it to an appropriate work area. Remove the actuator from the valve.

Packing Maintenance

The Type A11 valve is designed so the shaft packing can be replaced without removing the valve from the process pipeline. Refer to figure 8 for available packing configurations and figure 9 for part key numbers.

CAUTION

The packing flange should be tightened only enough to prevent shaft leakage. Excessive tightening will only accelerate wear of the packing and could produce higher torques on the valve.

In most cases, packing leakage can be eliminated by merely tightening the hex nuts located above the packing flange while the valve is in the pipeline. However, if leakage continues, the packing must be replaced.

1. Before loosening any parts on the valve, be sure the pipeline has been depressurized. Then, remove packing nuts (key 16), lift off the packing flange (key 12) and packing follower (key 13). The packing (key 14) is now accessible.
2. Use a packing extractor to remove packing. Insert the corkscrew-like end of the tool into the first piece of packing and firmly remove. Repeat this process until all has been removed.

CAUTION

Be careful when cleaning the packing bore. Scratches to the valve shaft (key 4) or inside diameter of packing bore may cause leakage.

A11 Valve

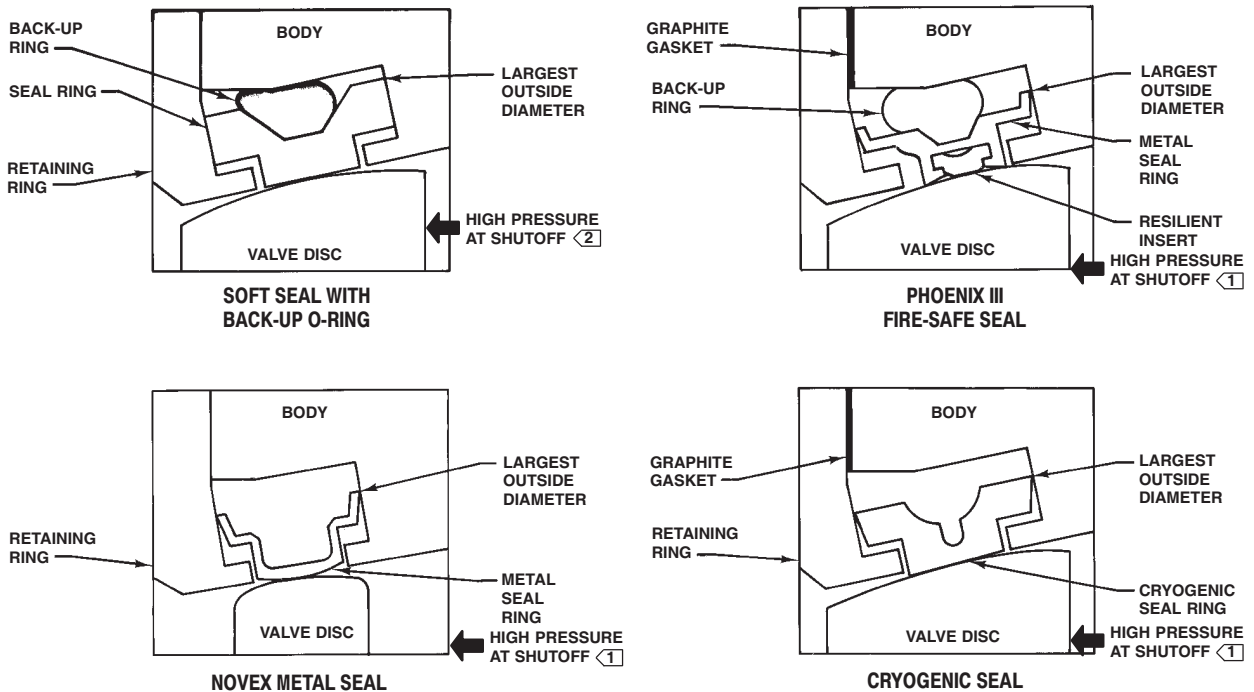

NOTES:

- ① THIS UNIDIRECTIONAL SEAL MUST BE INSTALLED SO THAT THE RETAINING RING IS DOWNSTREAM FROM THE HIGH PRESSURE SIDE OF THE VALVE AT SHUTOFF, AS SHOWN.
- ② FOR THIS BIDIRECTIONAL SEAL, THE "PREFERRED" VALVE ORIENTATION PLACES THE RETAINING RING DOWNSTREAM FROM THE HIGH PRESSURE SIDE OF THE VALVE AT SHUTOFF.

E0578 / IL

Figure 5. Seals

3. Before installing new packing, clean the packing bore.
4. Install new packing one ring at a time, using the packing follower as a driver. If split packing is used, stagger seams every 90°.
5. Reinstall the packing follower and packing flange, secure nuts, and tighten as needed.

Lantern Rings

Valves only have lantern rings if they are provided with purge fittings or lubrication fittings. Lantern rings are located either at the bottom of the packing or central packing area as noted in figure 8.

Lubrication Fittings and Purge Connectors

These connections and/or fittings are located on the lower gasket retainer and packing area of valve

bodies. They are normally either 1/8 inch NPT or 1/4 inch NPT.

Seal Maintenance

1. After the valve has been removed from the line and the manual or power actuator has been removed, manually rotate the shaft (key 4) counter-clockwise until the disc has moved a full 180°. Note that the "S" on the shaft is 180° from the "S" on the valve body.
2. Lay the valve flat on a work bench in a secure position with the retaining ring (key 2) and retaining ring screws (key 22) facing up. Use blocks or other appropriate techniques to support the valve. Remove all retaining ring screws.
3. Remove the retaining ring by placing a retaining ring screw in each of the two retaining ring jack screw holes. With the appropriate tool, slowly rotate the screws until the retaining ring has been lifted from the valve body.

CAUTION

In the following step, use the appropriate tool to avoid damage to the seal or T-slot area of the valve.

4. Different valve types have different seal designs and components. To see the appropriate seal, refer to figure 5. Insert the appropriate tool under the top edge of seal and gently pry the seal out. Take care not to damage the seal or T-slot area of the valve body. After the seal has been removed, clean the T-slot area, retaining ring and, if required, polish the disc thoroughly with fine steel wool or other appropriate material.

Soft Seal Installation

1. Locate the replacement seal ring (key 8) and note the shape of the ring. The ring is wider across one edge diameter and narrower across the other edge diameter as shown in figure 6. Around the outside circumference is one wide groove.

Before installing the seal ring into the valve body, the backup ring (key 9) must first be placed onto the wide, outer groove of the seal ring.

2. The seal ring and backup ring assembly must be installed in the valve. The wider outside diameter of the seal ring goes into the T-slot area of the valve body, shown in figure 7. Start the wider diameter edge of the seal ring into the T-slot of the valve body using a blunt end screwdriver.

3. Carefully tuck the backup ring downward into the valve body T-slot until the seal ring and back-up ring are completely entrapped in the valve body T-slot.

4. When the seal is thoroughly seated, re-install the retaining ring and screws. Tighten the retaining screws just enough to eliminate vertical movement of the retaining ring. With the use of the blunt end tool, carefully tuck the lip of the seal ring under the retaining ring.

5. When the seal is under the lip of the retaining ring, tighten the screws according to standard procedures. Manually rotate the valve shaft clockwise 180° to return the disc to its closed position against the internal stop.

6. The final seating of the retaining ring screws can now be done. For the screw torque values, refer to table 6. The seal is now fully installed and the valve may be closed for installation or storage.

Metal and Phoenix III Seal Installation

For metal seal installation:

Locate the replacement seal ring (key 8) and note the shape of the ring. The ring is wider across one edge diameter and narrower across the other edge diameter as shown in figure 6. Around the outside circumference is one wide groove.

Install the seal ring (key 8) into the valve body by first placing the wider outside diameter of the seal ring into the T-slot area of the valve body which is shown in figure 7. Metal seals without a back-up ring will fall into place. Metal seals with a back-up ring (key 9) will have to be installed following the instructions given below for the Phoenix III seal with back-up ring.

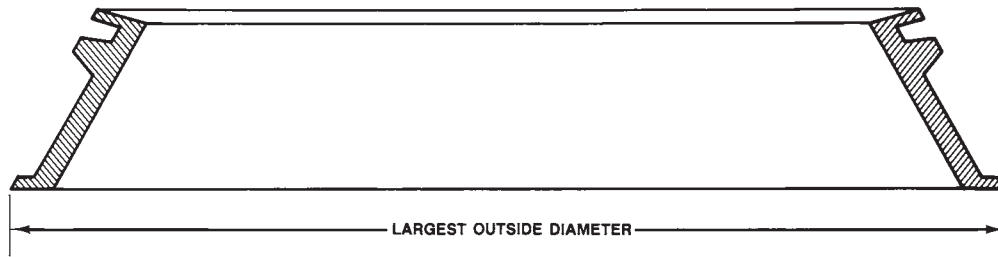

Figure 6. Typical Seal Ring (Sectional)

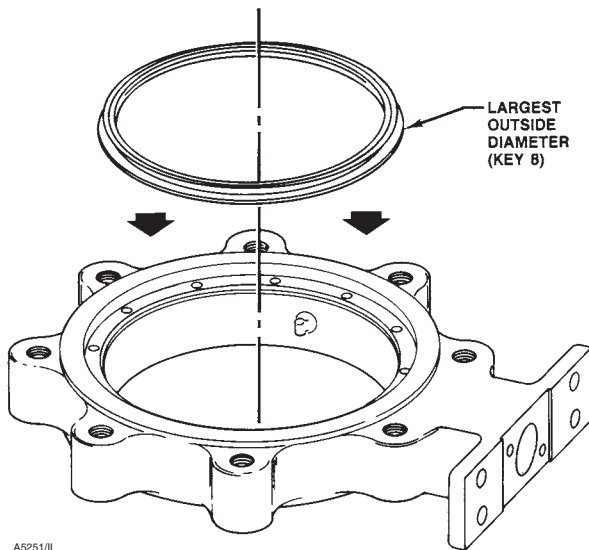

Figure 7. Typical Seal Installation

For Phoenix III seal installation:

1. Locate the replacement seal ring (key 8) and note the shape of the ring. The ring is wider across one edge diameter and narrower across the other edge diameter as shown in figure 6. Around the outside circumference is one wide groove.

Install the seal ring in the valve body by first placing the wider outside diameter of the seal ring, as marked in figure 6, into the T-slot area of the valve body which is shown in figure 7. Phoenix III seal rings without a back-up ring will fall into place. If the Phoenix III seal uses a back-up ring (key 9), the back-up ring will have to be installed after placing the seal ring in the valve using a blunt end screwdriver. Do not use the screwdriver or seal tool directly on the metal seat. Use a tool only on the backup ring.

2. With the seal ring inserted all the way around the valve body T-slot now lay the backup ring into the

opening between the valve body and the seal ring. Use the seal tool to apply pressure to the backup ring and carefully tuck the backup ring down into the T-slot between the valve body and the seal ring. Note: On larger valves, it may be more efficient to have someone hold down the seal ring while the backup ring is pushed into the T-slot.

3. Once the seal ring or seal and backup ring has been fully installed into the valve body T-slot, the retaining ring gasket (key 17) can be installed.

CAUTION

This gasket is a thin graphite material. Take care to avoid damaging the gasket. However, punch one initial screw hole through the gasket for alignment purposes.

4. Install the retaining ring and align the screw holes in the retaining ring with the holes in the valve body. Install the first retaining ring screw through the punched hole in the ring gasket. Install the other ring screws by pushing the screws through the graphite gasket and threading them into valve body.

5. Tighten the retaining ring screws just enough to eliminate vertical movement of the retaining ring. Do not tighten the retaining ring screws.

WARNING

Avoid personal injury or property damage caused by the impact of a falling or tipping large valve. Large valves must be properly supported during maintenance.

6. To complete this step, stand the valve up. Support the valve securely using methods appropriate for the valve size.

CAUTION

If a vise or other clamps are being used, be sure damage is not done to the flange gasket sealing area of the valve body.

7. Manually rotate the valve shaft to turn the disc clockwise to meet the seal.

8. Tap the disc with a rubber mallet to drive it against the internal travel stop. When the disc makes contact with the stop, manually rotate the disc counter-clockwise back out of the seal to a 90° open position. Repeat steps 7 and 8 three times.

9. The final seating of the retaining ring screws can be done. For the screw torque values, refer to table 6. The seal is now fully installed and the valve may be closed for installation or storage.

Cryogenic Seal Installation

1. Locate the replacement seal ring (key 8) and note the shape of the ring. The ring is wider across one edge diameter and narrower across the other edge diameter as shown in figure 6. Around the outside circumference is one wide groove.

For Kel-F seals with aluminum backup rings

only: Now, locate the replacement V-ring. Please notice that the V-ring is similar in diameters to the seal ring. Place the V-ring down onto the seal ring with the larger diameter of the V-ring going first. Be sure the larger diameters on both rings are down.

2. **For all types:** Install the seal ring (or seal ring and V-ring) in the valve body by first placing the wider outside diameter of the seal ring into the T-slot area of the valve body. The seal ring with or without a back-up ring will fall into place.

3. Once the seal ring (or seal ring and V-ring) have been fully installed into the valve body T-slot, the retaining ring gasket can be installed.

CAUTION

This gasket is a thin graphite material. Take care to avoid damaging the gasket. However, punch one initial screw hole through the gasket for alignment purposes.

4. Install the retaining ring and align the screw holes in the retaining ring with the holes in the valve body. Install the first retaining ring screw through the punched hole in the ring gasket. Install the other ring screws by pushing the screws through the graphite gasket and threading them into the screw holes in the valve body.

5. Tighten the retaining ring screws just enough to eliminate vertical movement of the retaining ring. Do not tighten the retaining ring screws.

 **WARNING**

Avoid personal injury or property damage caused by the impact of a falling or tipping large valve. Large valves must be properly supported during maintenance.

6. To complete this step, stand the valve up. Support the valve securely using methods appropriate for the valve size.

CAUTION

If a vise or other clamps are being used, be sure damage is not done to the flange gasket sealing area of the valve body.

7. Manually rotate the valve shaft to turn the disc clockwise to meet the seal.

8. Tap the disc with a rubber mallet to drive it against the internal travel stop. When the disc makes contact with the stop, manually rotate the disc counter-clockwise back out of the seal to a 90° open position. Repeat steps 7 and 8 three times.

9. The final seating of the retaining ring screws can be done. For the screw torque values, refer to table 6. The seal is now fully installed and the valve may be closed for installation or storage.

Valve Shaft/Disc Pin Unit Maintenance

Valve Shaft/Disc Pin Unit Removal

1. Rotate the disc (key 3) 180° counterclockwise from the full closed position.

2. Place the open valve horizontally on a suitable work surface with the retaining ring (key 2) facing upward. Be sure to properly support the valve with blocks while the shaft is being removed.

THE FOLLOWING PACKING CONFIGURATIONS ARE AVAILABLE FOR SPECIFIC APPLICATIONS:

CODE 1 - PTFE - STD. ON CLASS 150 AND 300 SOFT SEATED AND CRYOGENIC VALVES

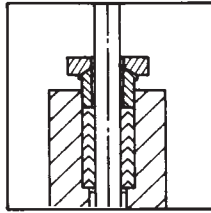

STD. "V" TYPE PACKING

CODE 5 - GRAPHITE
CODE 6 - PTFE

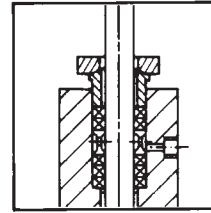

STD. SQ. TYPE JAM PACKING WITH LANTERN RING/BLEED-OFF CONNECTION

CODE 2 - GRAPHITE - STD. ON METAL SEATED, AND FIRE-SAFE VALVES
CODE 3 - PTFE - STD. ON CLASS 600 AND UP SOFT SEATED VALVES

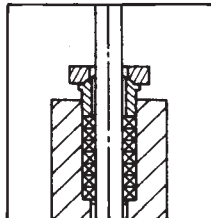

STD. SQ. TYPE JAM PACKING

CODE 7 - GRAPHITE
CODE 8 - PTFE

TO BE USED WHEN BEARING GREASE CONNECTIONS ARE REQUIRED.

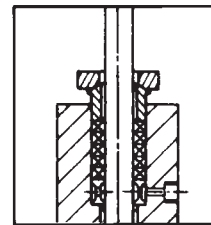

STD. SQ. TYPE JAM PACKING WITH LANTERN RING/BEARING LUBRICATION CONNECTION

CODE 4 - PTFE

TO BE USED IN VACUUM SERVICE BELOW 20 MICRONS

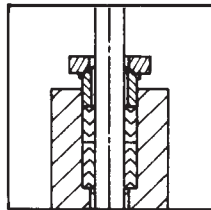

STD. REVERSE "V" TYPE PACKING

A5249/IL

Figure 8. Packing Configurations

Note

The disc must be removed from the waterway side of the valve body, which is the side opposite the T-slot area. Support the valve and disc so the disc can be easily removed from the valve when the shaft is removed.

3. Use a pin extractor to remove the disc pins (key 6). Select the proper pin extractor tip with screws of proper thread size to match the thread size in the disc pins.
4. Screw the pin extractor tip into the pin as far as possible. With an upward, straight sliding motion, extract the pin. Repeat the same procedure for the other pins.

A threaded rod with an appropriate spacer and nut can also be used as an extractor tool. If using a threaded rod, choose a rod with threads that fit the inside threads of the pins. The rod should extend

several inches above the disc when screwed into a pin.

5. After screwing the rod into the pin, slide the spacer over the rod and pin. Thread the nut onto the rod and tighten. As the nut is tightened, it will drive the spacer against the disc and the increasing pressure will draw the pin from the disc.
6. Loosen the packing nuts (key 16).
7. Extract the shaft (key 4) by hand-pulling or by using the pin extractor screwed into the end of the shaft.

Note

Valves with a two-piece shaft use a gasket retainer, which must be removed before removing the lower shaft.

Table 6. Torque Values for Fasteners

| Fastener Nominal Size | N•m | In•lb | Ft•lb |
|-----------------------|-----|-------|-------|
| #10 | 4 | 35 | --- |
| 1/4 | 9 | 81 | --- |
| 5/16 | 19 | 167 | --- |
| 3/8 | 33 | 295 | --- |
| 7/16 | 53 | --- | 39 |
| 1/2 | 80 | --- | 59 |
| 9/16 | 117 | --- | 86 |
| 5/8 | 161 | --- | 119 |
| 3/4 | 286 | --- | 211 |
| 7/8 | 447 | --- | 330 |
| 1 | 651 | --- | 480 |
| 1-1/8 | 837 | --- | 617 |

CAUTION

In the following step, remove the disc from the waterway side of the valve to avoid damage to the disc or T-slot area of the valve.

8. Remember: the disc must be removed from the waterway side of the valve. Do not try to force the disc through the seal side of the valve. This could cause severe damage to the disc and T-slot area.

After removing the shaft, remove the disc.

Valve Shaft/Disc Pin Unit Installation

Note

Replacement disc and shaft(s) are provided as a matched set. When replacing either the disc or shaft(s), a matched set is required.

To replace the disc pin assembly (key 6), reverse the removal steps used above.

Before placing disc into a valve body, properly align the top of the disc with the top of the valve. A "T" is stamped on the disc to indicate alignment. Be sure holes in the shaft are exactly aligned with the holes in the disc before re-installing pins. After pins are fully seated in the disc, use a punch or small chisel to stake the pins at three points. This will prevent the pins from working free and out of the disc due to vibration.

Gasket Retainer

When two-piece shafts are used, a gasket retainer assembly must be used. The gasket is held in place by a gasket retainer and four hex head bolts and lockwashers. When re-assembling the valve, this gasket should always be replaced. Be sure the gasket is centered over the shaft bore before retightening bolts. Tighten down bolts evenly in a cross over pattern or in a star pattern. Refer to table 6 for proper torque values.

Bearing Maintenance

Bearing Removal

To get access to the bearings (key 10), the disc and shaft assembly (keys 3, 4 and 5) must be removed from the valve. The bearings (key 10) may be removed by using a brass drift punch and lightly tapping them out. In valves without lower bonnets, the lower bearing is removed by grasping it and pulling upwards. Also, cryogenic valves have an outboard bearing under the packing. Refer to the Packing Maintenance section for instructions.

Bearing Installation

Before installation of the bearings, bearing bores should be solvent cleaned and bearings will slip in.

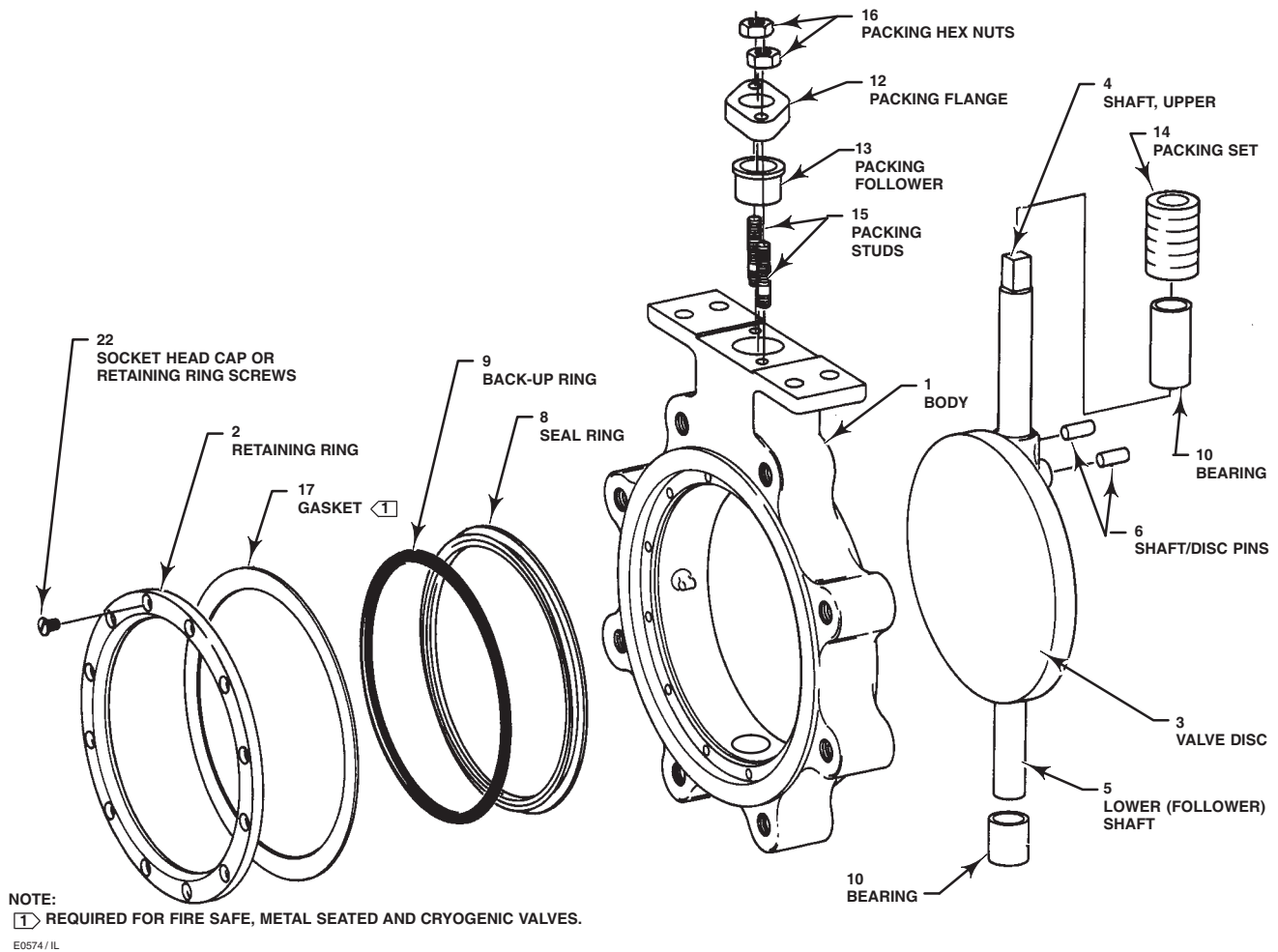

Figure 9. Typical Type A11 Valve Assembly

Parts Ordering

When corresponding with your Emerson Process Management sales office about a Type A11 valve, please mention the valve serial number which is stamped on the nameplate and the part number from the following list.



WARNING

Use only genuine Fisher® replacement parts. Components that are not supplied by Emerson Process Management should not, under any

circumstances, be used in any Fisher valve, because they will void your warranty, might adversely affect the performance of the valve, and could give rise to personal injury and property damage.

Note

Neither Emerson, Emerson Process Management, nor any of their affiliated entities assumes responsibility for the selection, use and maintenance of any product. Responsibility for the selection, use, and maintenance of any product remains with the purchaser and end-user.

Parts List

All items listed as being 3 through 24-inch are for the Class 600 valves only. The 30 through 48-inch items are for 150/150, 150 or 300 Class valves, as specified.

Note

Part numbers are shown for recommended spares only. For other part numbers, contact your Emerson Process Management sales office.

| Key | Description | Part Number |
|-----|---|---------------------|
| 1 | Valve Body If you need a valve body as a replacement part, order the valve size, Class, serial number, and desired material. Contact your Emerson Process Management sales office. | |
| 2 | Retaining Ring | |
| 7* | Key (Not Shown) | |
| | 6-inch | V116663X012 |
| | 8- & 10-inch | V116663X012 |
| | 12-inch | V116197X012 |
| | 30- & 36- inch Class 150/150 | V171330X012 |
| | 42-inch Class 150/150, 30-, 36- & 48-inch Class 150 & 30-inch Class 300 | 13B2601X012 |
| | 36-inch Class 300 | 13B3422X012 |
| | 42-inch Class 150 | V148564X012 |
| | 42-inch Class 300 | V178488X012 |
| 8* | Seal Ring | See following table |
| 9 | Back-up Ring | |
| 10* | Bearing | See following table |
| 11* | Thrust Bearing (Not Shown) | See following table |
| 12 | Packing Flange | |
| 13 | Packing Follower | |
| 14* | Packing Set | See following table |
| 15 | Stud | |
| 16 | Hex Nut | |
| 17* | Gasket (Retainer Ring) w/Metal and Phoenix III Seals | |
| | 3-inch | V163883X012 |
| | 4-inch | V164130X012 |
| | 6-inch | V163884X012 |
| | 8-inch | V168656X022 |
| | 10-inch | V164111X012 |
| | 12-inch | V164217X012 |
| | 14-inch | V164128X012 |
| | 16-inch | V164218X012 |
| | 18-inch | V164129X012 |
| | 20-inch | V163952X012 |

| Key | Description | Part Number |
|-------|---|---------------------|
| 17* | Gasket (Retainer Ring) w/Metal and Phoenix III Seals (cont) | |
| | 24-inch | V164220X012 |
| | 30-inch Class 150 | V168292X012 |
| | 30-inch Class 150/150 | V124868X012 |
| | 30-inch inch Class 300 | V124882X012 |
| | 36-inch Class 150 & 150/150 | V124869X012 |
| | 36-inch Class 300 | V124883X012 |
| | 42-inch Class 150 & 150/150 | V124872X012 |
| | 42-inch Class 300 | V124881X012 |
| | 48-inch Class 150 & 150/150 | V125088X012 |
| | 48-inch Class 300 | V124874X012 |
| | Oxygen Service | |
| | 3-inch | V163883X022 |
| | 4-inch | V164130X022 |
| | 6-inch | V163884X022 |
| | 8-inch | V168656X012 |
| | 10-inch | V164111X022 |
| | 12-inch | V164217X022 |
| | 14-inch | V139619X042 |
| | 16-inch | V164218X022 |
| | 30-inch Class 150 | V168292X022 |
| | 30-inch Class 150/150 | V124868X022 |
| | 30-inch Class 300 | V124882X022 |
| | 36-inch Class 150 & 150/150 | V124869X022 |
| | 36-inch Class 300 | V124883X022 |
| | 42-inch Class 150 & 150/150 | V124872X022 |
| | 42-inch Class 300 | V142881X022 |
| | 48-inch Class 150 & 150/150 | V125088X022 |
| | 48-inch Class 300 | V124874X022 |
| 18* | Gasket Retainer (Not Shown) | |
| | 8-inch | V112278X012 |
| | 10-inch | V110620X012 |
| | 12-inch | V110621X012 |
| | 30 & 36-inch | V111679X012 |
| | 42-inch | V139469X012 |
| | 48-inch | V121625X012 |
| 19* | Retainer Gasket (not shown) | See following table |
| 20 | Lockwasher, retaining ring assembly S31600 | |
| 20 | Lockwasher, packing assembly | |
| 21 | Hex Head Bolt (Not Shown) | |
| 22 | Socket Head Cap or Retaining Ring Screws | |
| 24 | Nameplate (Not shown) | |
| 26 | Packing Spacer (Not shown) | |
| 27 | Drive Screw (Not Shown) | |
| 28* | Disc/Shaft Assembly | See following table |
| 29 | Label | |
| 33 | Flow Arrow (Not Shown) | |
| - - - | Line Bolting | |

A11 Valve

ENVIRO-SEAL® Packing Parts

Parts shown are used in standard and NACE constructions.

| | | |
|------|------------------------|-------------|
| 100 | Stud | |
| 101 | Hex Nut | |
| 102 | Packing Flange | |
| 103 | Spring Pack | |
| 105* | Packing Set | |
| | Use w/PTFE packing | |
| | 3-inch | 12B9122X012 |
| | 4-inch | 12B7414X012 |
| | 6-inch | 12B9078X012 |
| | 8-inch | 12B7462X012 |
| | 10-inch | 13B9155X012 |
| | 12-inch | 14B3647X012 |
| | 14-inch | 12B7782X012 |
| | 16-inch | 14B5652X012 |
| | 18-inch | 14B5730X012 |
| | Use w/Graphite packing | |
| | 3-inch | 13B8816X022 |
| | 4-inch | 13B8816X052 |
| | 6-inch | 13B8816X102 |
| | 8-inch | 13B8816X142 |
| | 10-inch | 14B3541X032 |
| | 12-inch | 14B3541X052 |
| | 14-inch | 14B3541X042 |
| | 16-inch | 14B3541X062 |
| | 18-inch | 14B3541X072 |

| Key | Description | Part Number |
|------|---|-------------|
| 106* | Anti-Extrusion Ring (2 req'd) Use w/PTFE packing | |
| | 3-inch | 12B9121X012 |
| | 4-inch | 12B7418X012 |
| | 6-inch | 12B9084X012 |
| | 8-inch | 12B7466X012 |
| | 10-inch | 13B9159X012 |
| | 12-inch | 14B3642X012 |
| | 14-inch | 12B7783X012 |
| | 16-inch | 14B5656X012 |
| | 18-inch | 14B5734X012 |
| 107 | Packing Box Ring | |
| 111 | Tag | |
| 112 | Cable Tie | |
| 113 | Lubricant | |

Instruction Manual

Form 5338
February 2007

A11 Valve

Key 8* Seal Ring

| VALVE SIZE, INCHES | CLASS | MATERIAL | | | |
|-----------------------|---------|-------------|------------------------|----------------------------------|---|
| | | ETFE | Metal Seal Ring S31600 | Metal Seal Ring S17400 H1150M | Phoenix III Metal Seal Ring |
| 3 | 600 | V111012X012 | V110605X012 | V110605X022 | V114478X012 |
| 4 | | V111035X012 | V149609X012 | V149609X022 | V114480X012 |
| 6 | | V118868X012 | V118864X012 | V118864X022 | V119985X012 |
| 8 | | V111037X012 | V141699X012 | V141699X022 | V142361X012 |
| 10 | | V111038X012 | V148798X012 | V148798X022 | V143266X012 |
| 12 | | V111039X012 | V149262X012 | V149262X022 | V143160X012 |
| 14 | | V111979X012 | V111992X012 | V111992X022 | V114495X012 |
| 16 ⁽¹⁾ | | V130804X012 | V135726X012 | --- | V149048X012 |
| 18 | | V111985X012 | V149399X012 | V149399X022 | V114501X012 |
| 20 | | V111988X012 | V111995X012 | V111995X022 | V149319X012 |
| 24 | | V111991X012 | V111996X012 | V111996X022 | V114509X012 |
| 42 | | 150/150 | --- | 13B1554X012 | --- |
| 42 | 150 | --- | 13B1571X012 | --- | --- |
| 48 | 150/150 | --- | 13B1555X012 | --- | --- |
| 48 | 150 | --- | 13B1572X012 | --- | --- |
| VALVE SIZE, INCHES | CLASS | MATERIAL | | | |
| | | PTFE | NOVEX | Phoenix III Metal Seal Ring | Phoenix III Metal Seal Ring for Oxygen Service |
| 30 | 150/150 | V113145X012 | V161260X012 | V114471X012 | V114471X022 |
| 30 | 150 | V113350X012 | V159048X022 | V114472X012 | V114472X022 |
| 30 | 300 | V113353X012 | 13B2252X042 | V114473X012 | V114473X022 |
| 36 | 150/150 | V113355X012 | V143195X012 | V114474X012 | V114474X022 |
| 36 | 150 | V113358X012 | V159051X012 | V143197X012 | V143197X012 |
| 36 | 300 | V113361X012 | 13B3645X012 | V141335X012 | V141335X022 |
| 42 | 150/150 | V130753X012 | --- | V126141X012 | V126141X022 |
| 42 | 150 | V130775X012 | --- | V127525X012 | V127525X022 |
| 42 | 300 | V130093X012 | --- | V130184X012 | V130184X022 |
| 48 | 150/150 | V130772X012 | --- | V119520X012 | V119520X022 |
| 48 | 150 | V136069X012 | --- | V129715X012 | V129715X022 |
| 48 | 300 | V130445X012 | --- | 13B2032X012 | 13B2032X022 |

1. The part number for 16-inch, Metal Seal Ring – S31600/ETFE is V161370X012

A11 Valve

Keys 10* and 11* Bearing and Thrust Bearing

| VALVE SIZE, INCHES | CLASS | QUANTITY | BEARING MATERIAL | | | |
|------------------------------|---------|----------|------------------|--------------|-------------|-------------|
| | | | PEEK | S31600 | Bronze | Alloy 6 |
| Key 10 Bearing | | | | | | |
| 3 | 600 | 3 | 13B1509X012 | V110614X022 | V110614X022 | V110614X042 |
| 4 | | 3 | 13B1660X012 | V166684X012 | V166684X032 | V166684X052 |
| 6 | | 3 | 13B1489X012 | V168505X012 | V168505X022 | V168505X052 |
| 8 | | 4 | 13B1851X012 | V174342X012 | V174342X022 | V174342X042 |
| 10 | | 4 | 13B1738X012 | V110616X012 | V110616X022 | V110616X042 |
| 12 | | 4 | V168186X012 | V171724X012 | V171724X032 | V171724X042 |
| 14 | | 4 | V168187X012 | V170455X012 | V170455X032 | --- |
| 16 | | 4 | V168188X012 | V1316999X052 | V131699X032 | --- |
| 18 | | 4 | V168189X012 | V131703X042 | V131703X052 | --- |
| 20 | | 6 | 13B1973X012 | V112012X012 | V112012X022 | --- |
| 24 | | 4 | 13B2776X012 | V112014X012 | V112014X022 | --- |
| 30 | | 150/150 | 4 | V127742X032 | 13B1585X012 | V127742X042 |
| 30 | 150 | 4 | V167654X012 | V171363X012 | V131010X012 | V131010X042 |
| 30 | 300 | 4 | 13B1968X012 | V175126X012 | V175126X032 | V175126X042 |
| 36 | 150/150 | 4 | 13B1969X012 | V176032X012 | V176032X032 | V176032X022 |
| 36 | 150 | 4 | 13B1970X012 | V171361X012 | V171361X032 | V171361X052 |
| 36 | 300 | 4 | 13B1971X012 | V174912X042 | V174912X032 | V174912X012 |
| 42 | 150/150 | 4 | 13B1972X012 | V114716X012 | V114716X022 | V114716X052 |
| 42 | 150 | 6 | 13B1973X012 | V112012X012 | V112012X022 | V112012X052 |
| 42 | 300 | 6 | 13B1974X012 | V130181X012 | V130181X042 | V130181X032 |
| 48 | 150/150 | 6 | 13B1768X012 | V171361X012 | V171361X032 | V171361X052 |
| 48 | 150 | 4 | 13B1975X012 | V171365X012 | V171365X032 | V171365X052 |
| 48 | 300 | 10 | 13B1976X012 | V117028X012 | V117028X042 | V117028X032 |
| Key 11 Thrust Bearing | | | | | | |
| 8 | 600 | 2 | 13B1850X012 | V174343X012 | V174343X022 | V174343X052 |
| 10 | | 2 | 13B1739X012 | V110446X012 | V110446X022 | V110446X042 |
| 12 | | 2 | V168181X012 | V131681X022 | V131681X042 | V131681X052 |
| 14 | | 2 | 13B2777X012 | V127739X032 | V127739X042 | --- |
| 16 | | 2 | 13B2778X012 | V137374X032 | V137374X012 | --- |
| 18 | | 2 | 13B2779X012 | V112445X022 | V112445X012 | --- |
| 20 | | 2 | 13B2780X012 | V112016X012 | V112016X022 | --- |
| 24 | | 2 | 13B2781X012 | V157177X022 | V157177X012 | --- |
| 30 | 150/150 | 2 | 13B1584X012 | V171360X012 | V171360X022 | V171360X042 |
| | 150 | 2 | V167656X012 | V171364X012 | V171364X022 | V171364X042 |
| | 300 | 2 | 13B1959X012 | V175127X012 | V175127X022 | V175127X042 |
| 36 | 150/150 | 2 | 13B1960X012 | V136767X022 | V136767X032 | V136767X042 |
| | 150 | 2 | 13B1961X012 | V171362X012 | V171362X022 | V171362X052 |
| | 300 | 2 | 13B1962X012 | V116148X012 | V116148X022 | V116148X052 |
| 42 | 150/150 | 2 | 13B1963X012 | V125303X012 | V125303X022 | V125303X052 |
| | 150 | 2 | 13B1964X012 | V137636X012 | V137636X042 | V137636X052 |
| | 300 | 2 | 13B1965X012 | V130097X012 | V130097X032 | V130097X042 |
| 48 | 150/150 | 2 | 13B1769X012 | V113699X012 | V113699X042 | V113699X032 |
| | 150 | 2 | 13B1966X012 | V151148X012 | V151148X042 | V151148X052 |
| | 300 | 2 | 13B1967X012 | V117029X012 | V117029X032 | V117029X042 |

Instruction Manual

Form 5338
February 2007

A11 Valve

Key 14* Packing Set

| VALVE SIZE, INCHES | CLASS | MATERIAL | | |
|--------------------|---------|-------------|-------------|------------------------------|
| | | PTFE V-Ring | Graphite | Graphite with Oxygen Service |
| 3 | 600 | V113124X022 | V113124X012 | V113124X032 |
| 4 | | V113128X022 | V113128X012 | V113128X032 |
| 6 | | V111025X022 | V111620X012 | V111025X032 |
| 8 | | V110456X012 | V110456X022 | V110456X032 |
| 10 | | V111028X032 | V111028X012 | V111028X022 |
| 12 | | V111696X032 | V111696X012 | V111696X022 |
| 14 | | V111442X032 | V111442X012 | V111442X022 |
| 16 | | V111705X032 | V111705X012 | V111705X022 |
| 18 | | V111709X032 | V111709X012 | V111709X022 |
| 20 | | V125909X022 | V125909X012 | --- |
| 24 | | V112041X012 | V112041X022 | --- |
| 30 | | 150/150 | V111699X012 | V111442X012 |
| 30 | 150 | V111704X012 | V111705X012 | V111705X022 |
| 30 | 300 | V121593X012 | V115138X012 | V115138X022 |
| 36 | 150/150 | V117210X012 | V116838X012 | V116838X022 |
| 36 | 150 | V121811X012 | V129596X012 | V129596X022 |
| 36 | 300 | V122149X012 | V115155X012 | V115155X022 |
| 42 | 150/150 | V114721X012 | V126139X012 | V126139X022 |
| 42 | 150 | V112038X012 | V112039X012 | V112039X022 |
| 42 | 300 | V130100X012 | V147154X012 | V147154X022 |
| 48 | 150/150 | V119322X012 | V115058X012 | V115058X022 |
| 48 | 150 | V126979X012 | V119524X012 | V119524X022 |
| 48 | 300 | V130450X012 | V147480X012 | V147480X022 |

A11 Valve

Key 19* Retainer Gasket (not shown)

| VALVE SIZE, INCHES | CLASS | MATERIAL | | |
|--------------------|---------------|-------------------------------|--|--|
| | | Standard Service Soft Seal | Standard Service Metal/Phoenix III Seal | Oxygen Service with Soft or Metal Seals |
| 8 | 600 | V135212X022 | V135212X012 | V135212X032 |
| 10 | | V135209X022 | V135209X012 | V135209X032 |
| 12 | | V148910X032 | V148910X012 | V148910X022 |
| 14 | | V139619X022 | V139619X012 | V139619X032 |
| 16 | | V112057X012 | V112057X022 | V112057X032 |
| 18 & 20 | | V112058X012 | V112058X022 | --- |
| 24 | | V144925X012 | V144925X022 | --- |
| 30 | | 150/150 | V124603X022 | V124603X012 |
| 30 | 150 | V135139X022 | V135139X012 | V135139X032 |
| 30 | 300 | V148908X022 | V148908X012 | V148908X032 |
| 36 | 150/150 | V135139X022 | V135139X012 | V135139X032 |
| 36 | 150 | V135138X022 | V135138X012 | V135138X032 |
| 36 | 300 | V148909X022 | V148909X012 | V148909X032 |
| 42 | 150 & 150/150 | V135211X022 | V135211X012 | V135211X032 |
| 42 | 300 | V147155X022 | V147155X012 | V147155X032 |
| 48 | 150/150 | V135138X022 | V135138X012 | V135138X032 |
| 48 | 150 | V148908X022 | V148908X012 | V148908X032 |
| 48 | 300 | V171283X022 | V171283X012 | V171283X032 |

Instruction Manual

Form 5338
February 2007

A11 Valve

Key 28*, Disc-Shaft-Pin Assembly⁽¹⁾ Square Connection [Disc (key 3), Shaft (key 4), Follower Shaft (key 5), and Pin (key 6)]

| VALVE SIZE, INCHES | SHAFT MATERIAL ⁽²⁾ | DISC MATERIAL | | |
|--------------------|-------------------------------|--------------------|-------------|----------------|
| | | CF8M Chrome Coated | CF8M ENC | CF8M Hard Face |
| 3 | S17400 H1025 | V138800X092 | V138800X022 | V138800X032 |
| | N05500 | V138800X112 | V138800X052 | V138800X142 |
| | S17400 H1150M | V138800X102 | V138800X012 | V138800X152 |
| 4 | S17400 H1025 | V161632X082 | V161632X042 | V161632X022 |
| | N05500 | V161632X102 | V161632X012 | V161632X122 |
| | S17400 H1150M | V161632X092 | V161632X152 | V161632X142 |
| 6 | S17400 H1025 | V161647X092 | V161647X052 | V161647X042 |
| | N05500 | V161647X122 | V161647X132 | V161647X022 |
| | S17400 H1150M | V161647X102 | V161647X012 | V161647X152 |
| 8 | S17400 H1025 | V145082X102 | V145082X012 | V145082X062 |
| | N05500 | V145082X122 | V145082X052 | V145082X142 |
| | S17400 H1150M | V145082X112 | V145082X032 | V145082X152 |
| 10 | S17400 H1025 | V126325X082 | V126325X012 | V126325X032 |
| | N05500 | V126325X102 | V126325X052 | V126325X152 |
| | S17400 H1150M | V126325X092 | V126325X042 | V126325X062 |
| 12 | S17400 H1025 | V126329X042 | V126329X012 | V126329X032 |
| | N05500 | V126329X062 | V126329X112 | V126329X122 |
| | S17400 H1150M | V126329X052 | V126329X132 | V126329X142 |

1. Part numbers provided in this table are assembly numbers including keys 3, 4, 5 and 6. The pin (key 6) is listed as a spare part and can be ordered without the assembly.
2. The same shaft material is used in one or two shaft valve assemblies.

Key 28*, Disc-Shaft-Pin Assembly⁽¹⁾ Keyed Connection [Disc (key 3), Shaft (key 4), Follower Shaft (key 5), and Pin (key 6)]

| VALVE SIZE, INCHES | SHAFT MATERIAL ⁽²⁾ | DISC MATERIAL | | |
|--------------------|-------------------------------|---------------|-------------|--------------------|
| | | CF8M | CF8M ENC | CF8M Chrome Coated |
| 30 Class 150 | S17400 H1025 | 13B3474X022 | 13B3474X102 | 13B3474X062 |
| | N05500 | 13B3474X212 | 13B3474X222 | 13B3474X172 |
| | S17400 H1150M | 13B3474X152 | 13B3474X162 | 13B3474X052 |
| 36 Class 150 | S17400 H1025 | 13B3529X042 | 13B3529X062 | 13B3529X022 |
| | N05500 | 13B3529X172 | 13B3529X182 | 13B3529X192 |
| | S17400 H1150M | 13B3529X102 | 13B3529X122 | 13B3529X132 |

1. Part numbers provided are assembly numbers including keys 3, 4, 5 and 6. The pin (key 6) is listed as a spare part and can be ordered without the assembly.
2. The same shaft material is used in one or two shaft valve assemblies.

ENVIRO-SEAL and Fisher are marks owned by Fisher Controls International LLC, a member of the Emerson Process Management business division of Emerson Electric Co. Emerson and the Emerson logo are trademarks and service marks of Emerson Electric Co. All other marks are the property of their respective owners.

The contents of this publication are presented for informational purposes only, and while every effort has been made to ensure their accuracy, they are not to be construed as warranties or guarantees, express or implied, regarding the products or services described herein or their use or applicability. We reserve the right to modify or improve the designs or specifications of such products at any time without notice.

Neither Emerson, Emerson Process Management, nor any of their affiliated entities assumes responsibility for the selection, use and maintenance of any product. Responsibility for the selection, use and maintenance of any product remains with the purchaser and end-user.

Emerson Process Management

Marshalltown, Iowa 50158 USA

Cernay 68700 France

Sao Paulo 05424 Brazil

Singapore 128461

www.Fisher.com

