

ELECTRIC PILOT HEATER

SUMMARY

APPLICATION	1
CHARACTERISTICS	2
LABELLING	2
DIMENSIONS AND WEIGHTS	2
SPARE PARTS	3
INSTALLATION	3
DECLARATION OF CONFORMITY	4



Type RPE

APPLICATION

Used for reheating gas supplying pressure reducing regulator pilots the RPE avoids the inconveniences caused by freezing which occur during large pressure drops.

There also exists a « regulator bottom » version (particularly for relief lines).

The RPE is in conformity with the Directive for Equipment or protective system intended for use in potentially explosive atmospheres 94/9/CE.
It is classified under group II, category 2.

CHARACTERISTICS

Maximum operating pressure (thermometer pocket + heating element)	100 bar
Electrical material for explosive atmospheres	
• Group according to directive 94/9/CE	Group II
• Category according to directive 94/9/CE	Category 2
• Protection	EEx d IIC T2
• Classification	ISSeP 03 ATEX 090
• Power supply	230 V 50-60 Mz
• Power consumption	140 W
• Recommended operating temperature	0 to 30 °C
• Max. allowable admitted temperature	60 °C
Recommended thermostat settings	
• Selector for temperature A range	0/30
• Adjustment for B setting	30
• Differential selector C	2

Temperature measurement		
• Interchangeable thermic probe		10 kΩ
Heater		
• 2 interchangeable heating cartridges (use grease ref. 720001 for installation)		280 W - 230 V
• Connected in series		140 W
Temperature regulation range		
• Thermostat		- 30 to + 90 °C
Power supply		
• Power relay	I max U	2 A 250 V~
Protection		
• Thermostat		2 A
• Power relay		2 A

LABELLING

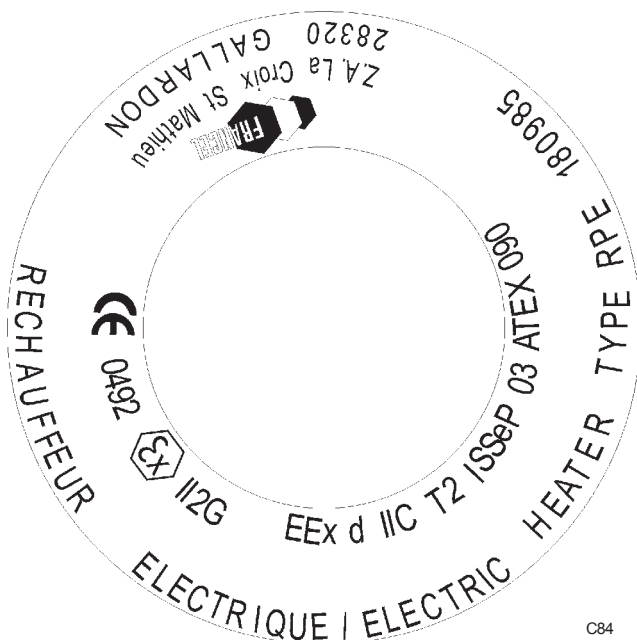

DIMENSIONS AND WEIGHTS

Heater only : 1.4 kg
 Heater + heating element : 4.5 kg

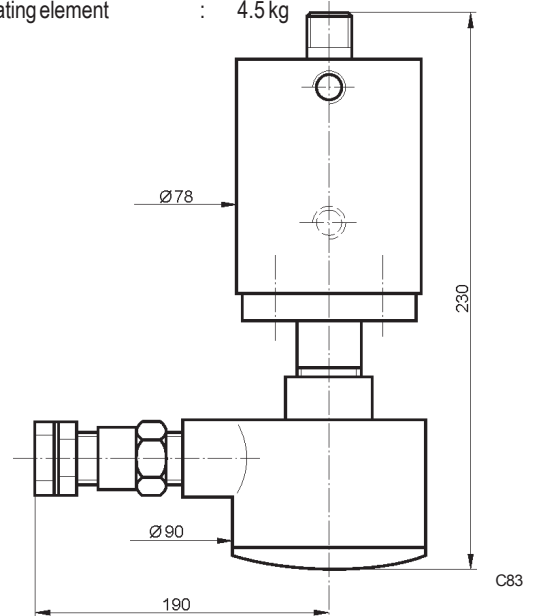

WARNING

- No modification should be made to the structure of the equipment (drilling, grinding, soldering...).
- The equipment should not receive any type of shock.
- All interventions on the equipment should only be performed by qualified and trained personnel.

WARNING

- Verify the integrity of the equipment before commissioning.
- Respect the installation and connection instructions.
- Do not open when switched on.
- Do not switch on when box is open.

SPARE PARTS

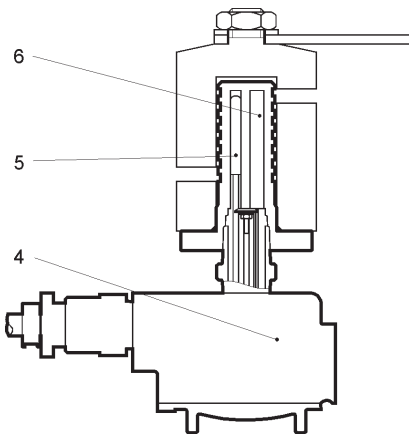

C80a

1 - Heater with heating element

INSTALLATION

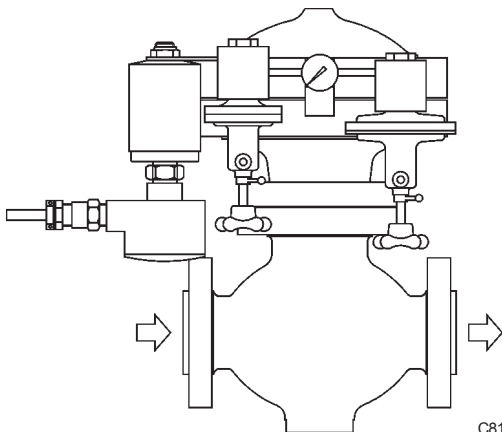

C81

ASSEMBLY

Electrical pilot heater (with heating element)

The RPE is assembled with the vertical thermometer pocket axe using the fixing part supplied with the regulator actuator bolt.

Regulator bottom electrical heater

The RPE is assembled on the regulator bottom with 4 fixing screws M8 x 20. The RPE can be installed in an explosive risk zone.

The thermostat and power relay must be installed in a non-explosive risk zone.

PNEUMATIC CONNECTIONS

The RPE is to be installed between the pilot filter and the pre-expansion relay. Inlet/Outlet: 1/4 NPT - tube 8/10 (regardless of the gas flow).

Item	Description	Reference
1-2-3	ATEX heater with heating element, Thermostat and Relay	197 519
2	Thermostat	461 328
3	Relay	461 330

1	ATEX heater with heating element	197 520
4	ATEX heater without heating element	180 985B
5	Probe	461 363
6	Heating cartridge*	461 365

* Two by heater

C85

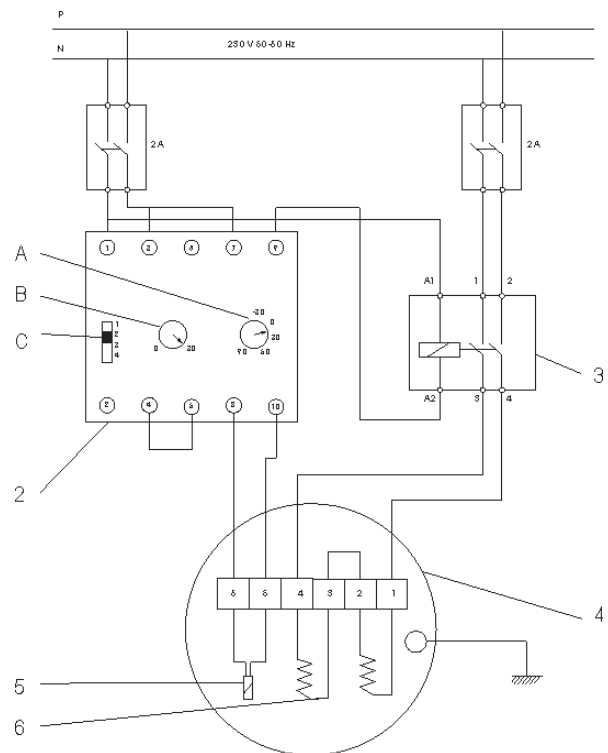

C82

Assembly on symmetrical DIN Rail

ELECTRICAL CONNECTIONS

Electrical RPE box: Packing gland 3/4" NPT for cable snap-on

Electrical wiring: Customer (according to schema C82)

Recommended wiring: U-1000 RVFV, according to NF C32-322, type class 2.5, conductors 1.5 mm²

Nota : the electrical terminals 4 and 6 of the thermostat (2) must be shunted to cut off supply in the case of rupture of the thermal probe (5).

Nota : the electrical terminals 2 and 3 of the RPE connector block (4) must be shunted so that the heating elements (6) are connected in series.

Nota : the thermostat (2) and the power relay (3) must be protected by 2A fuses (protection against short-circuit of the heating elements).

Nota : the thermostat (2) and the power relay (3) are assembled on a symmetrical DIN rail.



(1) **EC TYPE EXAMINATION CERTIFICATE**

(2) **Equipment or protective system intended for use in potentially explosive atmospheres Directive 94/9/EC**

(3) EC type examination certificate number: **ISSeP03ATEX090**

(4) Equipment or protective system:
Electric Heater type RPE 180 985.

(5) Applicant – Manufacturer – Authorized representative in the Community:
FRANCEL S.A.

(6) Address:
Z.A. La Croix Saint Mathieu
28320 Gallardon
France

(7) This equipment or protective system and any acceptable variation thereto is specified in the schedule to this certificate and the documents therein referred to.

(8) ISSEP, notified body n° 492 in accordance with article 9 of the Council Directive 94/9/EC of 23 March 1994, certifies that this equipment or protective system has been found to comply with the Essential Health and Safety Requirements relating to the design and construction of equipment and protective systems intended for use in potentially explosive atmospheres given in annex II to the Directive.

The examination and test results are recorded in confidential report n° 03131.

(9) Compliance with the Essential Health and Safety Requirements has been assured by compliance with:
EN 50014 : 1997 + amendments 1 and 2 ; 1999
EN 50018 : 2000

(10) If the symbol "X" is placed after the certificate number, it indicates that the equipment or protective system is subject to special conditions for safe use specified in the schedule to this certificate.

(11) This EC TYPE EXAMINATION CERTIFICATE relates only to the design, examination and tests of the specified equipment or protective system in accordance to the Directive 94/9/EC. Further requirements of this Directive may apply to the manufacturing process and supply of this equipment or protective system. These are not covered by this certificate.

(12) The marking of the equipment or protective system shall include the following indications:
II 2 G / EEx d IIC T2

Colfontaine, 29.07.2003.
Renaud Alain
Renaud Alain
Manager of Colfontaine division

INSTITUT SCIENTIFIQUE DE SERVICE PUBLIC
Zoning A. Schweitzer, rue de la Platerie
B-7340 COLFONTAINE (Waremme)
Tél: ++ 32 65 610811 – Fax: ++ 32 65 610808

This certificate may only be reproduced in its entirety and without any change, schedule included

(13) **SCHEDULE**

(14) **EC TYPE EXAMINATION CERTIFICATE N° ISSeP03ATEX090**

(15) **Description of the equipment or protective system :**

- Electric Heater type RPE 180 985.
- The Heater consists of :
 - A flameproof enclosure.
 - A link device.
 - A thermowell fitted with two heating cartridges (230 V - 208 W) connected in series, 230 V powered.
 - A sensor for the temperature regulation.
- The Heater is fitted with a flameproof cable gland.

Marking :

- Name and address of the the manufacturer.
- Manufacturer's type identification.
- Serial number.
- Year of manufacture.
- Specific marking of explosion protection : II 2 G
- Code : EEx d IIC T2
- Indication of testing station followed by the reference of the certificate.
- Complementary marking : "DO NOT OPEN WHEN ENERGIZED"
- Any other marking required by the standards of construction of the electrical apparatus.

Routine verifications and tests : (Clause 24 of EN 50014)

The manufacturer shall make the routine verifications and tests necessary to ensure that the electrical apparatus produced complies with the specification submitted to the testing station together with the prototype or sample.
The routine pressure test exemption is conceded (clause 16 of EN 50018).

Eventual prescriptions : according to the technical notice NTRPE03.

(16) **Report n° 03131 of 22.07.2003 (18 pages) completed by the descriptive documents below :**

- Technical documentation DT RPE of 23.05.2003 (3 pages).
- Technical notice NTRPE03 (4 pages).
- Extract of catalog related to the cable entry Capri type ADL (2 pages).
- Drawings :

Number	Revision	Date	Description
180985	B	22.05.2003	Réchauffeur électrique
985	A	11.07.1996	Dimensionnements
142388	B	22.05.2003	Plaque d'identification
142364	A	11.07.1996	Doigt de gant
142365	A	11.07.1996	Mamelon

Certificate	Description
CESI01ATEX105	Terminal Boxes
CESI03ATEX062	Terminal Boxes

(17) **Special conditions for safe use :** None

(18) **Essential Health and Safety Requirements :**

The Essential Health and Safety Requirements are covered by :

- The conformity to European Standards EN 50014 and EN 50018.
- All safety measures taken by the manufacturer and described in the descriptive documentation listed at (16).

DECLARATION OF CONFORMITY FRANCEL

We declare that the electrical heaters, type RPE, are aimed to put on the market for usage in explosive atmospheres and that they apply to the following:

- articles of the directive 94/9/CE
- norms :
 - EN 50 014 (March 1999)
 - EN 50 018 (April 1996)

This equipment has been tested and examined to obtain a certificate type CE

Certificate number : **ISSeP 03 ATEX 090**

Notified Organisation: ISSEP (identification number 0492)

**Emerson Process Management
Regulator Division
Francel S.A.**
Z.A. La Croix St. Mathieu
28320 Gallardon - France
Tel. +33 (0)2 37 33 47 00
Fax. +33 (0)2 37 31 46 56
www.francel.com

© Francel S.A. 2004, printed in France by MARCOM Francel
Characteristics, dimensions and diagrams only commit FRANCEL after written confirmation

