

# Commercial Service Regulator Platform



Engineered to fit a multitude of applications.



# Next Generation of Pressure Regulator Technology



## The Commercial Service Regulator Family of Products from the Technology Leader in Pressure Regulation

Every global customer has a unique gas system based on inlet pressures, delivery pressures, accuracy, flow and overpressure protection requirements. To meet these needs, customers currently utilize several regulator designs and overpressure protection methods from one or more suppliers. This results in nonstandard installations or meter sets, various maintenance requirements and methods, training issues and stocking of a multitude of spare parts.

To meet the current and future needs of worldwide customers, Emerson Process Management has designed the Commercial Service Regulator platform. This platform brings a patentable, modular design that has never been seen in previous regulators, resulting in:

- Easy product sizing and selection
- Broad platform, wide application coverage
- Reduced inventory through shared parts
- Reduced training and maintenance through streamlined design

### The Ultimate in Selectivity

With three new actuator designs and modular components, the Commercial Service Regulator family's streamlined platform offers advanced capabilities for natural gas, industrial process and LP-gas applications. A carefully engineered fit makes it easy to select the exact pressure regulator and overpressure protection required.

### Product Advantages:

- **Lower cost of ownership/ reduced time and expense for**
  - training
  - installation
  - maintenance
- **Highly configurable**
  - All actuators and slam-shut are fully rotational for installation in any orientation
  - External, internal or dual-registration for flexible skid and field installation
  - Multiple overpressure protection options
  - Balanced or unbalanced trim
- **Multiple body sizes and configurations to fit new and replacement applications**



# The Highest Quality Engineering and Performance Tailored to Fit Your Application

## Our Unique Commercial Service Regulator Platform

### Trim Style

- Balanced
- Unbalanced

### Amplification

- Direct-Operated
- Pressure-Loaded

### Internal Relief

- Token
- Standard
- High-Capacity

### Pressure Registration

- Internal
- External
- Dual

### Overpressure Protection

- True-Monitor™ Protection
- Slam-Shut Protection
- High-Capacity Relief
- Secondary Seat™ Protection



**The distinctive swirl pattern** cast into every Commercial Service Regulator actuator casing, uniquely identifies the regulator as a genuine Fisher® Commercial Service Regulator Platform product, and assures you of the highest quality engineering, performance and support traditionally associated with Fisher®, Francel™ and Tartarini™ regulators.



## Proven Performance

To ensure the same standard of excellence as the current Fisher®, Francel™ and Tartarini™ products, Emerson utilized state-of-the-art computerized design and engineering tools. These tools included computational flow dynamics (CFD), finite element analysis (FEA) and 3-D parts modeling. All designs were extensively tested in Emerson's world-class flow testing laboratory.

Products are designed and tested in accordance with the following industry standards:

- EN 334 and EN 14382
- Pressure Equipment Directive (CE)
- ANSI B16.1
- ASME Section 8
- ANSI B109.4
- CSA B149/CSA 6.18
- Measurement Canada (PFM/Fixed Factor)

## Complete Overpressure Protection

There is always a need for overpressure protection in gas distribution systems. To meet unique customer requirements, Emerson has designed the following options in overpressure protection:

- Next generation in True-Monitor™ Protection
- Enhanced slam-shut capability
- Improved internal relief
- The evolution of Secondary Seat™ Protection

These technological advancements provide complete overpressure protection.

### True-Monitor™ Protection

Combines the operation of a conventional two-regulator wide-open monitor set into one body.

### Slam-Shut Protection

Discontinues gas service by shutting the gas off when there is an overpressure or underpressure condition.

### Secondary Seat™ Protection

Provides overpressure protection in case of a failure of the primary orifice and seat.

### High-Capacity Internal Relief

Full capacity internal relief minimizes the need for secondary overpressure protection devices.



True-Monitor™ Protection

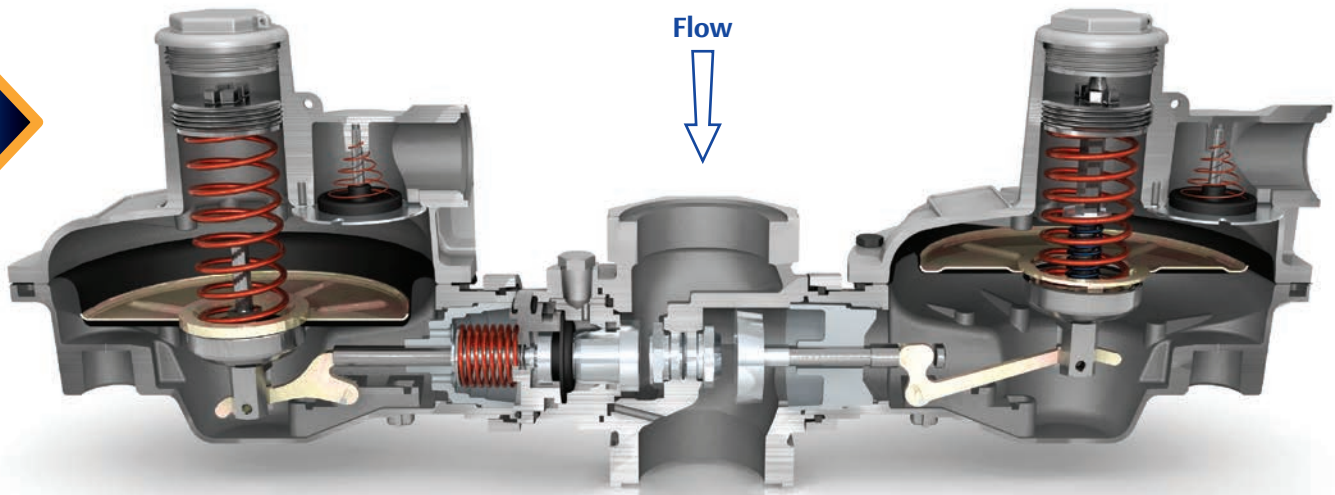

Slam-Shut Protection

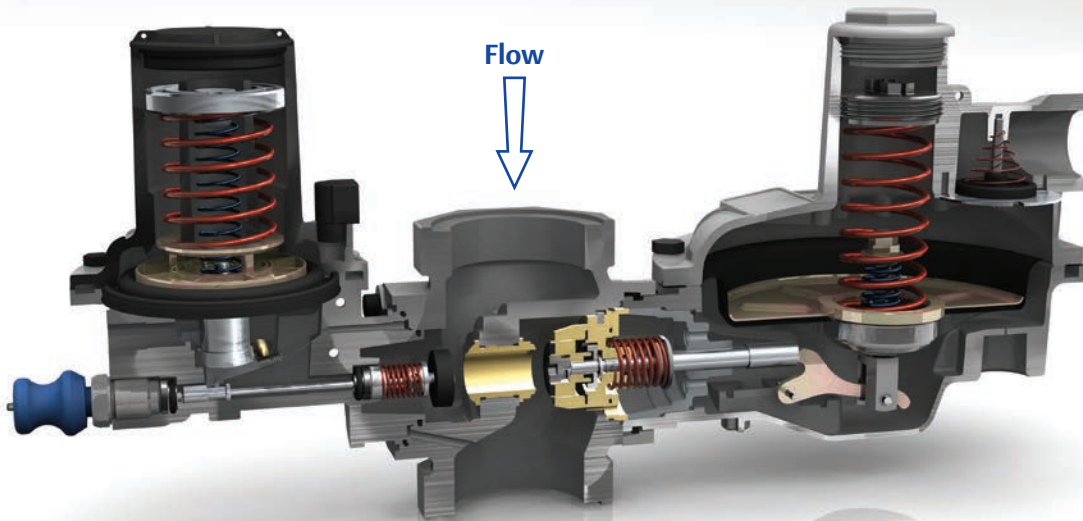

Secondary Seat™ Protection

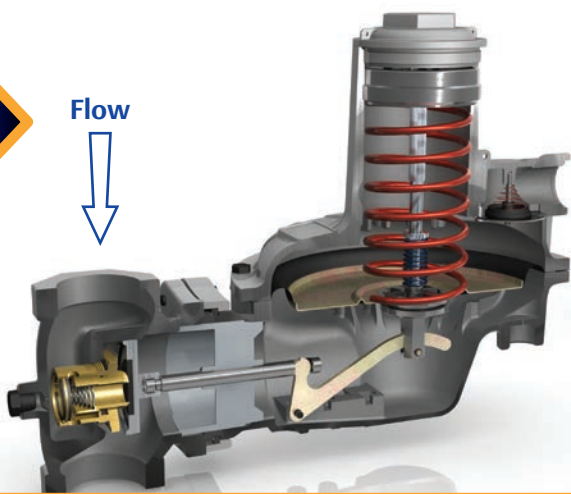

High-Capacity Internal Relief

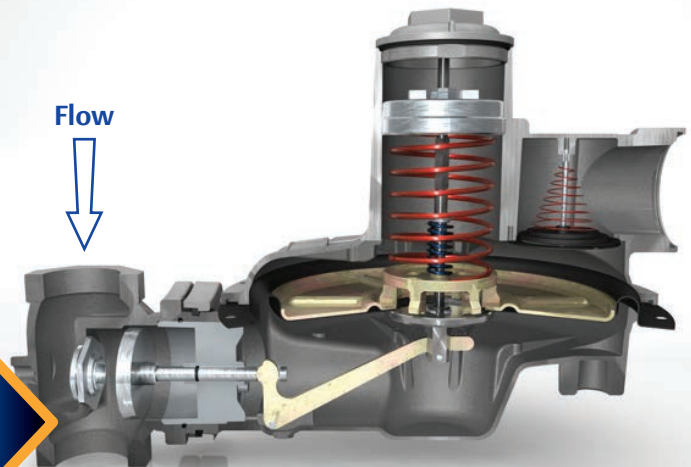

# Selection Chart

Series	Operation	Maximum Operating Inlet Pressure PSIG / bar	Outlet Pressure Ranges	Body Sizes	OVERPRESSURE PROTECTION					
					Maximum Orifice/Port Size inches / mm	True-Monitor™ Protection	Slam-Shut	High-Capacity Relief	Internal Relief	Secondary Seat™ Protection
<b>CS200</b>	Direct-Operated	125 / 8,6	3.5-inches w.c. to 2 psig / 9 mbar to 138 mbar	3/4, 1, 1-1/4 NPT	1/2 / 13				X	X
<b>CS400</b>	Direct-Operated	125 / 8,6	3.5-inches w.c. to 5.5 psig / 9 mbar to 380 mbar	1-1/4, 1-1/2, 2 NPT/RP NPS 2 / DN50 Flange	3/4 / 19	X	X		X	
<b>CS800</b>	Direct-Operated	125 / 8,6	3.5-inches w.c. to 10 psig / 9 mbar to 690 mbar	1-1/4, 1-1/2, 2 NPT/RP NPS 2 / DN50 Flange	1-3/8 / 35	X	X	X	X	X
<b>CSB400</b>	Direct-Operated	232 / 16	6.8 inches w.c. to 43.5 psig / 17 mbar to 3 bar	1, 1-1/4, 1-1/2, 2 NPT/RP NPS 2 / DN50 Flange	11/16 / 125	X	X		X	
<b>CSB600</b>	Direct-Operated	232 / 16	3.5-inches w.c. to 58 psig / 9 mbar to 4 bar	1-1/4, 1-1/2, 2 NPT/RP NPS 2 / DN50 Flange	1 / 25		X		X	
<b>CSB700</b>	Direct-Operated	232 / 16	3.5-inches w.c. to 58 psig / 9 mbar to 4 bar	1-1/4, 1-1/2, 2 NPT/RP NPS 2 / DN50 Flange	1-3/8 / 35		X		X	
<b>CP200</b>	Pressure-Loaded	125 / 8,6	1psig to 20 psig / 69 mbar to 1,4 bar	3/4, 1, 1-1/4 NPT	1/2 / 13				X	X
<b>CP400</b>	Pressure-Loaded	125 / 8,6	1psig to 20 psig / 69 mbar to 1,4 bar	1-1/4, 1-1/2, 2 NPT/RP NPS 2 / DN50 Flange	3/4 / 19	X	X		X	

## Emerson Process Management Regulator Technologies, Inc.

### Americas

#### Worldwide Headquarters

3200 Emerson Way  
McKinney, Texas 75070 USA  
T: +1 800 558 5853  
T: +1 972 548 3574  
F: +1 972 542 6433

#### TESCOM Corporation

12616 Industrial Boulevard  
Elk River, Minnesota 55330-2445 USA  
T: +1 800 447 1250  
T: +1 763 241 3238  
F: +1 763 241 3224

For further information visit [www.emersonprocess.com/regulators](http://www.emersonprocess.com/regulators)

D351223X012 © 2014 Emerson Process Management Regulator Technologies, Inc. All rights reserved. Printed in the U.S.A. 11/14. Fisher, Tartarini, Francel, Emerson Process Management and the Emerson Process Management design are marks of one of the Emerson Process Management group of companies. All other marks are the property of their respective owners.

## Our Global Product Brands:



## Emerson Process Management Regulator Technologies, Inc.

### Asia Pacific

T: +65 6770 8337

### Middle East

T: +971 4811 8100

