

Y695VR Series Vacuum Regulator

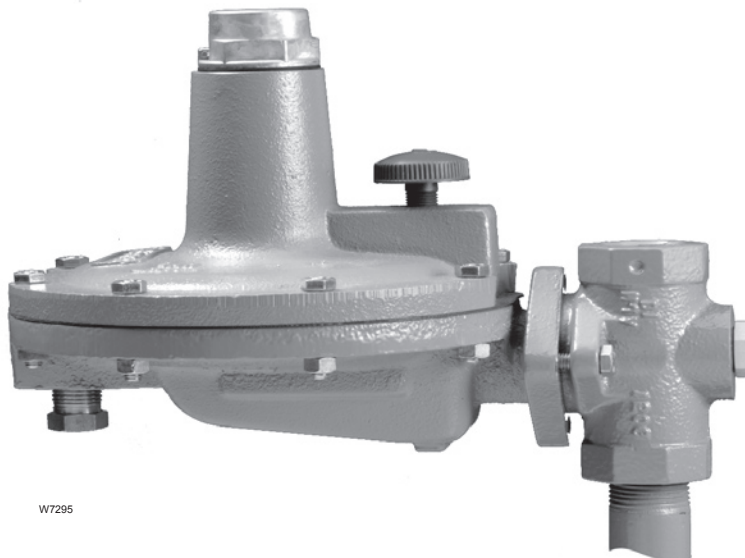

Figure 1. Type Y695VR Vacuum Regulator

Introduction

The Y695VR Series direct-operated vacuum regulators are used where a decrease in vacuum must be limited, such as between a tank and vacuum source to control vacuum in tank. The Type Y695VR has internal pressure registration. The Type Y695VRM has a control line connection and blocked throat for external pressure registration.

Features

- **Tamper Resistant Adjustment**—Closing cap and spring case on many types allow installation of sealing wire to discourage or detect unauthorized adjustment of pressure setting.
- **Precision Control of Low Pressure Settings**—Large diaphragm areas provide more accurate control at low pressure settings.
- **Easy Conversion**—The Y695VR Series Vacuum Regulators are easily adapted between external and internal registration.
- **Common Spare Parts**—The Type Y695VR and Type Y695VRM share common spare parts with the other Y690A Series products.
- **Corrosion Resistance**—Constructions are available in a variety of materials for compatibility with corrosive process gases.



Bulletin 71.3:Y695VR

Specifications

Available Configurations

Type Y695VR: Direct-operated vacuum regulator
Type Y695VRM: Direct-operated vacuum regulator with blocked throat for external pressure registration

Body Sizes and End Connection Styles⁽¹⁾

| BODY SIZE, INCHES (DN) | END CONNECTION STYLES | |
|------------------------|-----------------------|--------------------------|
| | Ductile Iron | Steel or Stainless Steel |
| 3/4 or 1 (20 or 25) | NPT | NPT, SWE, or CL150 RF |

1. Weld-on flange dimension is 14-inches (356 mm) face-to-face.

Maximum (Casing) Pressure⁽²⁾

Full Vacuum

Maximum Downstream Pressure⁽²⁾

Full Vacuum

Change in Control Pressure to Wide-open⁽²⁾

See Table 2

Pressure Registration

Type Y695VR: Internal
Type Y695VRM: External

Orifice Size

7/16-inch (11 mm)

Capacities

See Table 2

Flow Coefficients

C_g : 120
 C_v : 3.43
 C_1 : 35

Material Temperature Capabilities⁽²⁾

Nitrile (NBR): -20° to 180°F (-29° to 82°C)
Fluorocarbon (FKM): 40° to 300°F (4° to 149°C)
Perfluoroelastomer (FFKM): -20° to 300°F (-29° to 149°C)

Spring Case Connection

1/4-inch NPT

Diaphragm Case Connection

1/2-inch NPT

Construction Materials

See Table 1

Pressure Setting Adjustment

Adjusting nut

Additional Options

Umbrella vent assembly for spring case connection

Approximate Weight

19 pounds (9 kg)

1. End connections for other than U.S. standards can usually be provided; consult the local Sales Office.

2. The pressure/temperature limits in this bulletin and any applicable standard or code limitation should not be exceeded.

Table 1. Construction Materials

| BODY | SPRING CASE | DIAPHRAGM CASE | TRIM | DIAPHRAGM | DISK |
|---|--------------------------------------|--------------------------------------|---------------------|-------------------------------------|-------------------------------------|
| Ductile iron, CF8M Stainless steel, or Hastelloy® C | Ductile iron or CF8M Stainless steel | Ductile iron or CF8M Stainless steel | 316 Stainless steel | Nitrile (NBR) or Fluorocarbon (FKM) | Nitrile (NBR) or Fluorocarbon (FKM) |

Table 2. Y695VR Series Capacities

| SPRING RANGE, PART NUMBER, AND COLOR | SPRING WIRE DIAMETER | MAXIMUM ALLOWABLE VACUUM | CONTROL PRESSURE SETTING VACUUM | OUTLET VACUUM | CHANGE IN CONTROL PRESSURE TO WIDE-OPEN | CAPACITY IN SCFH (Nm³/h) OF 1.0 SPECIFIC GRAVITY AIR |
|---|------------------------|--------------------------|---------------------------------|---------------------|---|--|
| 0 to 4-inches w.c. (0 to 10 mbar) ON039427222 Unpainted | 0.062-inches (1,57 mm) | 5.1 psig (0,35 bar) | 2-inches w.c. (5 mbar) | 7.5 psig (0,52 bar) | 1-inch w.c. (2 mbar) | 1650 (44,2) |
| 0.05 to 0.75 psig (0,003 to 0,05 bar) ON086027022 Unpainted | 0.105-inches (2,67 mm) | 5.7 psig (0,39 bar) | 0.5 psig (0,03 bar) | 7.5 psig (0,52 bar) | 5.5-inches w.c. (14 mbar) | 1614 (43,3) |
| 0.15 to 1.75 psig (0,01 to 0,12 bar) ON086127022 Unpainted | 0.125-inches (3,18 mm) | 6.5 psig (0,45 bar) | 1 psig (0,07 bar) | 7.5 psig (0,52 bar) | 0.44 psig (0,03 bar) | 1578 (42,3) |
| 0.25 to 2.75 psig (0,02 to 0,19 bar) ON022027022 Dark green | 0.135-inches (3,43 mm) | 7.4 psig (0,51 bar) | 2 psig (0,14 bar) | 7.5 psig (0,52 bar) | 0.63 psig (0,04 bar) | 1464 (39,2) |
| 1.5 to 4.75 psig (0,10 to 0,33 bar) ON004327022 Yellow | 0.172-inches (4,37 mm) | 9.2 psig (0,63 bar) | 4 psig (0,28 bar) | 7.5 psig (0,52 bar) | 1.44 psig (0,10 bar) | 1290 (34,6) |
| 3.0 to 12.8 psig (0,21 to 0,88 bar) 1D141827012 Dark blue | 0.207-inches (5,26 mm) | 12.0 psig (0,83 bar) | 9 psig (0,62 bar) | 12 psig (0,83 bar) | 3.88 psig (0,27 bar) | 1140 (30,6) |

Principle of Operation

The Y695VR Series vacuum regulators are used to maintain a constant vacuum at the regulator inlet. A decrease in this vacuum (increase in absolute pressure) beyond this value registers on the diaphragm and opens the disk. This permits a downstream vacuum of lower absolute pressure than the upstream vacuum to restore the upstream vacuum to its original pressure setting. On the Type Y695VR, pressure registers underneath the diaphragm. The Type Y695VRM has a control line connecting the diaphragm casing to the vacuum line and an O-ring stem seal blocking the throat causing pressure to register through the control line.

Capacity Information

To determine the flow capacities for the Y695VR Series vacuum regulators, use the following formula:

$$Q = P_{1abs} C_g \text{SIN} \left[\frac{3415}{C_1} \sqrt{\frac{\Delta P}{P_{1abs}}} \right] \text{Deg.}$$

where,

- Q = flow capacity in SCFH (60°F and 14.7 psia) of air at 60°F
- P_{1abs} = absolute inlet pressure in psia (P₁ gauge + 14.7)
- C_g = flow coefficient (from specifications table)
- C₁ = 35
- ΔP = pressure drop across vacuum breaker or regulator

Note

If the actual change in (control) pressure (from the service conditions) is less than the minimum change in (control) pressure required to fully open the vacuum regulator (Table 2), the C_g in the formula must be reduced accordingly. To obtain the correct reduced C_g, multiply the C_g from specifications table by the ratio of the actual change in (control) pressure to the minimum change in (control) pressure required to fully open the vacuum regulator.

Conversion Factors

To determine equivalent capacities of natural gas, propane, butane, or nitrogen, multiply the calculated capacity by the following appropriate conversion factor: 1.29 for natural gas, 0.810 for propane, 0.707 for butane, or 1.018 for nitrogen. For gases of

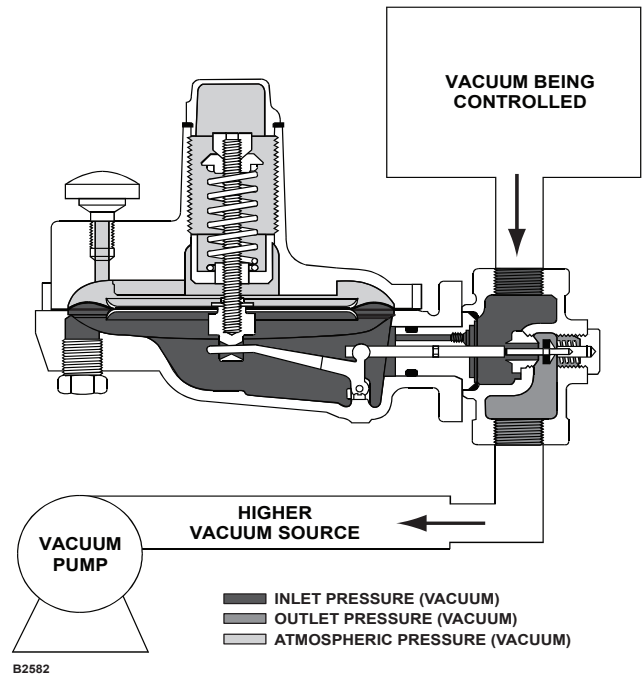

Figure 2. Type Y695VR Operational Schematic

other specific gravities, divide by the square root of the appropriate specific gravity. Then, if capacity is desired in normal cubic meters per hour at 0°C and 1.01325 down to allow condensate to drain. On indoor installations, this connection should be piped outdoors if used in hazardous gas service. External dimensions and connections are shown in Figure 3.

Note

Downstream piping will vary with the installation, but to obtain the calculated characteristics, the pipe should be the same size as the outlet and should be straight for the first 18-inches (457 mm).

Ordering Information

When ordering, specify:

Application

1. Composition and specific gravity of gas (including chemical analysis if possible)
2. Range of temperatures, flowing inlet pressures (maximum, minimum, nominal), and pressure drops
3. Desired pressure setting or range
4. Range of flow rates (minimum controlled, maximum, normal)
5. Piping size(s)

Bulletin 71.3:Y695VR

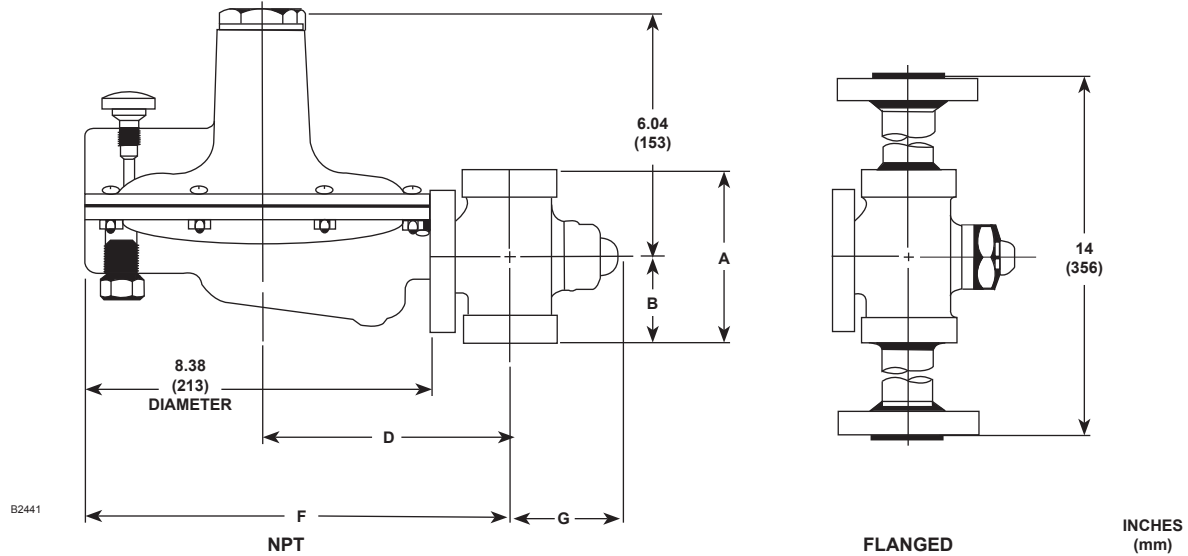

| BODY SIZE, INCHES (DN) | DIMENSIONS, INCHES (mm) | | | | | | | | | |
|---------------------------|-------------------------|------------------------|-----------------|--------------------|-----------------|--------------------|-----------------|--------------------|-----------------|--------------------|
| | A | | B | | D | | F | | G | |
| | Ductile Iron NPT | Stainless Steel NPT | Ductile Iron | Stainless Steel | Ductile Iron | Stainless Steel | Ductile Iron | Stainless Steel | Ductile Iron | Stainless Steel |
| 3/4, 1 (20, 25) | 4.00 (102) | 4.12 (105) | 2.12 (53,8) | 2.25 (57,2) | 6.19 (157) | 6.19 (157) | 10.38 (264) | 10.38 (264) | 1.69 (42,9) | 1.69 (42,9) |

Figure 3. Y695VR Series Dimensions

Construction

Refer to the Specifications section and to each referenced table; specify the desired selection

whenever there is a choice to be made. Always be sure to specify the type number and the spring case connection location from Figure 3.

Industrial Regulators

Emerson Process Management Regulator Technologies, Inc.

USA - Headquarters
McKinney, Texas 75069-1872 USA
Tel: 1-800-558-5853
Outside U.S. 1-972-548-3574

Asia-Pacific
Shanghai, China 201206
Tel: +86 21 2892 9000

Europe
Bologna, Italy 40013
Tel: +39 051 4190611

Middle East and Africa
Dubai, United Arab Emirates
Tel: +971 4811 8100

Natural Gas Technologies

Emerson Process Management Regulator Technologies, Inc.

USA - Headquarters
McKinney, Texas 75069-1872 USA
Tel: 1-800-558-5853
Outside U.S. 1-972-548-3574

Asia-Pacific
Singapore, Singapore 128461
Tel: +65 6777 8211

Europe
Bologna, Italy 40013
Tel: +39 051 4190611
Gallardon, France 28320
Tel: +33 (0)2 37 33 47 00

TESCOM

Emerson Process Management Tescocom Corporation

USA - Headquarters
Elk River, Minnesota 55330-2445 USA
Tel: 1-763-241-3238

Europe
Selmsdorf, Germany 23923
Tel: +49 (0) 38823 31 0

For further information visit www.emersonprocess.com/regulators

The Emerson logo is a trademark and service mark of Emerson Electric Co. All other marks are the property of their prospective owners. Fisher is a mark owned by Fisher Controls, Inc., a business of Emerson Process Management.

The contents of this publication are presented for informational purposes only, and while every effort has been made to ensure their accuracy, they are not to be construed as warranties or guarantees, express or implied, regarding the products or services described herein or their use or applicability. We reserve the right to modify or improve the designs or specifications of such products at any time without notice.

Emerson Process Management does not assume responsibility for the selection, use or maintenance of any product. Responsibility for proper selection, use and maintenance of any Emerson Process Management product remains solely with the purchaser.